



XPS-EDBL

XPS Compatible External High-Performance Driver for Linear and Brushless Motors



 **Newport**[®]

User's Manual

Warranty

Newport Corporation warrants that this product will be free from defects in material and workmanship and will comply with Newport's published specifications at the time of sale for a period of one year from date of shipment. If found to be defective during the warranty period, the product will either be repaired or replaced at Newport's option. To exercise this warranty, write or call your local Newport office or representative, or contact Newport headquarters in Irvine, California. You will be given prompt assistance and return instructions. Send the product, freight prepaid, to the indicated service facility. Repairs will be made and the instrument returned freight prepaid. Repaired products are warranted for the remainder of the original warranty period or 90 days, whichever comes first.

Newport reserves the right to change the content and product specification without notice.

NEWPORT MAKES NO WARRANTY OR REPRESENTATION, EXPRESS OR IMPLIED, REGARDING NON-INFRINGEMENT, MERCHANTABILITY, OR FITNESS FOR PARTICULAR PURPOSE OF THE PRODUCTS. ANY BUYER OR USER ACKNOWLEDGES THAT THE BUYER OR USER ALONE HAS DETERMINED THAT THE PRODUCTS WILL SUITABLY MEET THE REQUIREMENTS OF THEIR INTENDED USE. NEWPORT DISCLAIMS ALL OTHER WARRANTIES, EXPRESS OR IMPLIED.

Limitation of Warranty

The above warranties do not apply to products which have been repaired or modified without Newport's written approval, or products subjected to unusual physical, thermal or electrical stress, improper installation, misuse, abuse, accident or negligence in use, storage, transportation or handling. This warranty also does not apply to fuses.

©2020 by Newport Corporation, Irvine, CA. All rights reserved.

Original instructions.

No part of this document may be reproduced or copied without the prior written approval of Newport Corporation. This document is provided for information only, and product specifications are subject to change without notice. Any change will be reflected in future publishings.

Table of Contents

Warranty	ii
Table of Contents	iii
UE Declaration of Conformity	v
Preface	vi
Scope of the Manual	viii
Definitions and Symbols	x
Safety Information	xi
Warnings & Cautions	xv
Application Considerations	xix
Disclaimers	xx
<hr/>	
1.0 Introduction	1
1.1 Description of Product and Features	1
1.2 System Configuration	2
1.3 Block Diagram	4
<hr/>	
2.0 Specifications	5
2.1 General Specifications	5
2.1.1 Product Identification	5
2.1.2 Technical Specifications	6
2.2 Cable Specifications	8
<hr/>	
3.0 Setting Up and Getting Started	9
3.1 Installation and Wiring Precautions	9
3.2 Installation conditions	10
3.2.1 Space Around Drivers for Air Flow	11
3.2.2 Mounting Direction	11
3.2.3 Operating Environment	11
3.2.4 Ambient Temperature	12
3.2.5 System Design and Installation	12
3.2.6 Keep Foreign Objects Out of Units	12
3.3 Wiring and Installing Drivers Card	13
3.3.1 Peripheral Device Connection Examples	13
3.3.2 Power Plug	15
3.3.3 Wiring Earth-Ground	15
3.3.4 Earth Grounding Paths	15
3.3.5 Installing the XPS-EDBL for Use with an XPS Controller	16
3.4 Connection XPS- EDBL	17

3.5	Configuration.....	18
3.6	Regenerative Energy Absorption.....	19
3.7	Running Performance Adjustments	22
<hr/>		
4.0	Troubleshooting.....	23
4.1	Preventative Measures	23
4.2	Troubleshooting by Means of Operating Status	23
4.3	Overload	23
4.4	Maintenance	24
<hr/>		
	Service Form	29

UE Declaration of Conformity

XPS-EDBL



Year **CE** mark affixed: 2017

EU Declaration of Conformity

The manufacturer:

MICRO-CONTROLE Spectra-Physics,
9 rue du Bois Sauvage
F-91055 Evry FRANCE

Hereby declares that the product:

- Description: "XPS-EDBL"
- Function: XPS Compatible External, High-Performance Driver for linear and brushless motors
- Type of equipment: Electrical equipment for measurement, control and laboratory

- complies with all the relevant provisions of the Directive 2014/30/EU relating to electromagnetic compatibility (EMC).
- complies with all the relevant provisions of the Directive 2014/35/EU relating to electrical equipment designed for use within certain voltage limits (Low Voltage)
- complies with all the relevant provisions of the Directive 2011/65/EU relating to RoHS2.

- was designed and built in accordance with the following harmonised standards:
 - NF EN 61326-1:2013 « Electrical equipment for measurement, control and laboratory use – EMC requirements – Part 1: General requirements »
 - NF EN 55011:2010/A1:2011 Class A
 - CEI 61010-1:2010 « Safety requirements for electrical equipment for measurement, control and laboratory use – Part 1: General requirements »

- was designed and built in accordance with the following other standards:
 - NF EN 61000-4-2
 - NF EN 61000-4-3
 - NF EN 61000-4-4
 - NF EN 61000-4-5
 - NF EN 61000-4-6
 - NF EN 61000-4-11

Date : 16/05/2017

Hervé LE COINTE
Quality Director

*MICRO-CONTROLE Spectra-Physics
Zone Industrielle
F-45340 Beaune La Rolande, France*

DC2-EN rev:A

Preface

Confidentiality & Proprietary Rights

Reservation of Title

Newport Programs and all materials furnished or produced in connection with them (“Related Materials”) contain trade secrets of Newport and are for use only in the manner expressly permitted. Newport claims and reserves all rights and benefits afforded under law in the Programs provided by Newport Corporation.

Newport shall retain full ownership of Intellectual Property Rights in and to all development, process, align or assembly technologies developed and other derivative work that may be developed by Newport. Customer shall not challenge, or cause any third party to challenge the rights of Newport.

Preservation of Secrecy and Confidentiality and Restrictions to Access

Customer shall protect the Newport Programs and Related Materials as trade secrets of Newport, and shall devote its best efforts to ensure that all its personnel protect the Newport Programs as trade secrets of Newport Corporation. Customer shall not at any time disclose Newport's trade secrets to any other person, firm, organization, or employee that does not need (consistent with Customer's right of use hereunder) to obtain access to the Newport Programs and Related Materials. These restrictions shall not apply to information (1) generally known to the public or obtainable from public sources; (2) readily apparent from the keyboard operations, visual display, or output reports of the Programs; (3) previously in the possession of Customer or subsequently developed or acquired without reliance on the Newport Programs; or (4) approved by Newport for release without restriction.

Sales, Tech Support & Service

North America & Asia

Newport Corporation
1791 Deere Ave.
Irvine, CA 92606, USA

Sales

Tel.: (800) 222-6440
e-mail: sales@newport.com

Technical Support

Tel.: (800) 222-6440
e-mail: tech@newport.com

Service, RMAs & Returns

Tel.: (800) 222-6440
e-mail: service@newport.com

Europe

MICRO-CONTROLE Spectra-Physics S.A.S
9 rue du bois sauvage
91055 Évry CEDEX
France

Sales France

Tel.: +33 (0)1.60.91.68.68
e-mail: france@newport.com

Sales Germany

Tel.: +49 (0) 61 51 /708 – 0
e-mail: germany@newport.com

Sales UK

Tel.: +44 (0)1635.521757
e-mail: uk@newport.com

Technical Support

e-mail: tech_europe@newport.com

Service & Returns

Tel.: +33 (0)2.38.40.51.55

Service Information

The user should not attempt any maintenance or service of the XPS-EDBL system beyond the procedures outlined in this manual. Any problem that cannot be resolved should be referred to Newport Corporation. When calling Newport regarding a problem, please provide the Tech Support representative with the following information:

- Your contact information.
- System serial number or original order number.
- Description of problem.
- Environment in which the system is used.
- State of the system before the problem.
- Frequency and repeatability of problem.
- Can the product continue to operate with this problem?
- Can you identify anything that may have caused the problem?

Newport Corporation RMA Procedures

Any XPS-EDBL being returned to Newport must have an assigned RMA number by Newport. Assignment of the RMA requires the unit's serial number.

Packaging

XPS-EDBL being returned under an RMA must be properly packaged for shipment. If possible, reuse the original factory packaging.

Scope of the Manual

Thank you for choosing the XPS-EDBL driver. Proper use and handling of the XPS-EDBL will ensure specified product performance, will lengthen product life, and may prevent possible accidents.

Please read this manual thoroughly, handle and operate the XPS-EDBL with care.

- To ensure safe and proper use of your Newport XPS-EDBL, please read this manual to gain sufficient knowledge of the product, safety information, and precautions before actual use.
- Copies of this manual and other related manuals must be delivered to the actual end users of the product.
- Please keep a copy of this manual close at hand for future reference.
- If an XPS-EDBL has been left unused for a long time, please consult with your Newport sales representative.

Notice

1. This manual describes the functions of the XPS-EDBL and its relationship with other products. Anything not described in this manual is beyond the scope of the product.
2. Although care has been given in generating this manual, please contact your Newport representative if you have any suggestions on improving this manual.
3. The XPS-EDBL operates with dangerous high voltages. Turn the power OFF and wait for at least five minutes to allow power to discharge before handling or working with the product. Never attempt to disassemble the XPS-EDBL.
4. We recommend that you add the following precautions to any instruction manual you prepare for the motion system into which the product is being installed.
 - Precautions on the dangers of high-voltage equipment.
 - Precautions on touching the terminals of the product even after power has been turned OFF. (These terminals are live even with the power turned OFF.)
5. Specifications and functions may be changed without notice in order to improve product performance.
6. Do not perform withstand-voltage or other mega meter tests on the product. Doing so may damage internal components.
7. The XPS-EDBL has a finite service life. Be sure to keep replacement products on hand and to consider the operating environment and other conditions affecting the service life

Upon Receipt of the Order

- Check that the packaging is not damaged.
- If there are visible signs of damage to the packaging, immediately notify the carrier and report the damage.
- Take pictures to illustrate the damage and keep for your records.
- Contact Newport if you suspect that the product could be damaged.



Items to Check After Unpacking

Check the following items after removing the product from the package:

- Has the correct product been delivered (i.e., the correct model number and specifications) and complete?
- If there were visible signs of damage to the packaging, inspect the product in detail for damage. Note the damages and take pictures as needed.
- Inspect the enclosure for any loose screws or bolts.



WARNING

Do not operate the product if there are signs of damage to the enclosure, loose components, etc.

Definitions and Symbols

Newport products are manufactured for use according to proper procedures by a qualified operator and only for the purposes described in this manual.

The following conventions are used to indicate and classify precautions in this manual. Always heed the information provided with them. Failure to heed precautions can result in injury to people or damage to property.



DANGER

Indicates an imminent or a potentially hazardous situation which, if not avoided/corrected, will result in death or serious injury. Additionally, there may be severe property damage.



WARNING

Indicates a potentially hazardous situation which, if not avoided, could result in death or serious injury. Additionally, there may be severe property damage.



CAUTION

Indicates a potentially hazardous situation which, if not avoided, may result in minor or moderate injury, or property damage.

Safety Information

Requirements

IMPORTANT

Please read this information **BEFORE** installing the equipment.

Intended Users

This manual is to be made available to all persons who are required to install, configure or service equipment described herein, or any other associated operation.

The information given is intended to highlight safety issues, EMC considerations, and to enable the user to obtain the maximum benefit from the equipment.

Complete the following table for future reference detailing how the unit is to be installed and used.

INSTALLATION DETAILS	
Serial Number (see product label)	
Where installed (for your own information)	
Unit used as a: (refer to Certification for the Inverter)	<input type="checkbox"/> Component <input type="checkbox"/> Relevant Apparatus
Unit mounting	<input type="checkbox"/> Conform additional Enclosure

Limit of Application

The XPS-EDBL equipment described in this manual is intended for industrial motor current control of AC induction or AC synchronous machines.

Personnel

Installation, operation and maintenance of the equipment should be carried out by qualified personnel. A qualified person is someone who is technically competent and familiar with all safety information and established safety practices; familiar with the installation process, operation and maintenance of this equipment; and familiar with all the hazards involved.

Product Warnings



Caution
Risk of electric shock



Caution
Refer to documentation



Earth/Ground
Protective Conductor Terminal



CE Marking
The main indicator of a product that conforms to EU legislation and enables the free movement within the European market.



Disposal
Dispose of the product at the end of its life span in accordance with legal regulations.



Direction of the Air Flow
The opening on the driver's sides should not be blocked to allow air to flow in this direction.

EOR

Connector for the signal corresponding to End of Runs.

Command

Connector for the command signals coming/going from/to the XPS controller.

Motor

Connector for the motor and the motor's thermistor terminals.

Hazards



DANGERS

Ignoring the following may result in injury.

1. This equipment can endanger life, due to exposure to high voltages, and when connected to high speed, rotating or reciprocating machinery.
2. The equipment must be permanently earthed (grounded) due to the high earth leakage current, and the drive motor must be connected to an appropriate safety earth.
3. The equipment should be permanently connected to an installation which incorporates the recommended protection devices.
4. Ensure all incoming power supplies are isolated before working on the equipment. Be aware that there may be more than one power supply connection to the motor drive.
5. There may still be dangerously high voltage present at the power terminals (motor output, supply input phases, DC bus and the brake, where fitted) when the motor is at standstill or is stopped.
6. When making measurements, use only an electrical meter rated to IEC 61010 (CAT III or higher). Always begin using the highest range. CAT I and CAT II meters must not be used on this product.
7. Allow at least 5 minutes for the motor drive's capacitors to discharge to safe voltage levels (<50V). Use the specified meter capable of measuring up to 1000V DC & ACrms to confirm that less than 50V is present between all power terminals and earth (ground).
8. Unless otherwise stated, this product must NOT be dismantled or disassembled. In the event of a defective unit, the drive must be returned for repair.
9. In case of an error condition reported by the amplifier, power off the unit, remove the error condition and power back the unit.



WARNING

Ignoring the following may result in injury or damage to equipment.

Safety

Where there is conflict between EMC and Safety requirements, personnel safety shall always take precedence.

- If the product is not used in the condition specified, the safety can be compromised.
- Never perform high voltage resistance checks on the wiring without first disconnecting the motor drive from the circuit being tested.
- While ensuring ventilation is sufficient, provide guarding and /or additional safety systems to prevent injury or damage to equipment.
- When replacing a motor drive in an application and before returning it to use, it is essential that all user-defined parameters for the product's operation are correctly installed.
- This equipment contains electrostatic discharge (ESD) sensitive parts. Observe static control precautions when handling, installing and servicing this product.
- Ensure all external wiring is rated for the highest system voltage.
- Thermal sensors contained within the motor must have reinforced insulation.
- All exposed metalwork in the Inverter is protected by basic insulation and connected to a safety earth (ground).
- Refer to the installation requirements of your facility and local applicable Standards concerning the use of RCDs (residual current device).

EMC

This is a product in the restricted sales distribution class according to IEC 61800-3. It is designated as “professional equipment” as defined in EN61000-3-2. Written permission from Newport shall be obtained before connection to the low voltage supply.

Application Risk

The specifications, processes and circuitry described herein are for guidance only and may need to be adapted to the user’s specific application. Newport does not guarantee the suitability of the equipment described in this manual for individual applications.

The safety of the system in which this product is integrated is the responsibility of the assembler.

Risk Assessment

Under fault conditions, power loss or unintended operating conditions, the drive may not operate as expected. In particular:

- Stored energy might not discharge to safe levels as quickly as expected, and can still be present even though the drive appears to be switched off.
- The motor's direction of rotation might not be controlled.
- The motor speed might not be controlled.
- The motor might still be energized.

A motor drive is a component within a drive system that may influence its operation or effects under a fault condition. Consideration must be given to:

- Stored energy.
- Supply disconnects.
- Sequencing logic.
- Unintended operation.

Warnings & Cautions

General Warnings

Observe the following warnings and cautions when connecting the XPS-EDBL to AC induction or AC synchronous machines.

Consult your Newport representative when using the product after a long period of storage.

WARNING

Always connect the frame ground terminals of the XPS-EDBL to a ground ($\leq 0.1 \Omega$). Not doing so may result in electric shock.

WARNING

Never touch the inside of the XPS-EDBL. Doing so may result in electric shock.

WARNING

Never remove the cover, terminal covers, cables, or optional items while the power is being supplied. Doing so may result in electric shock.



WARNING

Installation, operation, cleaning, or inspection must be performed by qualified personnel. Unqualified personnel may experience electric shock or get injured. Use appropriate lock-out/tag-out methods to ensure safety in service.

WARNING

Wiring or inspection must not be performed for at least five minutes after having removed the supply. Doing so may result in electric shock.

WARNING

Do not damage, press, or put excessive stress or heavy objects on the cables. Doing so may result in electric shock.

WARNING

Do not modify the product. Doing so may result in injury or damage to the product.

CAUTION

Use the XPS-EDBL in the specified condition only. Using it incorrectly may result in fire or damage to the products.

CAUTION

Do not store or install the product in the following places. Doing so may result in fire, electric shock, or damage to the product.



- Locations subject to direct sunlight.
 - Locations subject to temperatures or humidity outside the operating or storage ranges given in the specifications.
 - Locations subject to condensation as the result of severe changes in temperature.
 - Locations subject to corrosive or flammable gases.
 - Locations subject to dust (especially iron dust) or salts.
 - Locations subject to shock or vibration.
 - Locations subject to exposure to water, oil, or chemicals.
-

CAUTION

Do not touch the XPS-EDBL while the power is being supplied or soon after having removed the supply. Doing so may result in burns from hot surfaces.

Storage and Transportation Precautions

CAUTION

Do not hold the product by the cables or motor shaft while transporting it. Doing so may result in injury or malfunction.



CAUTION

Do not place any load exceeding the value indicated on the product. Doing so may result in injury or malfunction.

Installation and Wiring Precautions

CAUTION

Do not cover the inlet or outlet ports and prevent any foreign objects from entering the product. Not doing so may result in fire.

CAUTION

Be sure to install the product in the correct direction. Not doing so may result in malfunction.



CAUTION

Provide the specified clearances between the XPS-EDBL and other devices. Not doing so may result in fire or malfunction.

CAUTION

Do not apply any strong impact on the product. Not doing so may result in malfunction.

CAUTION

Be sure to wire correctly and securely. Not doing so may result in injury, or malfunction.

CAUTION

Be sure that all the mounting screws, terminal screws, and cable connector screws are tightened to the torque specified in the relevant manuals. Incorrect torque may result in malfunction.

CAUTION

Use crimp terminals for wiring. Do not connect bare stranded wires directly to terminals. Connection of bare stranded wires may result in burning.

CAUTION

Always use the power supply voltage specified in the User's Manual. An incorrect voltage may result in malfunction or burning.

CAUTION

Take appropriate measures to ensure that the specified power with the rated voltage and frequency is supplied. Be particularly careful in places where the power supply is unstable. An incorrect power supply may result in malfunction.



CAUTION

Install external breakers and take other safety measures against short-circuits in external wiring. Insufficient safety measures against short-circuits may result in burning.

CAUTION

Provide an appropriate stopping device on the machine side for safety. (A holding brake is not a stopping device for safety.) Not doing so may result in injury.

CAUTION

Provide an external emergency stop device that allows an instantaneous stop of operation and power interruption. Not doing so may result in injury.

CAUTION

Secure the area around the motion system with the appropriate signs or interlock methods. Not doing so may result in injury.

CAUTION

Power input wiring does not require shielding (screening) if the power is fed to the enclosure via metal conduit. If metal conduit is not used in the system, shielded cable is required on the power input wires.

CAUTION

Take appropriate and sufficient countermeasures when installing systems in the following locations:

- Locations subject to static electricity or other forms of noise.
 - Locations subject to strong electromagnetic fields and magnetic fields.
 - Locations subject to possible exposure to radioactivity.
 - Locations close to power supplies.
-

Operation and Adjustment Precautions

CAUTION

Confirm that no adverse effects will occur in the system before performing the test operations. Not doing so may result in equipment damage.

CAUTION

Check the newly set parameters for proper execution before actually running them. Not doing so may result in equipment damage.



CAUTION

Do not make any extreme adjustments or setting changes. Doing so may result in unstable operation and injury.

CAUTION

Separate the driver from other machines, check for proper operation, and then connect to other machines. Not doing so may cause injury.

CAUTION

Do not come close to the machine immediately after resetting momentary power interruption to avoid an unexpected restart. (Take appropriate measures to secure safety against an unexpected restart.) Doing so may result in injury.

Maintenance and Inspection Precautions

WARNING

Do not attempt to disassemble, repair, or modify any Units. Any attempt to do so may result in malfunction, fire, or electric shock.



CAUTION

Resume operation only after transferring to the new Unit the contents of the data required for operation. Not doing so may result in an unexpected operation.

Warning Labels

A warning label is attached to the product as shown in the following illustration. Be sure to follow the given instructions.



Application Considerations

Suitability for Use

Newport shall not be responsible for conformity with any standards, codes, or regulations that apply to the combination of products in the customer's application or use of this product.

At the customer's request, Newport will provide applicable third party certification documents identifying ratings and limitations of use that apply to this product. This information by itself is not sufficient for a complete determination of the suitability of the product in combination with the end product, machine, system, or other application or use.

The following are some examples of applications for which particular attention must be given. This is not intended to be an exhaustive list of all possible uses of the products, nor is it intended to imply that the listed uses may be suitable for this product:

- Outdoor use, uses involving potential chemical contamination or electrical interference, or conditions or uses not described in this manual.
- Nuclear energy control systems, combustion systems, railroad systems, aviation systems, medical equipment, amusement machines, vehicles, safety equipment, and installations subject to separate industry or government regulations.
- Systems, machines, and equipment that could present a risk to life or property. Please know and observe all prohibitions of use applicable to this product.

NEVER USE THE XPS-EDBL PRODUCT FOR AN APPLICATION INVOLVING SERIOUS RISK TO LIFE OR PROPERTY WITHOUT ENSURING THAT THE SYSTEM AS A WHOLE HAS BEEN DESIGNED TO ADDRESS THE RISKS, AND THAT THE NEWPORT PRODUCT IS PROPERLY RATED AND INSTALLED FOR THE INTENDED USE WITHIN THE OVERALL EQUIPMENT OR SYSTEM.

Programmable Products

Newport shall not be responsible for the user's programming of a programmable product, or any consequence thereof.

Disclaimers

Change in Specifications

Product specifications and accessories may be changed at any time based on improvements and other reasons.

Specifications of the products may be changed without any notice. When in doubt, special model numbers may be assigned to fix or establish key specifications for your application on your request. Please consult with your Newport representative at any time to confirm actual specifications of purchased products.

Dimensions and Weights

Dimensions and weights are nominal and are not to be used for manufacturing purposes, even when tolerances are shown.

Performance Data

Performance data given in this manual is provided as a guide for the user in determining suitability and does not constitute a warranty. It may represent the result of Newport's test conditions, and the users must correlate it to actual application requirements. Actual performance is subject to Newport's Warranty and Limitations of Liability.

Errors and Omissions

The information in this manual has been carefully checked and is believed to be accurate; however, no responsibility is assumed for clerical, typographical, or proofreading errors, or omissions.



XPS Compatible External High-Performance Driver for Linear and Brushless Motors

XPS-EDBL

1.0 Introduction

1.1 Description of Product and Features

The XPS-EDBL is a high-power, 3-phase, sinusoidal motor driver (amplifier). It features 25A peak current and +96V DC bus voltage, up to 1,000 watts of permanent power when optional fans are mounted.

The power stage is fully featured and protected. It incorporates AC/DC converters to generate the internal high voltage and the DC supplies for the logic, efficient MOSFETS for the 3-phase inverter output, and a 150W power resistor to dissipate regeneration energy. Two optional fans further limit the temperature increase of the driver (amplifier).

The driver (amplifier) controls the current in the 3 phases of the motor which, by convention, will be called U, V and W. The command from an external controller consists of two analog sinusoidal signals with a 120° phase difference and a +/-10V amplitude which set the U and V current targets for the motor. The W is internally generated by the driver itself (amplifier).

The current control loop is a digital PI, configurable over the I2C communication interface, which has a high-resolution of 16bits on command and current measurements.

Once the driver (amplifier) is configured with the appropriate settings to the motor characteristics and the required bandwidth, the TTL signal is used to enable the driver (amplifier).

An open collector output reports a fault condition after the shutdown of the driver in case an error is detected. Status of the driver is read on the I2C and gives the error code(e.g. current limit, RMS current limit, thermistor fault...).

The XPS-EDBL is intended for use in an Industrial Environment, it should be mounted within an enclosure which provides protection to the Driver and the user. The Driver should be permanently earthed (grounded) at the terminals provided.

Conformity to Standards

The XPS-EDBL conforms to EC Directives (both low-voltage and EMC) and is built of UL listed components, thereby assisting the user in meeting required standards.

Built-in Regenerative Power Processing

In addition to the built-in regenerative power processing function using regeneration resistance, external regeneration resistance can also be connected on demand (contact Newport), allowing the XPS-EDBL to be used for applications with high regenerative energy requirements like those for a vertical axis.

Online Auto-tuning

XPS-EDBL auto-tuning is possible during normal operation, without the need to switch to a special auto-tuning mode.

Parameter Initialization

Parameters are provided by the controller through the I2C bus.

Current Control is handled through analog controls.

1.2 System Configuration

Below is a diagram that explains how an XPS-EDBL is intended to be used:

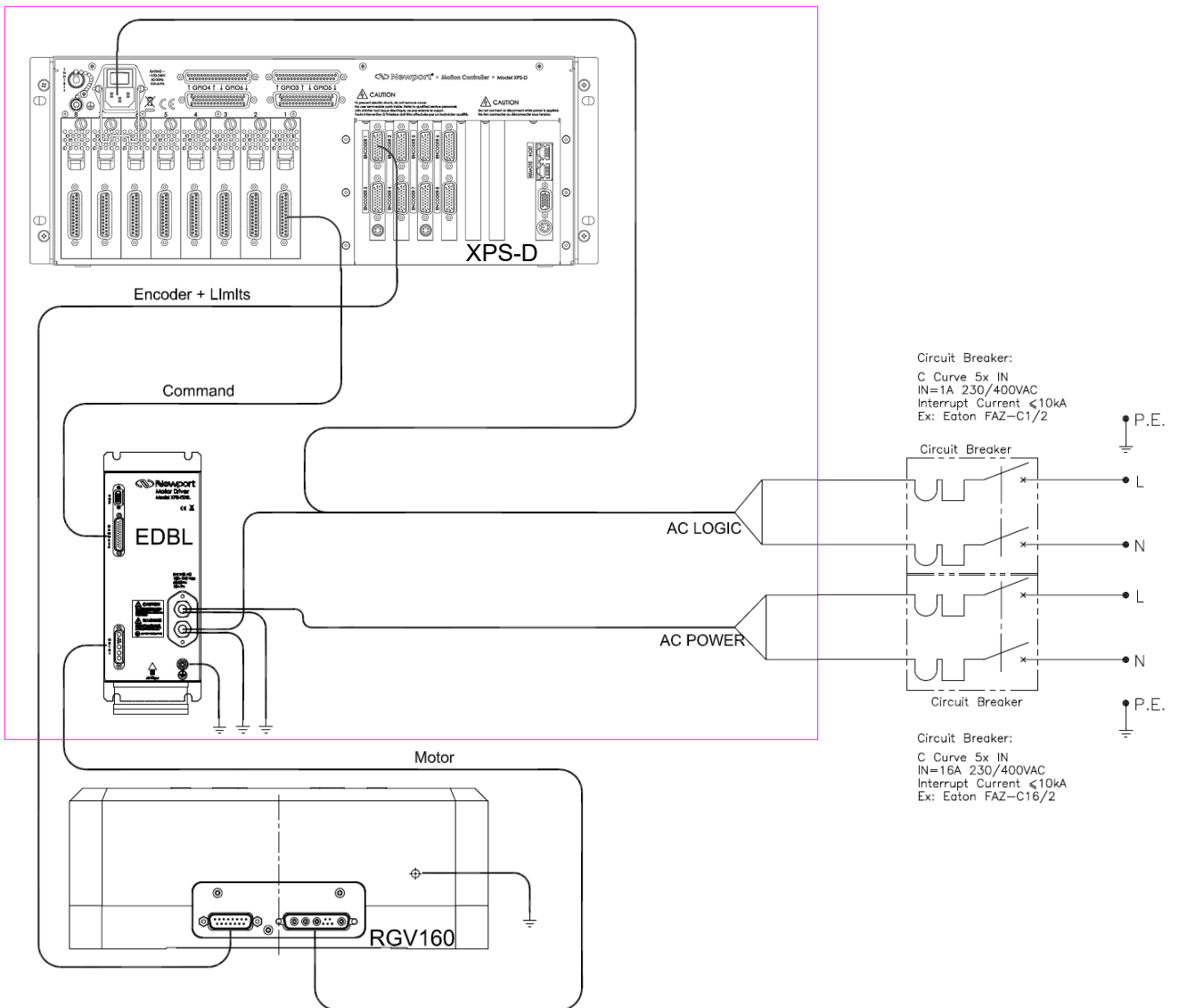

The COMMAND cable length is 1 meter.

The AC POWER cable length is 1.5 meter. It has 2 stickers: “POWER” and “E5084x” and the marking 3G1.5 mm².

The AC LOGIC cable length is 1.5 meter. It has 2 stickers: “LOGIC” and “E5084x” and the marking 3G0.75 mm².

Do not remove the stickers when installing the driver permanently.

The power switch used in the installation should have a marking that it is the main power-cutting element of the installation and should be placed near the equipment.

When cutting power, AC POWER should be switched off first, and then AC LOGIC.

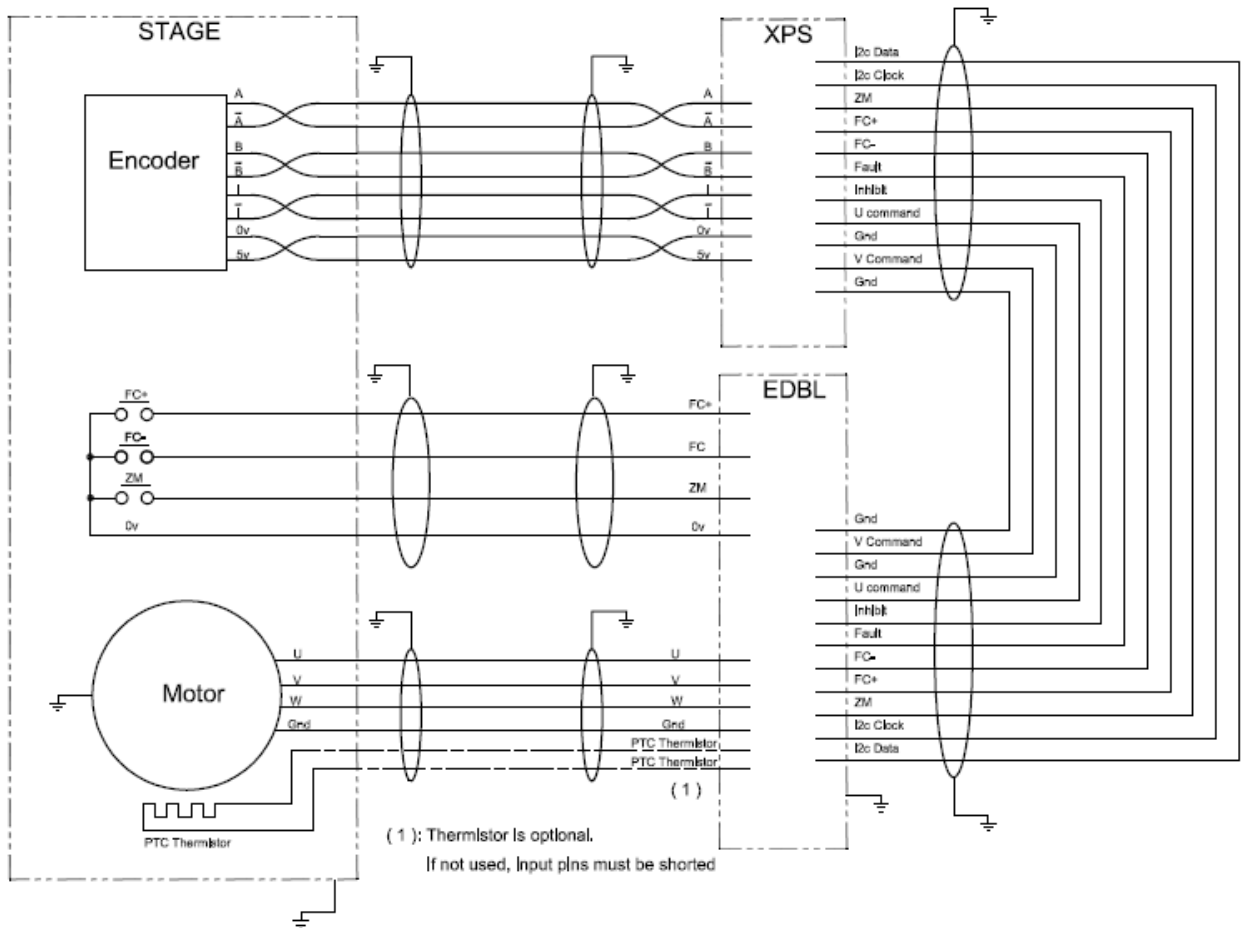

Figure 1-1: Diagram showing the connections to the XPS-EDBL

NOTE

All connector shells are connected to PE (protective earth).

The driver (amplifier) is intended to be used only with the XPS controller, which sends the configuration via an I2C communication, generates the appropriate U&V commands, and manages the fault conditions.

Initialization of the motor position is to be done by the external controller using external position sensors.

End of run signals are not used inside the EDBL. They only pass through to the controller.

NOTE

**System configuration for third party motors:
Contact Newport Technical Support for assistance.**

1.3 Block Diagram

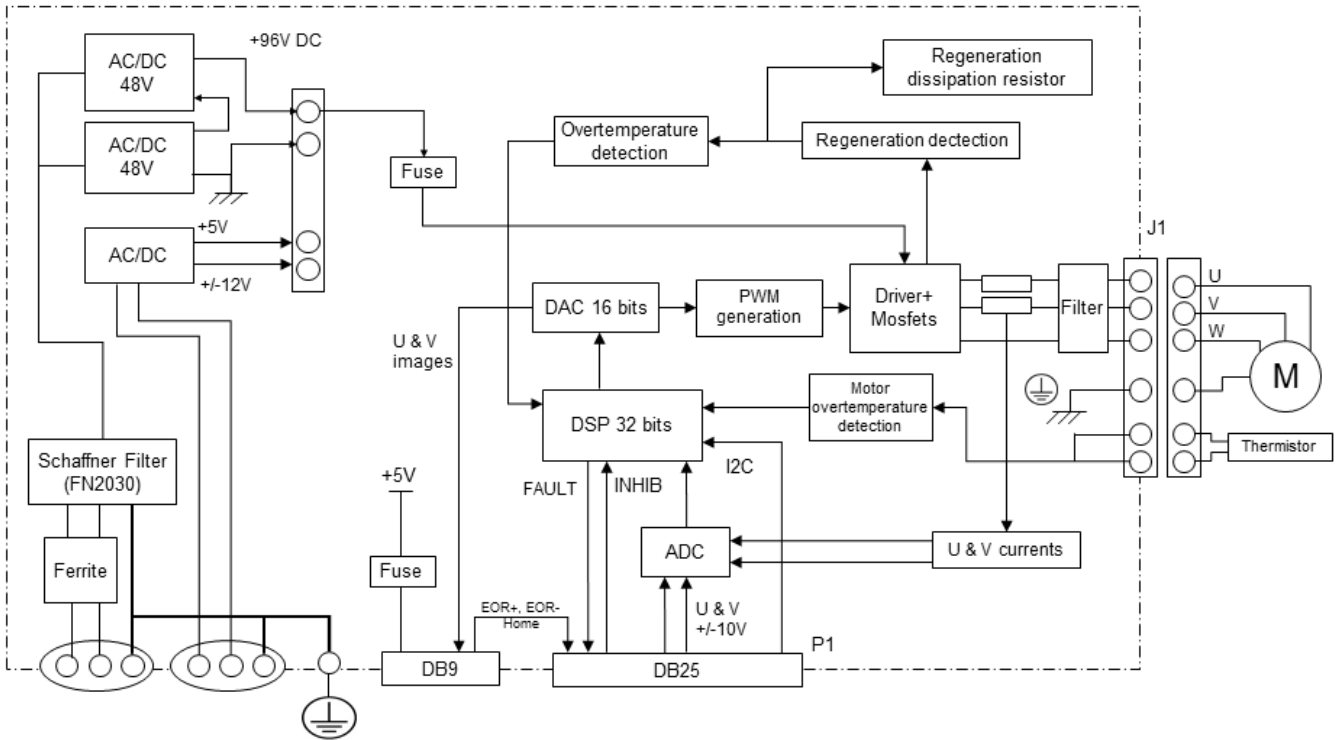

Figure 1-2: diagram XPS-EDBL

- The FAULT signal is an open collector output to signal a problem on the driver.
- The INHIB signal is used to enable the driver (amplifier).
- The dynamic break signal is used to short circuit the motor to ground.

2.0 Specifications

2.1 General Specifications

2.1.1 Product Identification

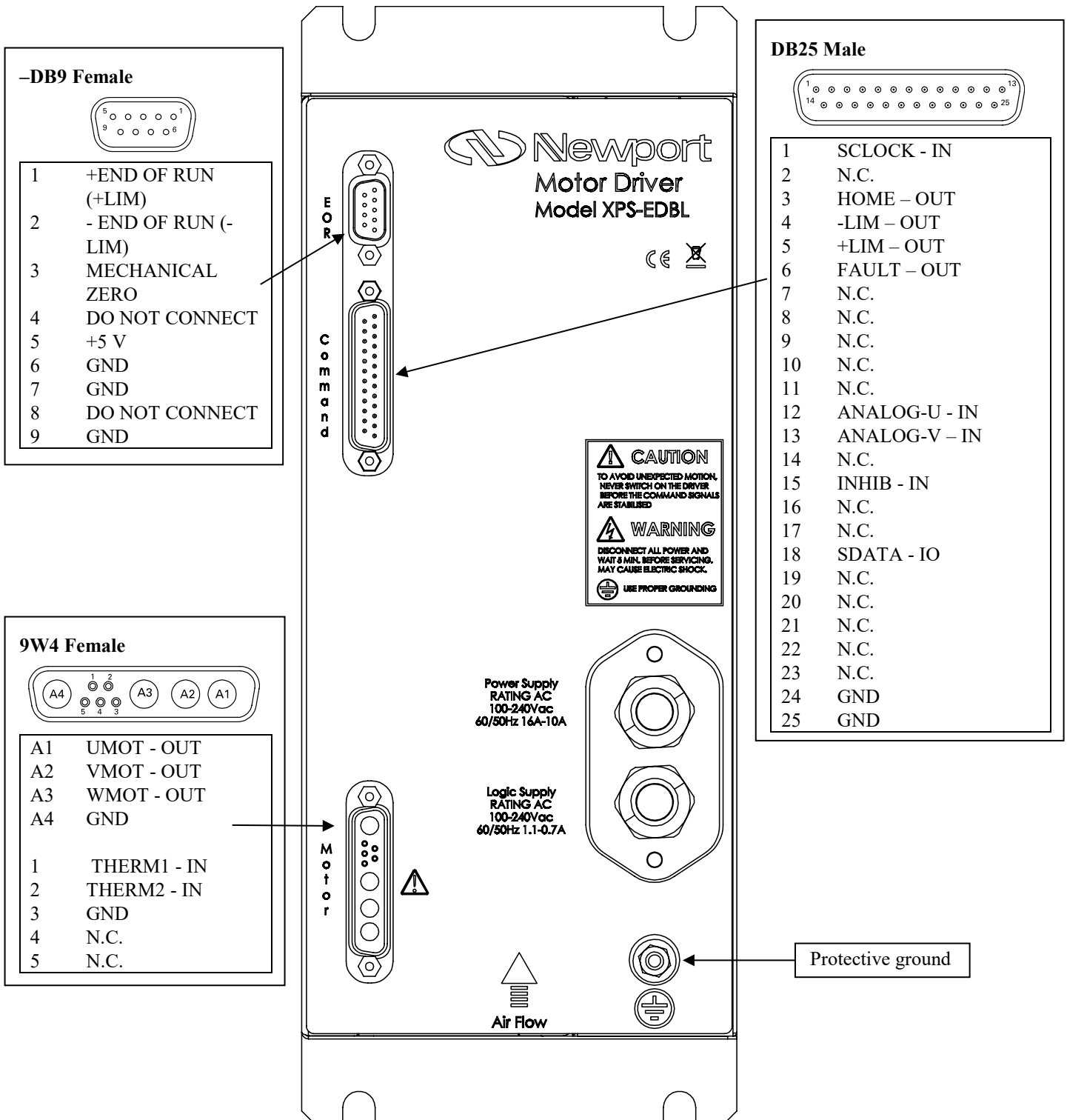

2.1.2 Technical Specifications

General

Number of Axes	1 axis, DC brushless motors driver.		
Communication Interfaces	<ul style="list-style-type: none"> •Analog, I2C, TTL. •Interface to XPS via XPS-DRV00P interface board. 		
Analog Inputs (commands)	Commanded U&V phases currents	±10 V Resolution 16 bits	-
Digital Inputs	INHIB, when this input is low the amplifier current outputs are enabled.	+3.3 V, 2.21K pull up TVS 3.3V PESD52 3.3	-
	SCLOCK	+5 V, 10 k pull up	-
	SDATA	+5 V, 10 k pull up	-
Digital Outputs	FAULT, when high indicates a problem on the amplifier. Refer to the hardware protective functions for more details. When the amplifier is enabled the non fatal errors should be cleared and the fault signal should go low.	Open collector (+50V max)	20 mA sink
Pass Through signal	P2-6 ----> P1-5 P2-7 ----> P1-4 P2-8 ----> P1-3		
Derating Power output	Derate linearly from 100V down to 80% at 90V		
PWM frequency	100 kHz ±20%		
Output filter	17 kHz		
Inrush current	200 A/230 VAC – 100 A/115 VAC		
Supply Voltage	100 VAC - 240 VAC		
Supply Current (max permanent state)	5 A/10 A (240 V/100 V) with fans 2.5 A/5 A (240 V/100 V) without fans		
Supply Frequency	50/60 Hz		
Overvoltage category	II		
Current Control Action	Closed Loop with Proportional Integral Control		
Frequency	100 to 2,000 Hz with limit of the electrical time constant of the motor ($T_e = L/R$).		
Frequency characteristics	The PI coefficients are calculated from the resistance, inductance and target cut off frequency. The real resulting frequency characteristics (i.e. transfer function of the driver) depends on the tolerances of the theoretical values of resistances and inductances.		
Peak Current Limit	25 A peak per phase		
Permanent power Limit	1 kW with fans 576 W without fans		
Motor protection thermistor	Detection PTC max = 9 kΩ, threshold variable (500 Ω to 8500 Ω)		
Internal regeneration resistor	150 W - 150 Ω		
Motor winding resistance	0.1 to 20 Ω. At low values of R and L, tolerances on theoretical values are critical. Therefore, in situ measurements are required to guarantee accurate transfer function of the driver.		
Motor winding inductance	0.1 to 40 mH. At low values of R and L, tolerances on theoretical values are critical. Therefore, in situ measurements are required to guarantee accurate transfer function of the driver.		
XPS-EDBL Enclosure	Chassis vertical Mounting IP00 (UL open-type)		
Additional Enclosure		IP50 minimum and IK08 minimum. Fire resistant to level V1 minimum. The sign “Risk of electrical shock” should be added on a visible spot of the additional enclosure.	
Operating Temperature	0 to +40 °C (Derate 1.5%/Degree above 40 °C)		
Humidity	85% R.H. at 40 °C (Non-condensing)		

Altitude	Above 1000 m derate at 1% / 100 m, max. 2000 m
Storage Temperature	-25 °C to +55 °C (Non-condensing)
Pollution	Pollution Degree 2, exempt of conducting dust.
Transport Temperature	-25 °C to +70 °C (Non-condensing)
Overall Width	120.65 mm (4" ¾)
Overall Height	262.00 mm (10" ½ or 6U)
Overall Depth	305.30 mm (12")
Weight	6.7 kg (without mounting plate)

Protective functions	
Error detection function	Contents
Over current	Short circuit
Over power	Version without optional fans
Fuse 12 A (with fans) Fuse 6 A (without fans)	Internal fuse broken, contact Newport
Fuse 1 A	EOR supply (both end of runs activated)
Motor over temperature	Thermistors fault
Driver over temperature	Error flag set when the temperature on the heatsink inside the driver reaches a limit of 70 °C Same error flag as 'Thermistors fault'
Initialization error	Invalid parameters
Current RMS	I2T
Current regulation error	Same error flag as 'Current RMS'

NOTE

The PI Corrector is calculated from the Resistor, Inductor and Frequency parameters.

$$Kp = 2 \times \Pi \times Freq \times Lmot$$

$$Ki = 2 \times \Pi \times Freq \times Rmot$$

EMC Technical Ratings

NOTE

The specified EMC emission and immunity performance of this unit can only be achieved when the unit is installed to the EMC installation instructions given in this manual.

IMPORTANT

Before installation, clearly understand who is responsible for conformance with the EMC directive.

Basic and Generic Standards:

The standards that may apply to this unit come under two broad categories:

1. **Emission:** These standards limit the interference caused by operating this drive module.
2. **Immunity:** These standards limit the effect of interference on this unit from other electrical and electronic apparatus.

Phenomenon	Test standard
Radiated Emission	NF EN 55011
Conducted on AC mains ports Emission	EN NF 55011
Electrostatic discharges immunity	NF EN 61000-4-2
Immunity to radio frequency electromagnetic field	NF EN 61000-4-3
Fast transient/burst immunity on AC mains ports	NF EN 61000-4-4
Fast transient/burst immunity on input-output cables	NF EN 61000-4-4
Surge immunity on AC mains ports	NF EN 61000-4-5
Immunity to conducted disturbances induced by radio frequency fields on AC mains ports	NF EN 61000-4-6
Immunity to conducted disturbances induced by radio frequency fields on input-output cables	NF EN 61000-4-6
Voltage dips, short interruptions and voltage variation immunity	NF EN 61000-4-11

2.2 Cable Specifications

For permanent installation, the cable should be cut near the connector and should be permanently connected to an installation which includes all required safety components (fuses, interruptors..).

All wires, including protective earth, should be securely fastened.

AWG size	Resistance Copper	Metric size (mm ²)
	mΩ/m	
20	33.292	0.5
18	20.942	0.8
16	13.172	1.0
14	8,28	2.0
12	5,21	3.0
10	3,28	5.0
8	2,06	8.0
7	1.634	10.0
6	1.295	13.0

The Ampacity of the cables must be in accordance with the motor power specification.

- Temperature rise of cables, motor depends on the type of wire used.
- Section of cables used must be adequate with the sections of the supply conductors
- It's recommended to use a cable 14AWG minimum for 5m and a cable of 10 mm² minimum for ground.

3.0 Setting Up and Getting Started

3.1 Installation and Wiring Precautions

CAUTION

Do not step on or place a heavy object on the XPS-EDBL. Doing so may result in injury.

CAUTION

The EDBL is a 7 kg equipment which is intended for static use and therefore does not have handles, it can cause injuries during the manipulation. It's recommended that the operator wear adequate protecting gloves and safety shoes when transporting and installing the EDBL.

CAUTION

Do not cover the inlet or outlet ports and prevent any foreign objects from entering the product. Failure to observe this may result in fire.

CAUTION

Be sure to install the XPS-EDBL in the correct direction. Not doing so may result in malfunction.

CAUTION

The XPS-EDBL must be mounted in an enclosure, and the enclosure must bear the weight of XPS-EDBL.

CAUTION

Provide the specified clearances between the EDBL and other devices. Not doing so may result in fire or malfunction.



CAUTION

Do not hit or otherwise apply any strong impact to the XPS-EDBL. Doing so may result in malfunction.

CAUTION

Be sure to wire correctly and securely. Not doing so may result in motor runaway, injury, or malfunction.

CAUTION

Be sure that all the mounting screws, terminal screws, and cable connector screws are tightened to the torque specified in the relevant manuals. Incorrect tightening torque may result in malfunction.

CAUTION

Use crimp terminals for wiring. Do not connect bare stranded wires directly to terminals. Connection of bare stranded wires may result in burning.

CAUTION

Always use the power supply voltages specified in this manual. An incorrect voltage may result in malfunctioning or burning.

CAUTION

Take appropriate measures to ensure that the specified power with the rated voltage and frequency is supplied. Be particularly careful in places where the power supply is unstable. An incorrect power supply may result in malfunction.

CAUTION

It is strictly forbidden to access to motor connector and connectors data when the equipment is supplied

CAUTION

Install external breakers and take other safety measures against short-circuiting in external wiring. Insufficient safety measures against short-circuiting may result in burning.

CAUTION

Disconnect power before cleaning the Driver unit. Do not use liquid or aerosol cleaners.

CAUTION

All equipment to be connected to the product must have an enclosure having a minimum fire resistance of V-1.



CAUTION

The EDBL is not equipped with internal overcurrent protection on power lines. Users should implement the required protections in their installation following the recommendations given in this manual.

CAUTION

To avoid damage to the product, take appropriate and sufficient countermeasures when installing systems in the following locations:

- Locations subject to static electricity or other sources of noise.
- Locations subject to strong electromagnetic fields and magnetic fields.
- Locations subject to possible exposure to radiation.
- Locations close to power supply lines.

CAUTION

The EDBL is delivered with power sockets to ease the preliminary tests after reception of the product. They should be cut and removed and the EDBL should be **PERMANENTLY CONNECTED** to an installation which includes the required switches, fuses and circuit breakers.

3.2 Installation conditions

The EDBL is delivered with an aluminum interface plate which can be used as the main support for rack mounting. This plate has:

- 4 threaded M4 Inserts 8mm deep on a rectangular pattern of 238 x 88.9 mm.
- 4 clearance holes for M4 screws on a rectangular pattern of 300 x 88.9 mm.

The EDBL must be mounted vertically inside an enclosure which guarantees a protection against electrical shock with a minimum of IP50 and IK08, and against fire propagation (V1 protection level minimum).

The EDBL and XPS should not have accessible parts after installation inside the additional enclosure.

The additional enclosure shall be made of metal (except magnesium) and shall have adequate rigidity.

3.2.1 Space Around Drivers for Air Flow

Case of single driver

You must leave a space between the driver and the environment where it is installed to allow air to flow freely (see figure3-1 space around drivers).

Case of multiple drivers

- Install XPS-EDBL Drivers according to the dimensions shown in the following illustration to ensure proper heat dissipation and convection inside the panel. Install fans for air circulation if the XPS-EDBL Drivers are installed side by side, to prevent uneven temperatures from developing inside the panel.
- Take the control cable's connector direction into account when installing the XPS-EDBL Drivers.

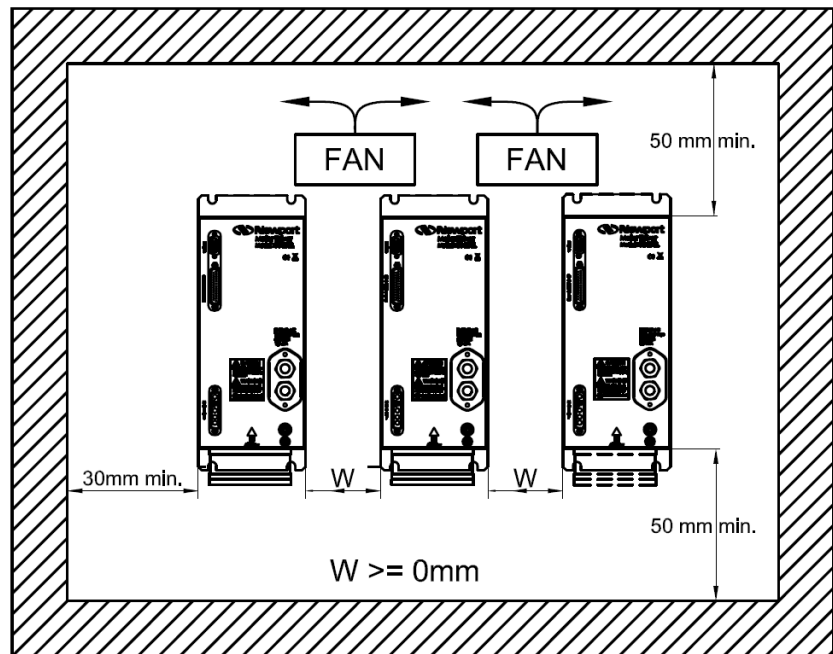

Figure 3-1: Space around Drivers.

3.2.2 Mounting Direction

Mount the XPS-EDBL Drivers in a direction (vertically) such that the air will flow through with fans or without fans by convection.

3.2.3 Operating Environment

The environment in which EDBL Drivers operate must meet the following conditions.

- Ambient operating temperature: 0 to +40 °C (Take into account the temperature rise in the individual EDBL Drivers).
- Ambient operating humidity: 20% to 85% (non-condensing).
- Atmosphere: No corrosive gases.

3.2.4 Ambient Temperature

- XPS-EDBL Drivers should be operated in a controlled environment where there is minimal temperature rise. This will ensure a high level of reliability.
- Temperature rise in any installed EDBL unit in a closed space, such as a control box, will cause the ambient temperature to rise inside the entire closed space. Use a fan or an air conditioner to prevent the ambient temperature of the XPS-EDBL Driver from exceeding 40° C.
- Unit surface temperatures may rise to as much as 30° C above the ambient temperature. Use heat resistant materials for wiring, and separate any devices or wiring that are sensitive to heat.

3.2.5 System Design and Installation

The service life of an XPS-EDBL Driver is largely determined by the temperature around the internal electrolytic capacitors. The service life of an electrolytic capacitor is affected by a drop in electrolytic volume and an increase in internal resistance, which can result in overvoltage alarms, malfunctioning due to noise, and damage to individual elements. If an XPS-EDBL Driver is always operated at the maximum ambient temperature of 40° C and at 80% of the rated Current, then a service life of approximately 50,000 hours can be expected. Drops of 10° C in the ambient temperature will double the expected service life.

3.2.6 Keep Foreign Objects Out of Units

- Place a cover over the XPS-EDBL units or take other preventive measures to prevent foreign objects, such as drill filings, from getting into the units during installation. Be sure to remove the cover after installation is complete. If the cover is left on during operation, heat buildup may damage the unit.
- Take measures during installation and operation to prevent foreign objects such as metal particles, oil, machining oil, dust, or water from getting inside of XPS-EDBL Drivers.

3.3 Wiring and Installing Drivers Card

3.3.1 Peripheral Device Connection Examples

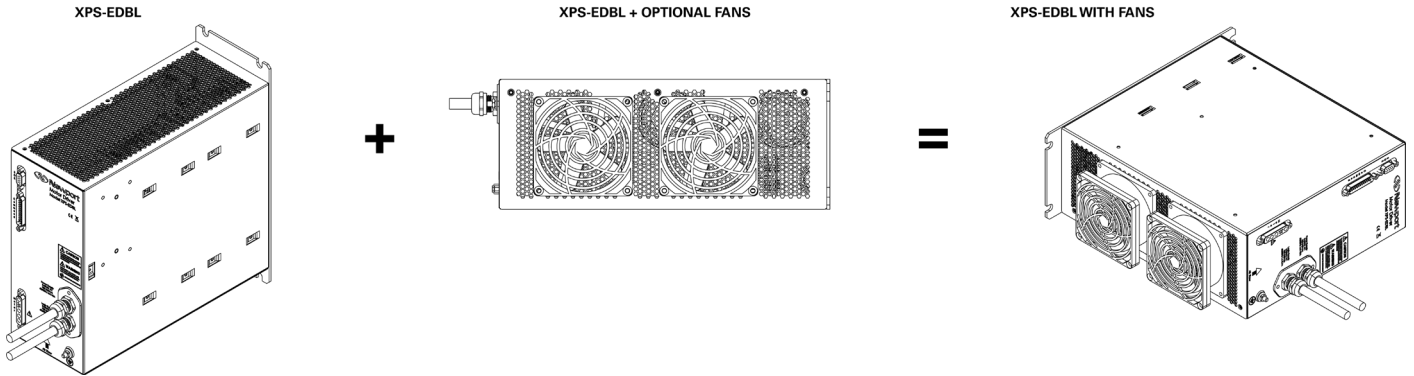

External dimensions

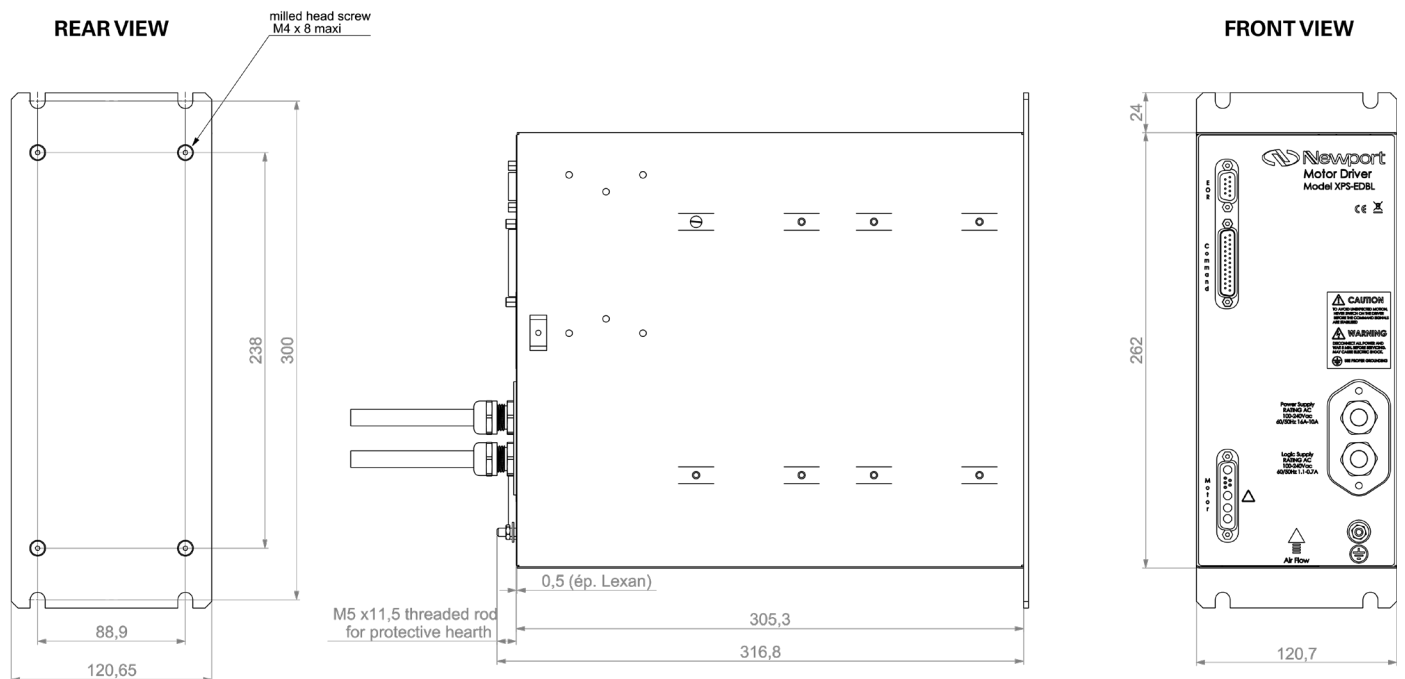

FRONT VIEW XPS-EDBL

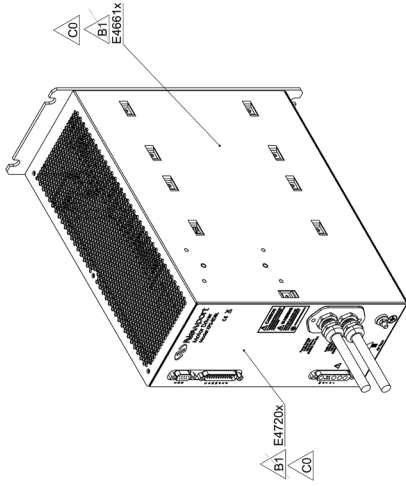

XPS-EDBL + BASE PLATE

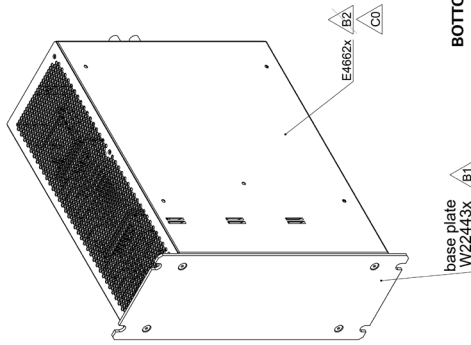

OPTIONAL FANS

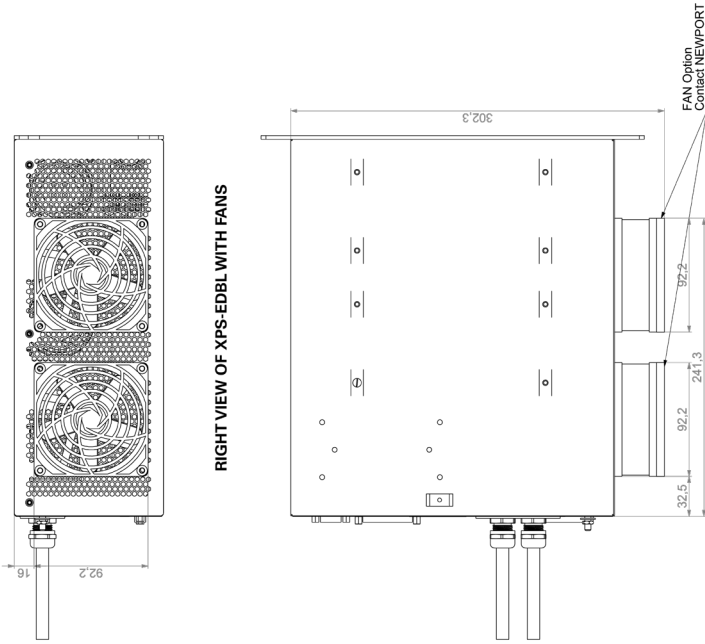

XPS-EDBL + OPTIONAL FANS

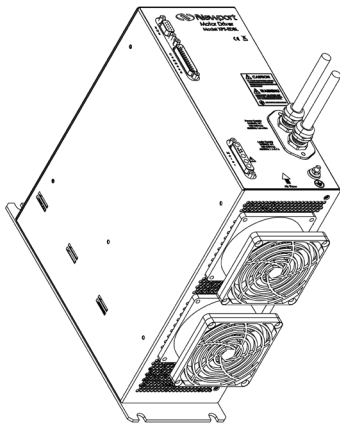

BOTTOM VIEW OF XPS-EDBL WITHOUT FANS

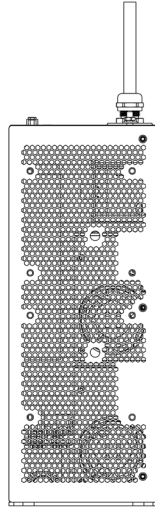

LEFT VIEW OF XPS-EDBL + CONNECTION CABLES

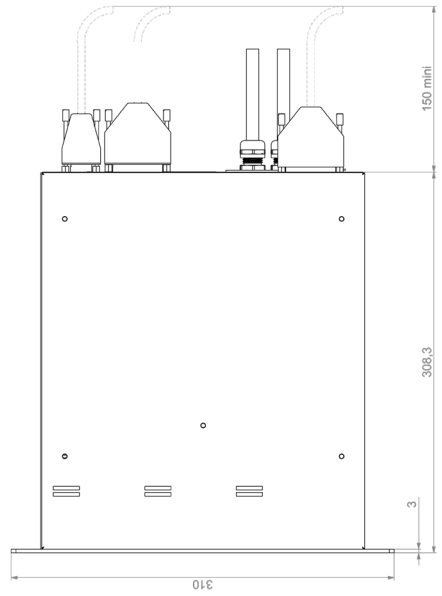

FRONT VIEW

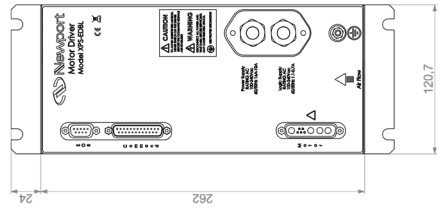

RIGHT VIEW OF XPS-EDBL WITHOUT FANS

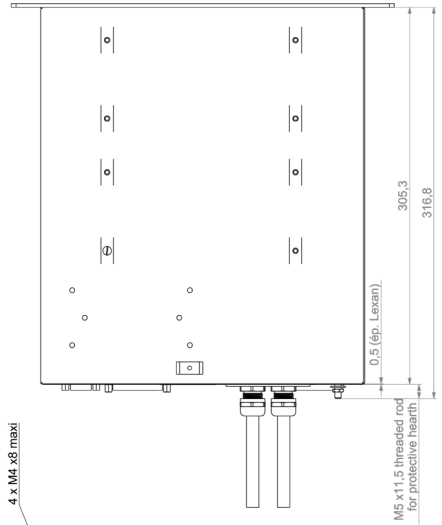

VIEW WITHOUT BASE PLATE

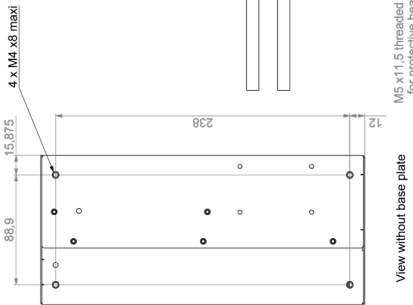

REAR VIEW

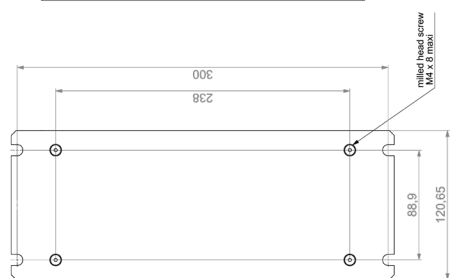

3.3.2 Power Plug

They should be cut and removed and the EDBL should be PERMANENTLY CONNECTED to an installation which includes the required switches, fuses and circuit breakers.



The AC POWER cable has 2 stickers: “POWER” and “E5084x” and the marking 3G1.5 mm².

The AC LOGIC cable has 2 stickers: “LOGIC” and “E5084x” and the marking 3G0.75 mm².

Do not remove the stickers when installing the driver permanently.

3.3.3 Wiring Earth-Ground

Panel wiring requires that a central earth-ground location be installed at one part of the panel. This electrical ground connection allows for each device within the enclosure to have a separate wire brought back to the central wire location. Usually, the ground connection is a copper plate directly bonded to the back panel or a copper strip with multiple screw locations.

3.3.4 Earth Grounding Paths

High-frequency noises from the PWM controlled power stage will find a path back to the drive. It is best that the path for the high-frequency noises be controlled by careful installation practices. The major failure in problematic installations is the failure to recognize that wire conductors have impedances at high frequencies. What reads 0 ohms on a handheld meter may be hundreds of ohms at 30 MHz.

Consider the following during installation planning:

1. Each device wired to earth ground should have its own conductor brought directly back to the central earth ground plate.
2. Use unpainted back panels. This allows a wide area of contact for all metallic surfaces reducing high frequency impedances.
3. Conductors made up of many strands of fine conductors outperform solid or conductors with few strands at high frequencies.
4. Motor cable shields should be bonded to the back panel.
5. Motor shields are best grounded at both ends of the cable.
6. Running motor armature cables with any other cable in a tray or conduit should be avoided. These cables can radiate high frequency noise that can couple into other circuits.

3.3.5 Installing the XPS-EDBL for Use with an XPS Controller



WARNING

- Do not open the protective conductive packaging until you have read the following, and are at an approved anti-static work station.
- Use a conductive wrist strap attached to a good earth ground.
- Always turn the controller's power OFF before installing a board.
- Always discharge yourself by touching a grounded bare metal surface or approved anti-static mat before picking up an ESD – sensitive electronic component.
- Use an approved anti-static mat to cover your work surface.

To install the XPS-EDBL, proceed as follows:

- Select an available slot on the XPS and remove the corresponding plate (1 screw)
- Insert the XPS-DRV00P board in the slot and tighten the locking screw
- Connect the 25-pin, male Sub-D connector to the XPS-DRV00P interface board terminal.



- Connect the 25-pin, female sub-D connector to the XPS-EDBL
- Connect the earth (ground) terminal to earth (ground) cable
- Connect the motor
- Make sure the circuit breakers are cutting the power supplies.
- Connect XPS-EDBL and XPS power cables to the circuit breakers terminals.
- Put the XPS controller switch on the ON position
- Close the additional enclosure
- Switch ON the LOGIC supply first
- Wait 30 seconds until the XPS boots
- Switch ON the POWER supply
- When you finish turn OFF the POWER supply first and then turn OFF the LOGIC supply.

3.4 Connection XPS- EDBL



WARNING

All Newport products are provided with standard cable lengths to 5m. The use of an extension cable is not advised as it might result in the degradation of the product's performance. Please contact Newport Corp. for any cable extension needs.

Motor poles

Usually the number of poles in the motor is not a concern to the actual application. However, it should be noted that each pole-pair of the motor requires an electrical cycle. Therefore, the speed of the motor should be limited to a value that enables the PI current loop to regulate correctly at the frequency given in the parameter stage.

However, setting this frequency to the maximum in all applications is not always appropriate as it will allow noise above the needed frequency to be fed back in the control loop and the system.

Motor Cabling

Motor cables are an integral part of a motor drive system. Several factors should be considered when selecting motor cables. Motor cables must have a good quality shield around them. The motor frame must also have a separate conductor to bring back to the drive amplifier to help quench current flows from the motor. Both the motor drain wire and the cable shield should be tied at both ends to the motor and to the drive amplifier.

Another consideration in selecting motor cables is the conductor-to-conductor capacitance rating of the cable. Small capacitance is desirable. Longer runs of motor cable can add motor capacitance loading to the drive amplifier causing undesired spikes of current. It can also cause coupling of noise into the earth ground, causing excessive noise as well. Typical motor cable capacitance ratings would be 50 pF(maximum) per foot of cable .

Another factor in picking motor cables is the actual conductor cross-sectional area. This refers to the conductor's ability to carry the required current to and from the motor. When calculating the required cable dimensions, consider regulatory agency requirements, safety requirements, maximum temperature that the cable will be exposed to, the continuous current flow through the motor, and the peak current flow through the motor. Typically, it is recommended that any motor cable is larger than 14 AWG.

The motor cable's length must be considered as part of the application. Motor cable length affects the system in two ways. First, additional length results in additional capacitive loading to the drive. The drive's capacitive loading should be kept to no more than 1000pF. Additionally, the length sets up standing waves in the cable, which can cause excessive voltage at the motor terminals.

The losses in the cable must be lower than the resistance of the motor ($R \ll R_{\text{motor}}$).

3.5 Configuration

Powering Up

After installing the XPS-EDBL driver, the XPS controller can now be powered on. However, the presence of this new driver requires updating the XPS controller Initialization file « system.ini ».



CAUTION

Do not power the EDBL until the controller is ready. Then, after the correct parameters are set, the axis can be initialized.

XPS Controller

For instructions on how to update the « system.ini » initialization file, refer to XPS-D Configuration Manual.

NOTE

If the new driver board and/or the stage are not automatically detected, the XPS firmware might need to be updated manually. Refer to chapter «Controller – Firmware update » of the XPS-D User Interface Manual documentation. The latest XPS firmware package can be downloaded from Newport ftp site at:

ftp://download.newport.com/MotionControl/Current/MotionControllers/XPS-D/Updates/

At the end of the start up procedure, the XPS controller has recognized the driver board and the stage. An example of the XPS Front panel/Move page is shown below.



System Stages Controller Files **Front panel** Terminal Data

Move Cycle Jog Spindle I/O control Device status

Move to position

Position	State	Action	Positioner	Parameters	Absolute move 1		Absolute move 2		Relative move
-0.0004951	7	INITIALIZE	RGV160BL.Pos	VIEW/SET		GO		GO	
		KILL ALL							

Axis initialization

The XPS-EDBL driver must be initialized to set all axis parameters. This can be done by clicking on the « Initialize » button:

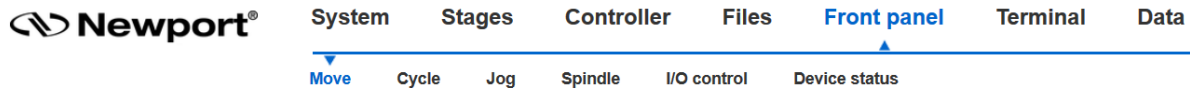

Move to position

Position	State	Action	Positioner	Parameters	Absolute move 1	Absolute move 2	Relative move
-0.0289141	42	HOME	RGV160BL.Pos	VIEW/SET	GO	GO	
		KILL ALL					

The axis must now be referenced by clicking on the « Home » button:



Move to position

Position	State	Action	Positioner	Parameters	Absolute move 1	Absolute move 2	Relative move
0	11	DISABLE	RGV160BL.Pos	VIEW/SET	GO	GO	
		KILL ALL					

The axis is now ready to be used.

3.6 Regenerative Energy Absorption

A motor coupled with a load has a certain amount of energy. This energy is mainly kinetic when the load is moving or rotating. When the system brakes, the energy must be either stored or dissipated. This is also sometimes the case when the system is at constant speed in descent direction.

In the example below, three-phase motors are used.

System energy

In a standard direct drive application, the energy balance can be written as:

$$E_{\text{REGEN}} = \underbrace{(E_K + E_P)}_{\text{System energy}} - \underbrace{(E_{Co} + E_F)}_{\text{system losses}} \quad (1)$$

Where:

- E_{REGEN} = Regenerative Energy to dissipate or Total energy of motor/load minus the system losses for one move [J]
- E_K = Kinetic energy of motor/load [J]
- E_P = Gravitational potential energy of motor/load [J]
- E_{Co} = Energy lost in the motor copper (Ohm losses) [J]
- E_F = Energy lost due to friction [J]

Torque motor case, standard configuration

EP term is equal to zero in this case

$$E_{\text{REGEN}} = \underbrace{\frac{1}{2} \cdot (J_M + J_L) \cdot \omega_M^2}_{\text{Kinetic energy}} - \underbrace{3 \cdot I_M^2 \cdot \left(\frac{R_M}{2}\right) \cdot t_d}_{\text{Copper losses}} - \underbrace{\frac{t_d \cdot \omega_M \cdot T_F}{2}}_{\text{Friction losses}} \quad (1a)$$

Where:

- JM = Rotor inertia [kgm²]
- JL = Load inertia [kgm²]
- ωM = Motor speed before deceleration [rad/s]
- IM = Motor current during deceleration [ARMS/phase]
- RM = Motor resistance [Ω] terminal to terminal + Cable resistance
- td = Time to decelerate [s]
- TF = Friction torque [Nm]

Linear motor case with gravitational potential energy (vertical):

$$E_{\text{REGEN}} = \underbrace{\frac{1}{2} \cdot (m_M + m_L) \cdot v_M^2}_{\text{Kinetic energy}} + \underbrace{(m_M + m_L) \cdot g \cdot (h_{\text{initial}} - h_{\text{final}})}_{\text{Gravitational potential energy}} - \underbrace{3 \cdot I_M^2 \cdot \left(\frac{R_M}{2}\right) \cdot t_d}_{\text{Copper losses}} - \underbrace{\frac{t_d \cdot v_M \cdot F_F}{2}}_{\text{Friction losses}} \quad (1b)$$

Where:

- mM = Motor mass [kg] moving part of motor only
- mL = Load mass [kg]
- vM = Motor speed before deceleration [m/s]
- g = Gravitational acceleration [m/s²]
- hinitial = Initial load altitude [m]
- hfinal = Final load altitude [m]
- IM = Motor current during deceleration [ARMS/phase]
- RM = Motor resistance [Ω] terminal to terminal
- td = Time to decelerate [s]
- FF = Friction force [N]

NOTE

For a constant speed system, all the terms of the equation (1b) have the same meaning except for:

- vM = Motor speed (constant) during the travel [m/s]
- IM = Motor current during travel at constant speed [ARMS/phase]
- Td = Time to travel [s]

Resistance value

$$R_{MAX} = \frac{U_{MAX}^2}{U_B \cdot I_M \cdot \sqrt{3}} \quad (2)$$

Where:

- R_{MAX} = Brake resistance maximum value [Ω]
- U_{MAX} = Maximum allowed BUS voltage [V]
- U_B = Motor back EMF less motor losses [V]
- I_M = Deceleration current in motor [ARMS/phase]

You must compare the value of R_{MAX} to R_{REGEN} and verify that:

$$R_{MAX} \leq R_{REGEN} \quad \text{where } R_{REGEN} = 100\Omega$$

U_B is calculated like this :

1. Torque motor case:

$$U_B = \underbrace{K_u \cdot \omega_M}_{\text{Back EMF}} - \underbrace{I_M \cdot \left(\frac{R_M}{2}\right)}_{\text{Phase voltage}} \cdot \sqrt{3} \quad (2a)$$

Where:

- K_u = Back EMF constant [V/(rad/s)] terminal to terminal

2. Linear motor case:

$$U_B = \underbrace{K_u \cdot v_M}_{\text{Back EMF}} - \underbrace{I_M \cdot \left(\frac{R_M}{2}\right)}_{\text{Phase voltage}} \cdot \sqrt{3} \quad (2b)$$

Where:

- K_u = Back EMF constant [V/(m/s)] terminal to terminal

The resistance dissipated power:

(All negative EM are set to zero)

$$P_{AV} = \frac{\sum_{i=1}^n E_{Mi}}{t_{CYCLE}} \quad (3)$$

Where:

- P_{AV} = Average power to be dissipated by the brake resistance [W]
- t_{CYCLE} = Cycle time of travel of the system [s]
- i = number of cycles of the system

You must compare the value of P_{AV} to P_{REGEN} and verify that:

$$P_{AV} \leq P_{REGEN} \quad \text{where } P_{REGEN} = 150 W$$

$$E_M > \frac{1}{2} * C * V^2 \quad \text{with } C = 300\mu F + \text{power supply}(100\mu F)$$

3.7 Running Performance Adjustments

The EDBL is commanded with +/-10V analog signals which represent U and V current targets. The current on the U&V phases of the motor is measured with shunt resistors and amplified before it is digitally converted.

Analog circuits present intrinsic offsets and are subject to temperature drifts. Offsets are automatically compensated on the EDBL on the current measurements.

This automatic correction is done when the driver is enabled; i.e. the INHIB signal transitions from High state to Low state.

Therefore, it is required that the U&V commands coming from the external controller are 0V and that the motor is not in motion so that it does not generate currents that would cause it to measure a false offset.

When automatic correction is done on a cold driver (which is powered on but has not been enabled and cycled with high current profiles), the offset will drift until the driver reaches the process temperature. Disabling the driver and enabling it quickly thereafter, allows the automatic correction to be done at the process temperature, therefore removing any temperature related offset.

4.0 Troubleshooting

4.1 Preventative Measures

This section explains the preventative checks and analysis tools required to determine the cause of trouble when it occurs.

- Check the Power Supply Voltage and make sure that the power supply is correct.
- Disconnect any cables before checking if they have burned out. Even if you have checked the conduction of the wiring, there is a risk of conduction due to the return circuit.
- When performing tests, first check that there are no personnel inside the machine facilities, and that you can immediately stop the machine using an emergency stop before performing the tests.
- Do not make any extreme adjustments or parameter setting changes. Doing so may result in unstable operation and injury.

NOTE

If the current readings are not the expected values, probe the motor phase currents at the motor cables with a snap-on hall-effect current sensor. If the current is not seen when commanding voltages, check for phase-to-phase continuity and proper resistance when the motor is disconnected.

4.2 Troubleshooting by Means of Operating Status

If an error occurs, check the type of error using the operation status, verify the cause, and take appropriate action.

Symptom	Probable cause	Items to check	Actions
EDBL is overheating.	The ambient temperature is too high.	Check that the ambient temperature around the Servomotor is no higher than 40° C.	Lower the ambient temperature to 40° C or less. (Use a cooler or fan.)
	Ventilation is obstructed.	Check whether anything is blocking ventilation.	Ensure adequate ventilation.
	There is an overload.	Check status.	Lighten the load or reduce motion cycles.
There is unusual noise.	The machinery is vibrating.	Inspect the machinery to see whether there are any foreign objects in the moving parts, or whether there is any damage, deformation, or looseness.	Fix the problems causing vibration.
	Problem in the loop.	-	Use auto-tuning or adjust parameters.

4.3 Overload

Before running the driver, make sure the maximum load indicated in the datasheet is not exceeded.

If an overload does occur, first clear the cause of the error and then wait at least one minute for the driver temperature to drop before turning the power on again.

4.4 Maintenance

The XPS-EDBL driver requires no particular maintenance. Nevertheless, it contains an electronic circuit board that must be handled with caution. User should not open the EDBL, in case of problem please contact Newport

Error reporting

In case of a malfunction, the XPS-EDBL driver will signal a "Fault" output to the controller. At this point the XPS controller will automatically “kill” the axis. The XPS website allows checking the type of error(s) using the I2C bus.

Select FRONT PANEL/Device status and scroll down to Driver status section to display the current XPS-EDBL driver. The screenshot below shows an example of error reporting indicating a thermistor fault.

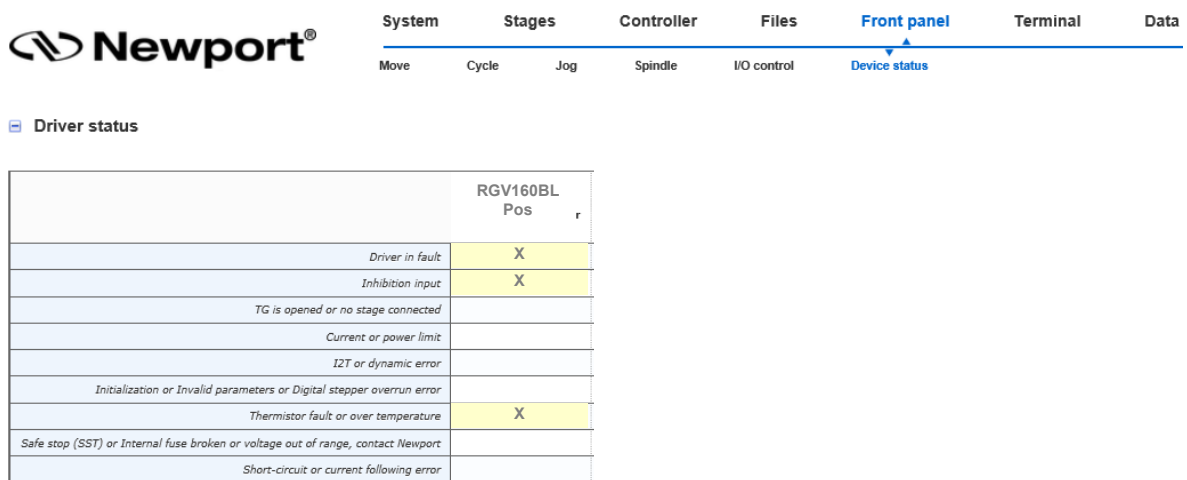

The screenshot shows the Newport website navigation menu with 'Front panel' selected, leading to 'Device status'. Below this, the 'Driver status' section is expanded to show a table of error conditions for an RGV160BL motor.

	RGV160BL Pos
Driver in fault	X
Inhibition input	X
TG is opened or no stage connected	
Current or power limit	
I2T or dynamic error	
Initialization or Invalid parameters or Digital stepper overrun error	
Thermistor fault or over temperature	X
Safe stop (SST) or Internal fuse broken or voltage out of range, contact Newport	
Short-circuit or current following error	

Following errors can occur on a XPS-EDBL driver board:

- a:** Short circuit, Current following error
- b:** Internal fuse broken, in this case you must contact Newport
- c:** Thermistors fault (driver, regeneration or motor)
- d:** Initialization error (Invalid parameters)
- e:** I2T (RMS current limit)
- f:** Current limit, Power limit
- g:** Not used
- h:** Inhibit input
- i:** Driver fault

Website error diagnosis

Errors “a” can be triggered either by a short circuit or by a regulation problem, i.e.: a following error of more than 5A. This could be due to a partial short circuit in the installation, or for example an initialization level too high. High initialization level may be required for some application with stages having high friction levels.

Errors “b, d and e” have straightforward interpretation.

Error c has multiple causes as there are multiple thermistors monitored. It can be triggered either because the driver becomes too hot (check its ventilation), because it is regenerating too much energy (check the energy profile of your application) or because the motor is too hot (check also the energy profile of your motions to check if the motor is correctly sized).

In any case, when this error occurs wait for the parts to cool down and take necessary actions to prevent this error to be further triggered.

Error “e” (RMS current limit) requires resetting the power supplies (POWER and LOGIC) of the driver to reinitialize the driver.

Error f can be either a current limit or, in the case of the EDBL version without fan, it will occur if the command sent to the driver is over the power limit of this version.

Axis initialization after an error

After cancelling the error, the axis must be re-initialized.

This can be done through the XPS Website FRONT PANEL/Move page by clicking on “Initialize”.



Move to position

Position	State	Action	Positioner	Parameters	Absolute move 1	Absolute move 2	Relative mc
-0.0004951	7	INITIALIZE	RGV160BL.Pos	VIEW/SET	GO	GO	
		KILL ALL					



Move to position

Position	State	Action	Positioner	Parameters	Absolute move 1	Absolute move 2	Relative mc
-0.0289141	42	HOME	RGV160BL.Pos	VIEW/SET	GO	GO	
		KILL ALL					

Then click “Home” to enable the axis ready for motion.

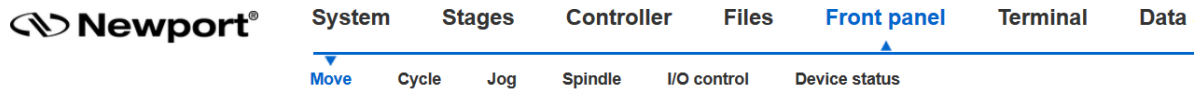

Move to position

Position	State	Action	Positioner	Parameters	Absolute move 1	Absolute move 2	Relative move
0	11	DISABLE	RGV160BL.Pos	VIEW/SET	<input type="text"/> GO	<input type="text"/> GO	<input type="text"/>
		KILL ALL					

The “Driver status” shouldn't report any fault.



Driver status

	RGV160BL Pos
Driver in fault	
Inhibition input	
TG is opened or no stage connected	
Current or power limit	
I2T or dynamic error	
Initialization or Invalid parameters or Digital stepper overrun error	
Thermistor fault or over temperature	
Safe stop (SST) or Internal fuse broken or voltage out of range, contact Newport	
Short-circuit or current following error	

Service and Repair



CAUTION

Never attempt to disassemble any element of the driver. Disassembly of an element can cause a malfunction of the driver.

CAUTION

Any attempt to disassemble or repair a driver without authorization will void the warranty.

If you observe a malfunction in your driver, please contact Newport immediately to arrange for a repair.

The product has no user serviceable parts and should be returned to Newport for repair.

The product should be returned in its original packaging if possible; otherwise, reasonable care should be taken in the packing of the product to ensure that no damage occurs during transport.

Enclosure Cleaning

The XPS-EDBL enclosure should only be cleaned with a dry cloth.

Packaging

During transport our products are protected by suitable packaging. This is entirely environmentally friendly and should be taken for recycling.

Service Form

Your Local Representative

Tel.: _____

Fax: _____

Name: _____

Return authorization #: _____

Company: _____

(Please obtain prior to return of item)

Address: _____

Date: _____

Country: _____

Phone Number: _____

P.O. Number: _____

Fax Number: _____

Item(s) Being Returned: _____

Model#: _____

Serial #: _____

Description: _____

Reasons of return of goods (please list any specific problems): _____



Visit Newport Online at:
www.newport.com

North America & Asia

Newport Corporation
1791 Deere Ave.
Irvine, CA 92606, USA

Sales

Tel.: (800) 222-6440
e-mail: sales@newport.com

Technical Support

Tel.: (800) 222-6440
e-mail: tech@newport.com

Service, RMAs & Returns

Tel.: (800) 222-6440
e-mail: service@newport.com

Europe

MICRO-CONTROLE Spectra-Physics S.A.S
9, rue du Bois Sauvage
91055 Évry CEDEX
France

Sales

Tel.: +33 (0)1.60.91.68.68
e-mail: france@newport.com

Technical Support

e-mail: tech_europe@newport.com

Service & Returns

Tel.: +33 (0)2.38.40.51.55

