

**INFRARED WAVELENGTH
HELIUM-NEON LASER SYSTEM
USER'S GUIDE TO OPERATION**

Research Electro-Optics
5505 Airport Boulevard
Boulder, CO 80301
Phone: (303) 938-1960
Fax: (303) 447-3279

LAP-037
Revision C
DCO #: 867
03/15/2004

PREFACE

This User's Guide is designed to assist you in the daily operation and maintenance of your new Helium-Neon (He-Ne) laser system. The information contained within this User's Guide should answer most of your questions concerning the use and operation of this laser system.

This guide contains six sections:

Section I: Provides information on unpacking your laser system.

Section II: Provides important safety information for operating the laser system.

Section III: Provides instructions on connecting your laser to the power supply, proper operating procedures, and some general information about your laser system.

Section IV: Describes procedures for basic troubleshooting of your laser system.

Section V: Gives information concerning the warranty of the laser system. It also provides instructions for returning the laser for service.

Section VI: Provides the specifications for your laser system.

SECTION I UNPACKING

This section describes:

- how to unpack and inspect your laser system
- what is included in your shipment

NOTE: PLEASE KEEP ALL PACKING MATERIALS FROM YOUR SHIPMENT IN CASE YOU NEED TO RETURN ANYTHING!!

UNPACKING

- 1) Carefully remove the laser head (or tube) from the shipping container.
- 2) Inspect the laser head (or tube) for any obvious damage as follows:
HEAD:
 - Check for broken legs at the end of the laser power cord.
 - Gently turn laser head upside down, listen for any noise.
 - For dual line infra-red lasers (1152 nm/3392 nm), check the included filter assembly for any loose or damaged filters.**TUBE:**
 - Check for broken or cracked glass.
 - If included, check the power cable for any damage.
- 3) Remove the power supply from the shipping container (if included).
- 4) Inspect the power supply for damage as follows:
PACKAGED POWER SUPPLY:
 - Ensure there is one key included and that it is not bent.
 - Check the housing for any damage.
 - Check the power cord for any damage.**OEM POWER SUPPLY:**
 - Check the module for any obvious damage.
 - Check that none of the wires or connectors are damaged or broken.
 - Ensure that a wiring diagram for your particular power supply model is included in Section VI.
- 5) If anything listed above is missing or damaged, please notify REO immediately! See Section V for information on returning the laser for repair.

NOTE: PLEASE KEEP ALL PACKING MATERIALS FROM YOUR SHIPMENT IN CASE YOU NEED TO RETURN ANYTHING!!

SHIPPING INVENTORY

The equipment included in this shipment should match the packing slip attached to the box. Matching the serial number(s) is an accurate way to check. If the shipment is incomplete or if an incorrect item was shipped to you, please notify REO immediately. See Section V for further information on returning the unit.

SECTION II LASER SAFETY

The laser described in this User's Guide has invisible light power. It is safe to operate provided that the user pays attention to all safety warnings. It is recommended that all personnel who will operate or be in the vicinity of the laser during operation read and be familiar with this manual as well as be made aware of the following safety warnings.

- 1) Never look directly into the laser light source or at scattering laser light from any reflective surface. Laser light is hazardous to the eyes. Never sight down the beam into the source.
- 2) Maintain experimental set-ups at low heights to prevent inadvertent beam-eye contact.
- 3) Whenever the laser is running and the beam is not in use, block the beam with either the shutter on the output aperture or with a non-reflective material (piece of dark colored paper, cardboard, etc.). Avoid direct exposure to the laser beam.
- 4) Ensure that the laser head is securely connected to the power supply. Failure to do so may result in shock.
- 5) High voltage is present at all times. Provide adequate insulation at the high voltage connections of an OEM laser tube.
- 6) Do not attempt to open the sealed laser housing. This will expose personnel to high voltage and dangerous radiation. It will also void your warranty.
- 7) Post warning signs in the area of the laser to alert other people.
- 8) Keep all unnecessary personnel out of the area where the laser is being used.
- 9) As a precaution against accidental exposure to either the laser beam or its reflection, operators should wear laser safety glasses designed for this type of laser.*

CAUTION: USE OF CONTROLS OR ADJUSTMENTS OR PERFORMANCE OF PROCEDURES OTHER THAN THOSE SPECIFIED HEREIN MAY RESULT IN HAZARDOUS RADIATION EXPOSURE. IT WILL ALSO VOID YOUR WARRANTY.

* Laser safety glasses are available from many companies, such as Newport at 1-800-222-6440 or www.newport.com.

CDRH REGULATIONS

All laser products manufactured on or after August 2, 1976 for sale in the United States must conform to the performance and safety regulations 21 CFR Subchapter J 1040.10 and 1040.11. This federal regulation is administered by the National Center for Devices and Radiological Health (CDRH, formerly known as BRH, the Bureau of Radiological Health) under the Food and Drug Administration. All end users (including OEM) must always purchase CDRH compliant laser systems, except for replacement parts for products manufactured prior to August 2, 1976. It is the responsibility of the manufacturer of the final product or system to ensure that the CDRH requirements are met by that product or system.

Each REO Helium-Neon laser system, which is certified to be in compliance with the CDRH regulations, is equipped with a key-switch, remote interlock connector, laser radiation emission indicator (on the front of the power supply), time delay relay (built into the power supply), a beam attenuator (or shutter, located in the front bezel of the laser housing), and all appropriate warning labels. OEM power supplies come equipped with a built-in time delay relay. Again, it is the responsibility of the manufacturer of the final product or system to ensure that the CDRH requirements are met by that product or system.

For further information and assistance on laser safety, contact the following agencies:

Laser Institute of America
13501 Ingenuity Drive, Suite 128
Orlando, Florida 32826
** Safety Guides **

American National Standards Institute, Inc.
25 West 43rd Street
New York, NY 10036
** Safety Guides **

Food and Drug Administration
Center for Devices and Radiological Health
2098 Gaither Road
Rockville, MD 20850

CE COMPLIANCE

For European customers who require a CE approved laser system, REO certifies that our laser heads and lab power supplies meet the appropriate CE requirements. In order for the CE regulation to be met, all REO lab power supplies must be used with an input line cord with a length of 3 meters or less. The factory included line cord has a length of approximately 2 meters. Other cords may be used, but they must have a length of no longer than 3 meters in order for the laser system to remain CE compliant.

SECTION III INFORMATION, ASSEMBLY, and OPERATION

This section:

- provides some general information on your laser system
- describes how to assemble your laser system
- describes how to operate your laser system

GENERAL INFORMATION

LASER HEADS

All laser heads are equipped with a beam attenuator (or shutter) installed in the front bezel of the laser housing, and a six-foot long high voltage coaxial cable terminated with an Alden 8102M male high voltage connector. This allows for connection to most standard power supplies. REO laser heads are designed to operate at an optimum performance level when used with an REO power supply. They will also operate with a customer furnished power supply that is capable of providing the start voltage, operating current, and operating voltage requirements listed in the specifications in Section VI. Please contact REO if you have any questions concerning power supply compatibility.

All multi-line laser heads (1152 nm/3392 nm) are equipped with a filter assembly attached onto the front bezel of the laser. It may be either a three-position or a four-position filter. With the three-position filter assembly, position one blocks the beam completely, with position two allowing both wavelengths to be emitted. Position three blocks out the 1152 nm line, thus allowing only the 3392 nm line to be emitted. With the four-position filter assembly, positions one, two, and three are the same as in the three-position filter assembly, with position four allowing only the 1152 nm line to be emitted. The three-position filter assembly comes standard with the multi-line models, and the four-position filter assembly (part number 30648) is available upon request for an additional charge.

The cylindrical construction of the laser head allows for easy mounting in ring clamps, V-blocks, or similar mounting hardware without affecting the laser's alignment. When mounting the laser head, we recommend using a cushion material, such as foam or rubber, in between the mounting and the laser head. This will prevent the laser housing from becoming damaged. The front bezel has four each 4-40 Unified National Coarse Thread (UNC) holes to secure the optional accessory mounting ring. The ring (part number 30646), which is available for purchase from REO, incorporates 1" diameter, 32 threads-per-inch (TPI) female threads.

REO lasers are also available as OEM products. They are usually sent as a bare tube, with several options for electrical connections. We offer an attached ground wire, an Alden 8102M male high voltage connector with 12" cord and an in-line resistor, the previously mentioned cord terminated with alligator clips, or a separate resistor assembly that you install yourself. You may also combine the ground wire with any of the above high voltage connections.

LASER POWER SUPPLIES

Three options are available when purchasing a power supply from REO. The packaged power supply is available in two forms, a Laboratory Power Supply (hence the LPS), and a CE certified Laboratory Power Supply, (hence the CPS). Both are enclosed in a protective housing and are equipped with a built-in 3-5 second time delay, an Alden 8102F female high voltage connector, a key lock switch with one removable key, a laser radiation emission indicator, and a remote interlock connector. The OEM power supply comes as a bare "brick" with an Alden 8102F female high voltage connector attached to allow for use with the REO laser head. Power supplies are available for use with both 115 VAC and 230 VAC inputs. Other voltages are also available upon request.

ASSEMBLY OF THE LASER SYSTEM

PACKAGED POWER SUPPLY

- 1) Plug the laser power cord into the rear of the power supply.
- 2) With the key switch in the front of the power supply turned off, plug the power supply into a power source that will supply the specified input voltage for your system.
NOTE: The input power cord is a 3-wire cable. Make sure to use a suitable grounded power outlet.

OEM POWER SUPPLY

NOTE: DO NOT APPLY POWER TO THE POWER SUPPLY UNTIL IT IS CONNECTED TO THE LASER.

- 1) If your power supply is equipped with an Alden 8102F female connector, plug the laser power cord into this connector.
- 2) If your power supply is equipped with "flying leads," ensure your laser is properly connected as follows:
 - A) Connect the red high voltage wire to the anode pin (the metal pin that sticks out of the neck of the laser.)
 - B) Connect the black ground wire to the ground strap (if included) or to the metal body of the tube.
- 3) If your power supply does not have a line cord for the input power, connect it to the power source according to the included wiring diagram. If you have any questions, please call REO for assistance.

OPERATION

- 1) When the laser and power supply have been properly connected (following the above steps), open the shutter located at the front of the laser housing. The shutter is open when the slot is lined up parallel with the housing.
- 2) Apply power to the laser by "turning on" the power supply. This is done in one of two ways; either by turning the key switch to the "ON" position or by applying power to the power supply. On the packaged power supply, the emission indicator will illuminate immediately, indicating that power has been applied to the laser and that laser emission can be expected in approximately 3-5 seconds. If the laser fails to operate, please refer to Section III for some basic troubleshooting steps.

CAUTION:THE USE OF CONTROLS OR ADJUSTMENTS OR PERFORMANCE OF PROCEDURES OTHER THAN THOSE SPECIFIED HEREIN MAY RESULT IN HAZARDOUS RADIATION EXPOSURE (FDA CAUTION STATEMENT 21 CFR 1040.10(h)(1)(IV)). IT WILL ALSO VOID YOUR WARRANTY.

UNAUTHORIZED MODIFICATIONS TO THE LASER OR POWER SUPPLY MAY CAUSE IRREVERSIBLE DAMAGE TO THE SYSTEM, AS WELL AS RESULT IN POSSIBLE HAZARDOUS RADIATION EXPOSURE. THESE MODIFICATIONS WILL ALSO VOID ALL WARRANTIES. REPAIRS TO SUCH MODIFIED EQUIPMENT WILL BE CHARGED AT THE CURRENT REPAIR RATE, PLUS THE COST OF ANY REQUIRED PARTS.

SECTION IV BASIC TROUBLESHOOTING

The He-Ne laser is very simple to operate and maintain. Once power is applied to the laser, it should emit a beam of light within 3-5 seconds. If it doesn't, here are a few quick checks you can perform to troubleshoot your laser system.

NOTE: DO NOT LOOK DIRECTLY INTO THE LASER, EVEN IF NO VISIBLE LIGHT IS BEING EMITTED.

LAB POWER SUPPLY

- 1) Is it plugged into and receiving the correct input voltage? Check this by looking at the front panel of the power supply. There is a red switch on the left hand side. Ensure that it reads the same as your input source.
- 2) Is the remote plug, located on the rear panel of the lab power supply, installed? (Or is that circuit complete?)
- 3) Does the emissions indicator light, located in the upper left hand corner on the front panel, illuminate when the power supply is turned on?

OEM POWER SUPPLY

- 1) Is the power supply correctly wired into your power source? Verify this by comparing your wiring to the wiring diagram shown on the enclosed power supply specification sheet in Section VI.
- 2) Verify that your power source is properly functioning.

LASER

- 1) Is it plugged securely into the power supply?
- 2) Is the shutter open? (See Section II, Step 1 for instructions.)

If the above checks are all answered 'yes' and the laser is still not operating properly, the unit(s) will need to be returned to REO for evaluation and repair/replacement. Please see Section V for information on returning the unit(s).

SECTION V WARRANTY INFORMATION

WARRANTY POLICY

REO lasers and power supplies are warranted to be free from defects in materials and workmanship for a period of 12 months from the date of the initial shipment. This warranty does not extend to damage caused by negligent or improper handling in use, storage, or transportation, nor for products from which the original identification markings or labels have been removed, defaced, or altered.

Special contracts or contracts for non-standard products may have modified terms of warranty and, in such cases, the terms as stated in the individual contract must be signed by the duly authorized officer of REO and will supersede the standard terms. REO reserves the right to change our warranty policy without any prior notice. Please contact REO directly with any questions pertaining to your warranty.

REO will make the final determination as to the cause or existence of the defect and, at our discretion, repair or replace the products that prove to be defective during the warranty period. Products replaced under warranty will be warranted only for the balance of the warranty period of the originally supplied equipment. Additionally, any purchased replacement parts, i.e. laser tubes, power supply modules, etc., are warranted for a six-month (6) period.

This warranty extends only to the original purchaser of the equipment from REO, and is not transferable. The purchaser must notify REO within 15 days of first noticing the defect and promptly return the defective product before the expiration of the warranty period. Products returned from persons not employed by the original purchaser will not be evaluated without prior consent from the original buyer.

Products believed by the purchaser to be defective shall be returned to REO. Transportation, insurance, duties, etc., are to be paid by the purchaser. Repaired or replaced products will be returned to the purchaser by REO, F.O.B. city of destination, domestic as well as foreign territories. REO will not be responsible for any duties, levies, taxes, etc., on returned items.

WARRANTY PROCEDURE

Review the terms of your purchase and the date of shipment to determine the validity of your warranty claim. Warranty claims should only be made for products that are within the terms of the warranty policy. However, out-of-warranty items may be returned for evaluation at no charge.

Prior to returning any unit for repair or evaluation, please contact REO either by phone at (303) 938-1960 or by fax at (303) 447-3279 to obtain authorization to return the unit in the form of a Return Authorization number. This number is valid for a set period of time; 30 days for domestic customers, 45 days for foreign customers. If the unit is not received within this time frame, the authorization number will be closed out and you will need to call to obtain a new authorization number. For returns in foreign countries where representation is present, please contact your distributor. For customers in the U.S.A. and countries where distributorships and/or representation is not available, all claims and correspondence should be addressed to:

Research Electro-Optics
Attn: Laser Service Department
5505 Airport Boulevard
Boulder, Colorado 80301
Ref: Return Authorization Number

Please be prepared to furnish the following information when requesting an authorization number:

- a. Product model number and serial number
- b. Date of shipment/purchase
- c. Brief description of problem/failure
- d. Name and phone number of contact person at your organization.

Obtain REO instructions for transportation and packaging, and ship the product (freight and insurance prepaid) with the proper documentation containing the authorization number and the information specified above. Please ensure the authorization number is visible on the front of the shipping container.

REO will advise the purchaser of its evaluation results at the earliest possible time. Providing complete information as requested will help to expedite this process. For products outside of their warranty period, an evaluation will be made at no charge and a cost estimate for repair/replacement will be issued. Only after receiving authorization (in the form of a Purchase Order) will any repair/replacement work be performed. Charges for repair work will be billed at the current repair rate (available upon request from REO) plus the cost of any additional required parts. Repair work will be warranted for a period of 6 months from the date of shipment.

SECTION VI LASER SPECIFICATIONS

The following page(s) contain detailed information concerning your specific laser system. Please feel free to contact the laser department at REO if you have any questions concerning your laser system. REO can be reached at (303) 938-1960 or by fax at (303) 447-3279.

TECHNICAL DATA

R-40136

CYLINDRICAL HELIUM-NEON LASER HEAD

Wavelength	1.15 μ m
Minimum Output Power	1.0 mW
Power 3 Seconds After Turn-On	> 75%
Polarization	Linear > 500:1
Mode Structure	TEM ₀₀ > 99%
Beam Diameter	1.09 mm
Beam Divergence	1.34 mrad
Longitudinal Mode Spacing	375 MHz
Beam Drift After 20 Minute Warm-Up	< 0.2 mrad
Long Term Beam Drift	< 0.05 mrad
Noise (30 Hz - 10 MHz)	< 1% rms
Starting Voltage	< 10 kVDC
Operating Voltage	2700 VDC
Series Resistors in Housing	94 K Ω
Operating Current	6.50 mA
Shock	15 g for 11 msec
Weight	700 grams
Dimensions	
Length	482.6 \pm 1.0 mm (19.00 \pm 0.04")
Diameter	44.5 \pm 0.5 mm (1.75 \pm 0.02")
Maximum Output Power	5.0 mW
CDRH Classification	IIIb
CE Classification	3B
Recommended Power Supply	32882

ENVIRONMENTAL SPECIFICATIONS

Temperature	<u>Operating</u> -20 - +70° C	<u>Non-Operating</u> -40 - +80° C
Humidity	\leq 80%	\leq 95%
Altitude	0-3,000 meters	0-6,000 meters

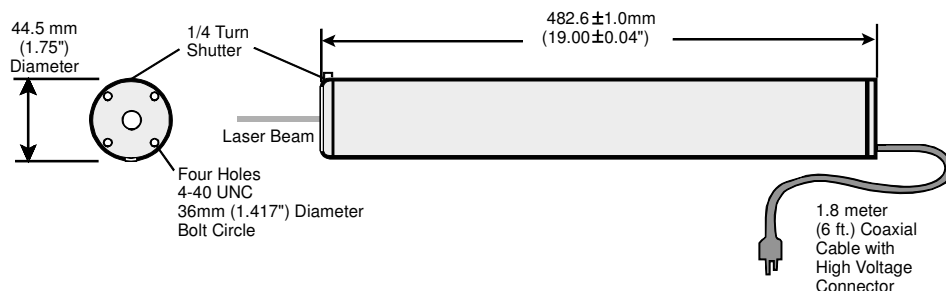

Research Electro Optics, Inc.
5505 Airport Boulevard Boulder, Colorado 80301
 Phone - (303) 938-1960 Fax - (303) 447-3279

Operating Instruction for HCU Power Supplies

HeNe Control Unit Series Power Supplies (39783, 39784, 39785, 39786)

Introduction

The HCU is a turn-key power supply for HeNe laser tubes that incorporates all of the appropriate safety features required by US Federal regulations. This unit is RoHS compliant.

Installation

The HCU will not operate until the fuse assembly is correctly installed. (See Fig 1) The enclosed fuse assembly can be found with a 250V - 5A slow blow fuse installed. Note: USE ONLY 250V-5A SLOW BLOW FUSES WITH THIS PRODUCT. A component within this fuse assembly is the input line voltage selector. The input line voltage selector configures the correct input line voltage for the local environment. This can be accomplished by sliding the input line voltage selector into the side of the fuse assembly. The desired input line voltage can be seen right side up in the window on the face of the fuse assembly. See Figure 1 for the proper voltage selection for your region of the world.

NOTE: FAILING TO SELECT THE CORRECT INPUT LINE VOLTAGE WILL RESULT IN FAILURE OF THE UNIT AND WILL VOID THE WARRANTY. Once the correct line voltage is selected, insert the fuse assembly into the power cord connector located on the back of the unit. The fuse assembly will be flush with the face of the AC connector when properly installed. Once the fuse assembly and voltage selector are correctly installed, insert the supplied UL rated, US IEC320 Female to Nema 5-15P power cord into the HCU power unit. Note: Non-US power cables must be supplied by the user.

To ensure proper and optimal laser operation, only use the HCU power supply that is appropriate for the HeNe laser tube in use.

Fuse Replacement:

To remove the fuse assembly, insert a flat blade screw driver into the groove on top of the fuse assembly and gently pry it from the power cord connector. Remove the fuse and replace with a 250V - 5 Amp slow blow fuse (Fuse Type 2AG). While replacing the fuse assembly as described above, ensure that the input voltage selector is still properly configured.

Before the unit can be operated, the laser tube must be connected to the HCU power supply. Do so by inserting the high voltage connector from the HeNe laser tube into the corresponding high voltage connector of the power supply. Check for proper orientation of the high voltage connector. It is polarized and will only fit when properly oriented. Insert the connector firmly and fully into the HCU power supply. Failure to fully engage this connector could result in poor laser operation and damage to both high voltage connectors.

Remote Interlock Operation

To use the remote interlock connector, remove the shorting conductor from the connector provided. The connector may then be wired into the users interlock system. The circuit is designed to activate the laser output when the two contacts of the connector are shorted together. This can be achieved via a simple switch or with relay contacts.

The voltage on this connector is 5VDC and is generated internally within the HCU. It is completely isolated from the AC line voltage. Failure of the remote interlock feature due to improper application of external voltages is not covered by warranty.

Operating Procedures

The system is equipped with a key switch located on the front panel. This is used by the customer to activate and deactivate the laser. A 5-second delay will begin after the key switch is turned to the 'ON' position. The emissions indicator on the front panel will come on to warn of eminent laser emission. The laser system will be 'OFF' when the key is in the vertical position.

The laser emissions can be controlled from the remote interlock connector. If the factory supplied remote interlock plug is removed while the laser is in operation, laser emissions will cease immediately. If the remote interlock plug is inserted into the remote interlock connector, laser emissions will resume after a 3-5 second safety delay. If the remote interlock connector has been interfaced to external circuits, laser emissions will be controlled in an identical manner.

Caution: Use of controls or adjustment or performance of procedures other than those specified herein may result in hazardous radiation exposure.

Figure 1

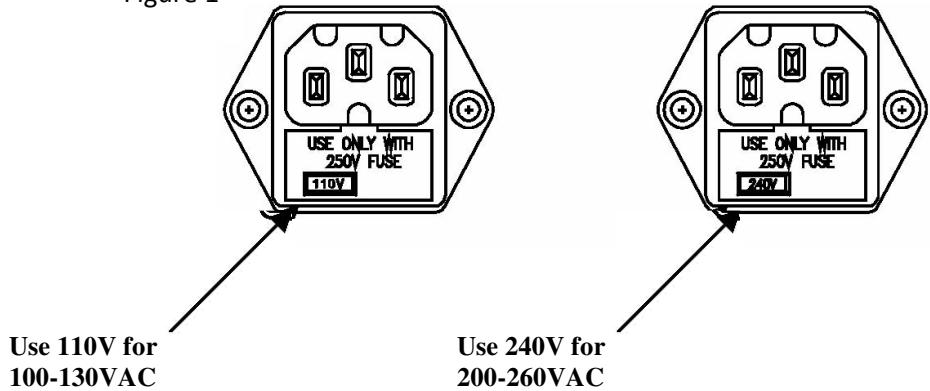

Figure 2

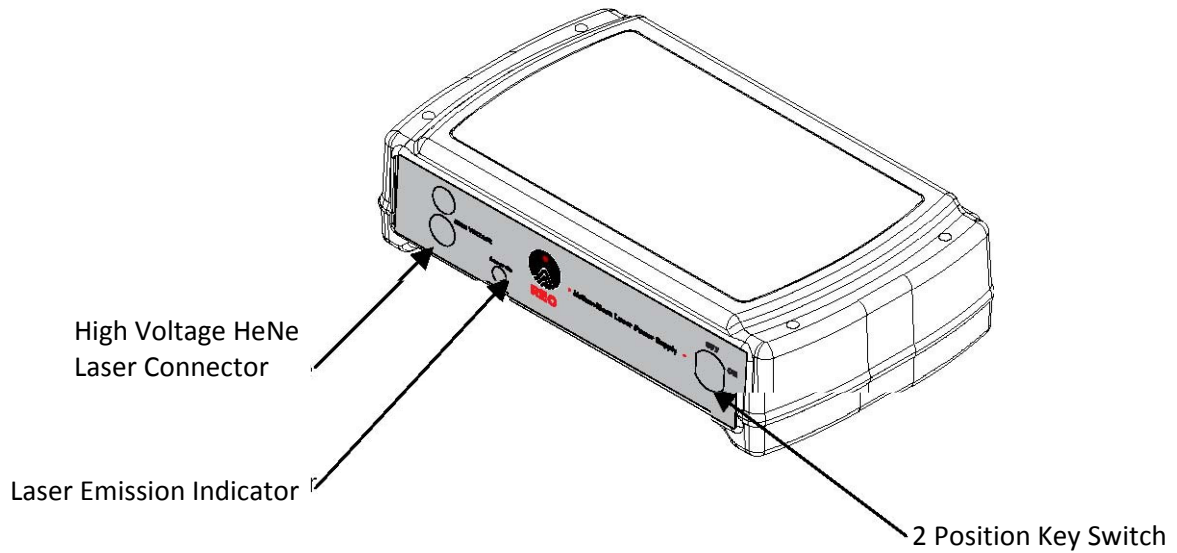
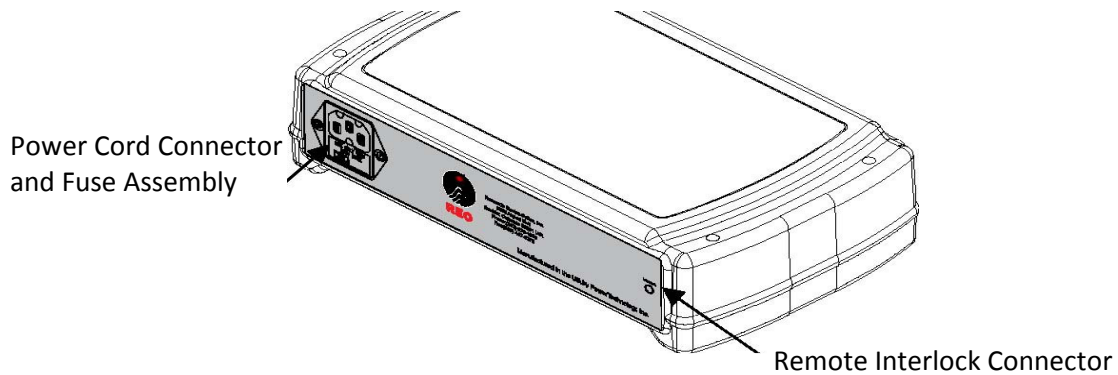

Figure 3



Maintenance & Service

The HCU power supply contain no user servicable parts. Return the HCU to REO for service.

Warranty

Unless otherwise noted, PTI warrants products to be free of defect in workmanship and material for a period of twelve (12) months from the date of shipment. The customer must make all claims under these warranties, and no claim will be accepted from a third party. Warranties are non-transferable. PTI will repair or replace product, provided customer notifies PTI of defect within warranty period and pre-authorizes return of product as outlined in "Returns" section above. Any product repaired or replaced under warranty is only warranted for the period of time remaining in the original warranty for the product. All repairs are warranted for a period of ninety (90) days. PTI's liability is limited to the replacement cost of product. PTI is not responsible for consequential damages.

Power Cord Connector and Fuse Assembly

Remote Interlock Connector



Newport Addendum to REO Laser User Documentation

The information in this document supersedes information contained in the Research Electro Optics, Inc. documentation supplied with your laser.

NOTE

The REO Model 3xxxx-Series lasers are intended for use in an industrial laboratory environment. Use of these products in other environments, such as residential, may result in electromagnetic compatibility difficulties due to conducted as well as radiated disturbances.

NOTE

The REO Model 3xxxx-Series lasers are designed to operate in a controlled electromagnetic environment; i.e., where R.F. transmitters such as mobile telephones may not be used in close proximity.

WASTE ELECTRICAL AND ELECTRONIC EQUIPMENT (WEEE)



This symbol on the product or on its packaging indicates that this product must not be disposed of with regular waste. Instead, it is the user responsibility to dispose of waste equipment according to the local laws. The separate collection and recycling of the waste equipment at the time of disposal will help to conserve natural resources and ensure that it is recycled in a manner that protects human health and the environment. For information about where the user can drop off the waste equipment for recycling, please contact your local Newport Corporation representative.

EUROPEAN UNION CE MARK



The presence of the CE Mark on a product means that this instrument has been designed, tested and certified compliant to all applicable European Union (CE) regulations and recommendations.

Newport Addendum to REO Laser User Documentation

EU Declaration of Conformity

We declare that the accompanying product, identified with the **CE** mark, complies with requirements of the Electromagnetic Compatibility Directive, 2004/108/EC and the Low Voltage Directive 2006/95/EC.

Model Numbers: 3xxxx Series Non-Stabilized HeNe LASERs

Year CE mark affixed: 2012

Type of Equipment: Electrical equipment for measurement, control and laboratory use in industrial locations.

Manufacturer: Research Electro-Optics, Inc
5505 Airport Blvd.
Boulder, CO., 80301
United States of America

Importer: Newport Corporation
1791 Deere Avenue
Irvine, CA 92606
United States of America

Standards Applied:

Compliance was demonstrated to the following standards to the extent applicable:

BS EN61326-1: 2006 “Electrical equipment for measurement, control and laboratory use – EMC requirements” (Laboratory)

This equipment meets the CISPR 11:2009+A1:2010 Class A Group 1 radiated and conducted emission limits.

BS EN 61010-1:2010, “Safety requirements for electrical equipment for measurement, control and laboratory use”.



Brian P. Turner
Laser Process Engineer
Research Electro-Optics, Inc.
5505 Airport Blvd, Boulder, CO 80301 USA



Mark Carroll
Sr. Director, Instruments Business
Newport Corporation
1791 Deere Ave, Irvine, CA 92606 USA

Newport Addendum to REO Laser User Documentation

Confidentiality & Proprietary Rights

Reservation of Title:

The Newport programs and all materials furnished or produced in connection with them ("Related Materials") contain trade secrets of Newport and are for use only in the manner expressly permitted. Newport claims and reserves all rights and benefits afforded under law in the Programs provided by Newport Corporation.

Newport shall retain full ownership of Intellectual Property Rights in and to all development, process, align or assembly technologies developed and other derivative work that may be developed by Newport. Customer shall not challenge, or cause any third party to challenge the rights of Newport.

Preservation of Secrecy and Confidentiality and Restrictions to Access:

Customer shall protect the Newport Programs and Related Materials as trade secrets of Newport, and shall devote its best efforts to ensure that all its personnel protect the Newport Programs as trade secrets of Newport Corporation. Customer shall not at any time disclose Newport's trade secrets to any other person, firm, organization, or employee that does not need (consistent with Customer's right of use hereunder) to obtain access to the Newport Programs and Related Materials. These restrictions shall not apply to information (1) generally known to the public or obtainable from public sources; (2) readily apparent from the keyboard operations, visual display, or output reports of the Programs; 3) previously in the possession of Customer or subsequently developed or acquired without reliance on the Newport Programs; or (4) approved by Newport for release without restriction.

Trademarks

The Newport logo is a registered trademark of Newport Corporation in Austria, Barbados, Benelux, Canada, the People's Republic of China, Denmark, France, Germany, Great Britain, Ireland, Japan, the Republic of Korea, Spain, Sweden, and the United States. Newport is a registered trademark of Newport Corporation in Austria, Barbados, Benelux, the People's Republic of China, Denmark, France, Germany, Ireland, Japan, the Republic of Korea, Spain, and Sweden.

Service Information

This section contains information regarding factory service for the source. The user should not attempt any maintenance or service of the system or optional equipment beyond the procedures outlined in this manual. Any problem that cannot be resolved should be referred to Newport Corporation.