

TRA Series

Compact Motorized Actuators



Newport®

Experience | Solutions

USER'S MANUAL

Precision Motion – **Guaranteed™**

Warranty

Newport Corporation warrants this product to be free from defects in material and workmanship for a period of 1 year from the date of shipment. If found to be defective during the warranty period, the product will either be repaired or replaced at Newport's discretion.

To exercise this warranty, write or call your local Newport representative, or contact Newport headquarters in Irvine, California. You will be given prompt assistance and return instructions. Send the instrument, transportation prepaid, to the indicated service facility. Repairs will be made and the instrument returned, transportation prepaid. Repaired products are warranted for the balance of the original warranty period, or at least 90 days.

Limitation of Warranty

This warranty does not apply to defects resulting from modification or misuse of any product or part.

CAUTION



CAUTION

Please return equipment in the original (or equivalent) packing.

You will be responsible for damage incurred from inadequate packaging if the original packaging is not used.

Warranty does not apply to damages resulting from:

- **Incorrect usage:**
 - Driven load greater than maximum specified load.
 - Actuator speed higher than specified speed.
 - **Improper grounding.**
 - Connectors must be properly secured.
 - When the load on the stage represents an electrical risk, it must be connected to ground.
 - Excessive or improper cantilever loads.
- **Modification of the actuator or any part thereof.**

This warranty is in lieu of all other warranties, expressed or implied, including any implied warranty of merchantability or fitness for a particular use. Newport Corporation shall not be liable for any indirect, special, or consequential damages.

No part of this manual may be reproduced or copied without the prior written approval of Newport Corporation.

This manual has been provided for information only and product specifications are subject to change without notice. Any changes will be reflected in future printings.

Table of Contents

Warranty	ii
EC Declaration of Conformity.....	v
Warnings	v
Definitions and Symbols.....	vi
Cautions	vii
<hr/>	
1.0 — Introduction.....	1
<hr/>	
2.0 — Description	1
2.1 Design Details	2
<hr/>	
3.0 — Characteristics.....	2
3.1 Definitions	3
3.2 Mechanical Specifications	3
3.3 Speed	4
3.4 Actuator Weights	4
<hr/>	
4.0 — Drive	5
4.1 DC-Motor Drive Version	6
4.2 Stepper Drive Version	6
<hr/>	
5.0 — Motor	6
5.1 UE10PP Motor Characteristics	6
5.2 Command Signals for the Stepper Motor.....	6
5.3 UE10MCC Motor Characteristics	6
5.4 Command Signals for the DC-Motor	7
5.5 Sensor Position.....	7
5.6 Feedback Signal Position	7
5.7 Pinouts.....	8
<hr/>	
6.0 — Connection to Newport Controllers.....	8
6.1 Warnings on Controllers	9
6.2 Connection.....	9
6.3 Cables	10
<hr/>	
7.0 — Connection to Non-Newport Electronics	10
7.1 Connections	11
<hr/>	
8.0 — Dimensions.....	11
<hr/>	

9.0	— Adapters for Opto-Mechanics	12
------------	--------------------------------------	----

10.0	— Maintenance	12
10.1	Maintenance	12
10.2	Repair	12
10.3	Calibration	12

	Service Form	13
--	--------------	----

EC Declaration of Conformity

TRA Series

EC Declaration of Conformity

following Annex II-1A
of Directive 2006/42/EC on machinery



The manufacturer:

MICRO-CONTROLE Spectra-Physics,
9 rue du Bois Sauvage
F-91055 Evry FRANCE

Hereby declares that the machinery:

- Description: " TRA "
- Function: Compact Motorized Actuators
- Models: TRA6/12/25/-CC/-PPD/-PPV6

– the technical file of which was compiled by:

Mr Dominique DEVIDAL, Quality Director,
MICRO-CONTROLE Spectra-Physics, Zone Industrielle - B.P.29
F-45340 Beauce La Rolande France

- complies with all the relevant provisions of the Directive 2006/42/EC on machinery.
- complies with all the relevant provisions of the Directive 2014/30/EU relating to electro-magnetic compatibility.

– was designed and built in accordance with the following harmonised standards:

- NF EN 61326-1:2013 « Electrical equipment for measurement, control and laboratory use – EMC requirements – Part 1: General requirements »
- NF EN 55011:2010/A1:2011 Class A

– was designed and built in accordance with the following other standards:

- NF EN 61000-4-2
- NF EN 61000-4-3
- NF EN 61000-4-4
- NF EN 61000-4-5
- NF EN 61000-4-6

ORIGINAL DECLARATION

Done in Beauce La Rolande on 26 June 2015
Dominique DEVIDAL
Quality Director

DC1-EN rev:A

Definitions and Symbols

The following terms and symbols are used in this documentation and also appear on the product where safety-related issues occur.

General Warning or Caution



The exclamation symbol may appear in warning and caution tables in this document. This symbol designates an area where personal injury or damage to the equipment is possible.

The following are definitions of the Warnings, Cautions and Notes that may be used in this manual to call attention to important information regarding personal safety, safety and preservation of the equipment, or important tips.



WARNING

Warning indicates a potentially dangerous situation which can result in bodily harm or death.



CAUTION

Caution indicates a potentially hazardous situation which can result in damage to product or equipment.

NOTE

Note indicates additional information that must be considered by the user or operator.

European Union CE Mark



The presence of the CE Mark on Newport Corporation equipment means that it has been designed, tested and certified as complying with all applicable European Union (CE) regulations and recommendations.

Warnings and Cautions



ATTENTION

This stage is a Class A device. In a residential environment, this device can cause electromagnetic interference. In this case, suitable measures must be taken by the user.

Warnings



WARNING

The motion of objects of all types carries potential risks for operators. Ensure the protection of operators by prohibiting access to the dangerous area and by informing the personnel of the potential risks involved.

WARNING

Do not use this actuator when its motor is emitting smoke or is unusually hot to the touch or is emitting any unusual odor or noise or is in any other abnormal state.

Stop using the actuator immediately, switch off the motor power and then disconnect the electronics power supply.

After checking that smoke is no longer being emitted contact your Newport service facility and request repairs. Never attempt to repair the actuator yourself as this can be dangerous.

WARNING

Make sure that this actuator is not exposed to moisture and that liquid does not get into the actuator.

Nevertheless, if any liquid has entered the actuator, switch off the motor power and then disconnect the electronics from power supply.

Contact your Newport service facility and request repairs.



WARNING

Do not insert or drop objects into this actuator, this may cause an electric shock, or lock the drive.

Do not use this actuator if any foreign objects have entered the actuator. Switch off the motor power and then disconnect the electronics power supply.

Contact your Newport service facility for repairs.

WARNING

Do not place this actuator in unstable locations such as on a wobbly table or sloping surface, where it may fall or tip over and cause injury.

If this actuator has been dropped or the case has been damaged, switch off the motor power and then disconnect the electronics power supply.

Contact your Newport service facility and request repairs.

WARNING

Do not attempt to modify this actuator; this may cause an electric shock or downgrade its performance.

Cautions

CAUTION

Do not place this actuator in a hostile environment such as X-Rays, hard UV,... or in any vacuum environment.

Only the TRA-PPV6 actuators are compatible and can be used in a vacuum environment up to 10^{-6} hPa.

CAUTION

Do not place this actuator in a location affected by dust, oil fumes, steam or high humidity. This may cause an electric shock.

CAUTION

Do not leave this actuator in places subject to extremely high temperatures or low temperatures. This may cause an electric shock.

- **Operating temperature: +10 to +35 °C**
 - **Storage temperature: -10 to +40 °C (in its original packaging)**
-

**CAUTION**

Do not move this actuator if its motor power is on.

Make sure that the cable to the electronics is disconnected before moving the actuator. Failure to do so may damage the cable and cause an electrical shock.

CAUTION

Be careful that the actuator is not bumped when it is being carried. This may cause it to malfunction.

CAUTION

When handling this actuator, always unplug the equipment from the power source for safety.

CAUTION

Contact your Newport service facility to request cleaning and specification control every year.

Compact Motorized Actuators

TRA Series

1.0 Introduction

This manual provides operating instructions for the actuator that you have purchased in the TRA Series:

- TRA-CC
- TRA-PPD
- TRA-PPV6⁽¹⁾

¹⁾ REMARK

Vacuum compatible actuators to 10^{-6} hPa. In this case, the max. speed and load capacity have to be divided by two.



TRA6, TRA12 and TRA25 motorized actuators.

RECOMMENDATION

We recommend you read carefully the chapter “Connection to electronics” before using the TRA actuator.



561D-XYZ positioner equipped with 3 TRA6 motorized actuators.

2.0 Description

The TRA series miniature motorized actuators are the latest addition to Newport's extensive range of precision positioning devices. They provide reliable motorized motion in a lightweight and very compact package and are a lower cost alternative to the popular CMA series.

The TRA actuators incorporate an excellent space saving design that allows them to be used with a wide variety of linear stages, mirror mounts, and OEM applications.

TRA6 and TRA12 models provide respectively 6 mm and 12 mm travel in a slim, only 15 mm diameter housing and are the recommended choice for motorizing Ultima or Suprema mirror mounts, 561 series linear stages, and 481 and RS65 rotation stages. They are also mechanical compatible with other Newport mechanical products, but due to the limited travel range of the actuator, the total travel range provided by the mechanic may not be achievable accessible.

The TRA25 provides 25 mm travel in a slightly larger package and is the recommended choice for motorizing linear stages and other devices.

To provide the best fit for your application's requirements, all TRA actuators are available in stepper, stepper vacuum and closed-loop DC servo motor versions.

To protect your investment, the TRA actuators include fixed integrated optical limit switches. These highly reliable switches also provide also a method for repeatable referencing/homing, for instance after shut-downs, for example.

2.1 Design Details

Base Material	Stainless steel body
Drive Mechanism	Rolled lead screw
Feedback	CC: Motor mounted rotary encoder, 64 cts/rev. PP: Open loop (no encoder)
Limit Switches	Optical switches, both ends
Origin	Uses negative travel limit for homing, typically <4 μm or ±2 μm repeatability
Motor	CC: DC Servo, UE10MCC PP: 2-Phase stepper motor, UE10PP, 20 steps/rev
Cable Length	TRA-PP & TRA-CC: 3 m TRA-PPV6: 1.5 m



NOTE

This product complies with the RoHS directive (Restriction of Hazardous Substances).

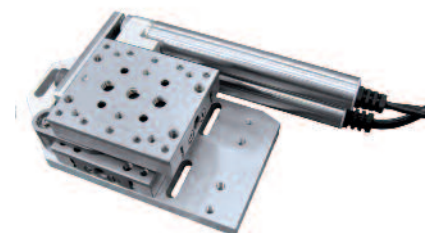

3.0 Characteristics

3.1 Definitions

Specifications of our products are established in reference to ISO 230 standard part II “Determination of accuracy and repeatability of positioning numerically controlled axes”.

This standard gives the definition of position uncertainty which depends on the 3 following parameters:

(Absolute) Accuracy

Difference between ideal position and real position.

On-Axis Accuracy

Difference between ideal position and real position after the compensation of linear errors.

Linear errors include: cosine errors, inaccuracy of screw or linear scale pitch, angular deviation at the measuring point (Abbe error) and thermal expansion effects. All Newport motion electronics can compensate for linear errors.

The relation between absolute accuracy and on-axis accuracy is as follows:

$$\text{Absolute Accuracy} = \text{On-Axis Accuracy} + \text{Correction Factor} \times \text{Travel}$$

Repeatability

Ability of a system to achieve a commanded position over many attempts.

Reversal Value (Hysteresis)

Difference between actual position values obtained for a given target position when approached from opposite directions.

Minimum Incremental Motion (MIM or Sensitivity)

The smallest increment of motion a device is capable of delivering consistently and reliably.

Resolution

The smallest increment that a motion device can theoretically move and/or detect. Resolution is not achievable, whereas MIM, is the real output of a motion system.

The testing of on-axis accuracy, repeatability, and reversal error are made systematically with test equipment in an air-conditioned room (20^{±1} °C).

A linear cycle with 21 data points on the travel and 4 cycles in each direction gives a total of 164 points.

Guaranteed Specifications

Guaranteed maximum performance values are verified per Newport's A167 metrology test procedure. For more information, please consult the metrology tutorial section in the Newport catalog or at www.newport.com

3.2 Mechanical Specifications



	TRA-CC	TRA-PP
Travel Range (mm)		6, 12 or 25
Minimum Incremental Motion (µm)	0.2	0.1
Uni-directional Repeatability ⁽¹⁾ (µm)	1	1
Bi-directional Repeatability ⁽¹⁾⁽²⁾ (µm)		3 or ± 1.5
On-Axis Accuracy ⁽¹⁾ (µm)		TRA6: 6 or ± 3 TRA12: 8 or ± 4 TRA25: 10 or ± 5
Maximum Speed (mm/s)	0.4 ⁽³⁾	TRA-PP: 0.4 ⁽³⁾ TRA-PPV6: 0.2
Axial Load Capacity [+Cx] (N)	60	TRA-PP: 60 TRA-PPV6: 30

¹⁾ Shown are peak to peak, guaranteed specifications or ±half the value as sometimes shown. For the definition of typical specifications which are about 2X better than the guaranteed values, visit www.newport.com for the Motion Control Metrology Primer.

²⁾ Backlash value is provided with each actuator.

³⁾ For axial loads over 45 N, the max. speed must be reduced to 0.3 mm/s.

NOTE

For TRA-PPV6 vacuum compatible actuators to 10⁻⁶ hPa, the max. speed and load capacity have to be divided by two.

3.3 Speed

The maximum speed of a **TRA-PP** or **TRA-CC** actuator with an axial load higher than **45 N** must be limited to **300 µm/s**.

3.4 Actuator Weights

Weights indicated into the below table are values for actuators with their cable.

	Weight [lb (kg)]
TRA6	0.51 (0.23)
TRA12	0.88 (0.40)
TRA25	1.32 (0.60)



Vacuum compatible TRA Series actuators can be used to upgrade our vacuum compatible mirror mounts to an automated vacuum compatible solution.

4.0 Drive

4.1 DC-Motor Drive Version

One DC-motor-driven configuration is available: TRA-CC.

DC-Motor Performance Specifications

	Resolution (μm)	Max. Speed ⁽¹⁾ (mm/s)	Motor
TRA-CC	0.0305	0.4	UE10MCC

¹⁾ See chapter 3.3

4.2 Stepper Drive Version

Stepper-motor-driven stages are offered in one half-step drive version: TRA-PP.

Stepper Motor Performance Specifications

	Resolution (μm)	Max. Speed ⁽¹⁾ (mm/s)	Motor
TRA-PP	0.0977	0.4	UE10PP

¹⁾ See chapter 3.3

NOTE

For TRA-PPV6 vacuum compatible actuators to 10^{-6} hPa, the max. speed and load capacity have to be divided by two.

5.0 Motor

5.1 UE10PP Motor Characteristics

Motor	Angle by Step ($^{\circ}$)	RMS Current per Phase (A)	Resistance (Ω)	Inductance (mH)	Newport Utilization
UE10PP	18	0.22	7.4	2.1	Mini-Step

5.2 Command Signals for the Stepper Motor

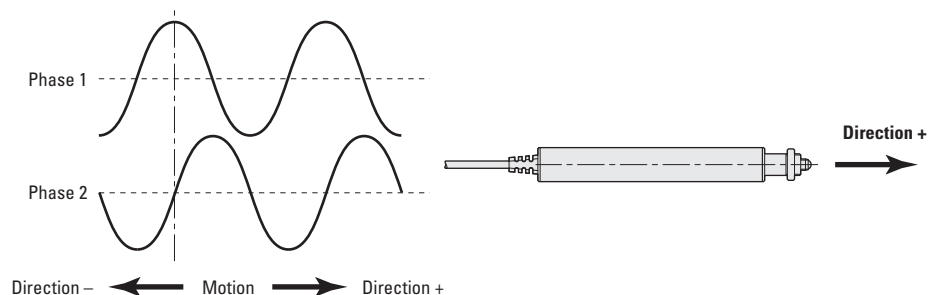

5.3 UE10MCC Motor Characteristics

Motor	Nominal Voltage (V)	Max. RMS Current (A)	Max. Peak Current (A)	Resistance (Ω)	Inductance (mH)
UE10MCC	12	0.075	0.15	114	0.92

5.4 Command Signals for the DC-Motor

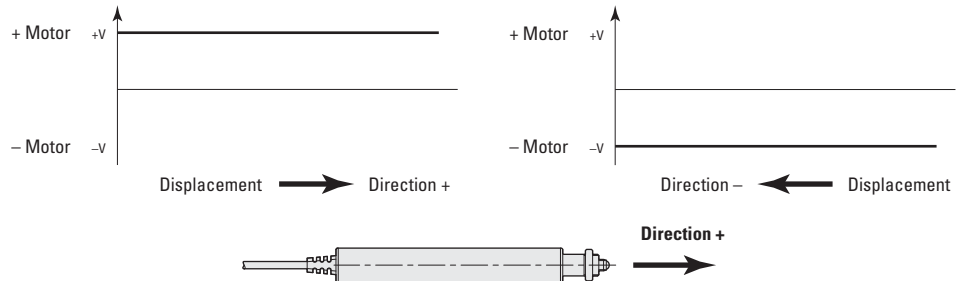

In the above drawings, + Motor signal is referred to - Motor signal.

- ① When the actuator moves in + Direction, the + Motor voltage is higher than - Motor voltage.
- ② When the actuator moves in - Direction, the + Motor voltage is lower than - Motor voltage.

5.5 Sensor Position

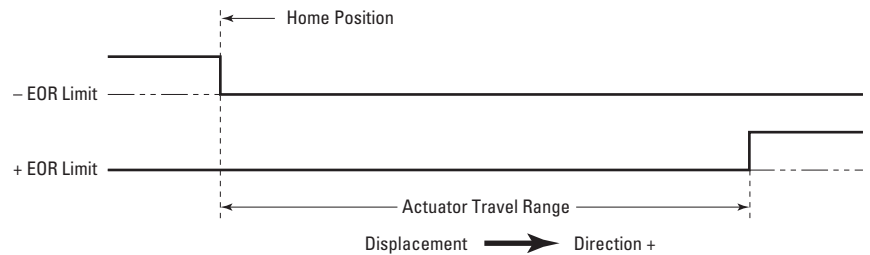

End-of-Run are 5 V open collector type.



CAUTION

“End-of-Run” are active signals and should not be connected to any other source.

5.6 Feedback Signal Position

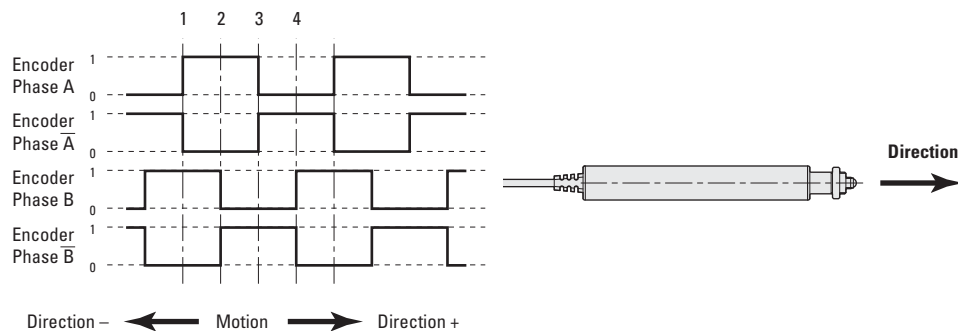

The incremental sensor consists of an optical scale and an encoder head. When the carriages of the stage move, the encoder head generates square signals in quadrature, sent to pins #19, #20, #23 and #24 of the SUB-D25 connector.

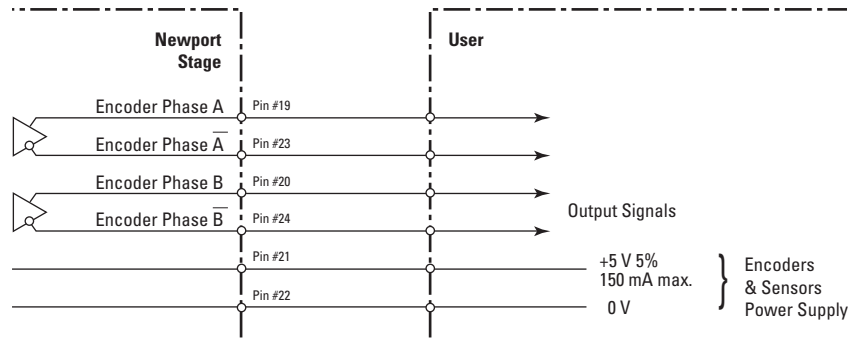

“Encoder” are “differential pair” (type RS-422) type output signals. Using these signals permits a high immunity to noise. Emission circuits generally used by Newport are 26LS31 or MC3487. Reception circuits to use are 26LS32 or MC3486.

5.7 Pinouts

The SUB-D25 connections for TRA actuators are given in the following table:

	TRA-PP UE10PP	TRA-CC UE10MCC
	1	1
	+ Phase 1	N.C.
	2	2
	+ Phase 1	N.C.
	3	3
	- Phase 1	N.C.
	4	4
	- Phase 1	N.C.
	5	5
	+ Phase 2	+ Motor
	6	6
	+ Phase 2	+ Motor
	7	7
	- Phase 2	- Motor
	8	8
	- Phase 2	- Motor
	9	9
	N.C.	N.C.
	10	10
	N.C.	N.C.
	11	11
	N.C.	N.C.
	12	12
	N.C.	N.C.
	13	13
	Reserved ⁽¹⁾	Reserved ⁽¹⁾
	14	14
	Ground	Ground
	15	15
	N.C.	N.C.
	16	16
	N.C.	0 V Logic
	17	17
	+ End-of-Run	+ End-of-Run
	18	18
	- End-of-Run	- End-of-Run
	19	19
	N.C.	Encoder Phase A
	20	20
	N.C.	Encoder Phase B
	21	21
	+5 V	+5 V Encoder
	22	22
	0 V	0 V Encoder
	23	23
	N.C.	Encoder Phase /A
	24	24
	N.C.	Encoder Phase /B
	25	25
	N.C.	N.C.

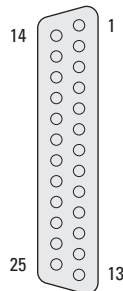

¹⁾ Pin #13 of SUB-D25M is reserved for internal logic for Newport controller.

6.0 Connection to Newport Controllers

6.1 Warnings on Controllers

Controllers are intended for use by qualified personnel who recognize shock hazards and are familiar with safety precautions required to avoid possible injury. Read the controller user's manual carefully before operating the instrument and pay attention to all written warnings and cautions.

WARNING

Disconnect the power plug under the following circumstances:

- If the power cord or any attached cables are frayed or damaged in any way.
- If the power plug is damaged in any way.
- If the unit is exposed to rain, excessive moisture, or liquids are spilled on the unit.
- If the unit has been dropped or the case is damaged.
- If you suspect service or repair is required.
- Whenever you clean the electronics unit.

CAUTION

To protect the unit from damage, be sure to:

- Keep all air vents free of dirt and dust.
- Keep all liquids away from the unit.
- Do not expose the unit to excessive moisture (85% humidity).
- Read this manual before using the unit for the first time.



WARNING

All attachment plug receptacles in the vicinity of this unit are to be of the grounding type and properly polarized.

Contact your electrician to check your receptacles.

WARNING

This product is equipped with a 3-wire grounding type plug.

Any interruption of the grounding connection can create an electric shock hazard.

If you are unable to insert the plug into your wall plug receptacle, contact your electrician to perform the necessary alterations to ensure that the green (green-yellow) wire is attached to earth ground.

WARNING

This product operates with voltages that can be lethal.

Pushing objects of any kind into cabinet slots or holes, or spilling any liquid on the product, may touch hazardous voltage points or short out parts.

6.2 Connection

On each actuator is represented a label which indicates its name and its serial number.



WARNING

Always turn the controller's power OFF before connecting to an actuator.

Actuators may be connected to the rear panel motor connectors any time prior to power-up with the supplied cable assemblies.

NOTE



These actuators are **ESP compatible**. **Enhanced System Performance** is Newport's exclusive technology that enables Newport ESP motion controllers to recognize the connected Newport ESP stage and upload the stage parameters. This ensures that the user can operate the motion system quickly and safely.

6.3 Cables

TRA-PP and TRA-CC are delivered equipped with a 3-meter cable, the TRA-PPV6 actuators are delivered with a 1.5-meter cable.

These cables are equipped with a SUB-D25M connector so they can be directly connected to our controllers/drivers.

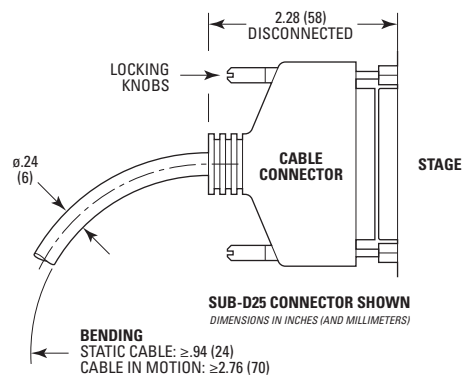

WARNING

This cable is shielded correctly. For a correct operation, make sure to lock connectors (ground continuity provided by the cable).



WARNING

Keep the motor cables at a safe distance from other electrical cables in your environment to avoid potential cross talk.

7.0 Connection to Non-Newport Electronics

7.1 Connections

WARNING

Newport is not responsible for malfunction or damage to a TRA actuator when it is used with non-Newport controllers.

WARNING

Newport guarantees “ C ” compliance of the TRA actuators only if they are used with Newport cables and controllers.

Nevertheless, the figure below shows the wiring when a TRA actuator is used with non-Newport controllers.

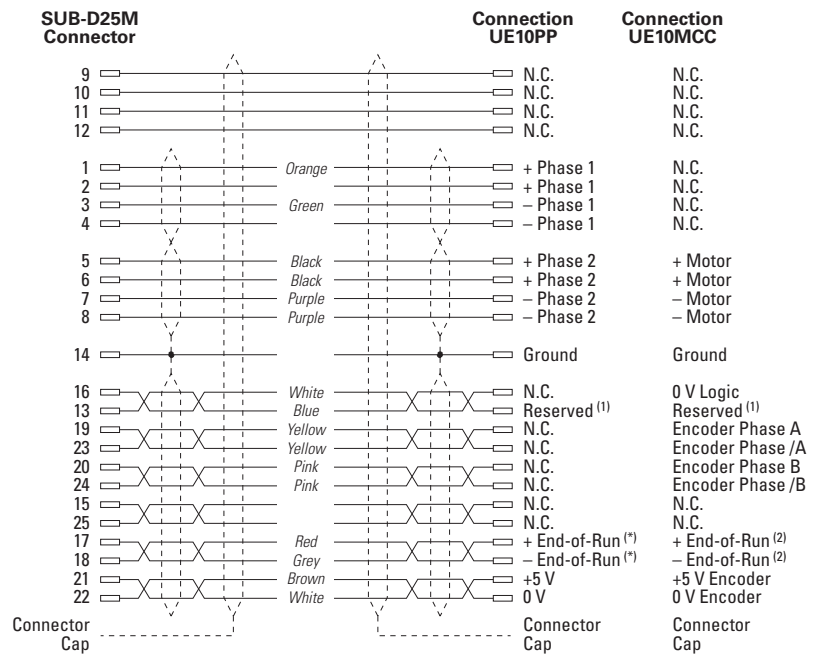

⁽¹⁾ Pin #13 of Newport Sub-D25M is reserved for internal logic for Newport controller.

⁽²⁾ Open collector type with a 5.6 V protective Zener diode.

For connection to non-Newport electronics, pin #17 and #18 End-of-Runs must be connected to +5 V with a pull-up resistor. For some non-Newport controllers, the +5 V output signal may be pulled up internally.

When a TRA actuator is used with non-Newport controllers using the SUB-D25M connector provided, pin #13 must be connected to +5 V with a pull-up resistor.

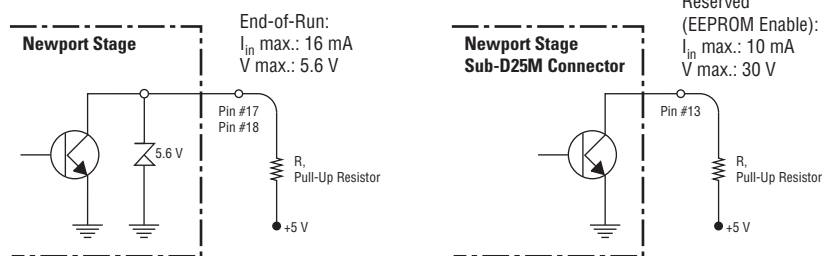

“Encoder” are “differential pair” (type RS-422) type output signals. Using these signals permits a high immunity to noise. Emission circuits generally used by Newport are 26LS31 or MC3487. Reception circuits to use are 26LS32 or MC3486.

8.0 Dimensions

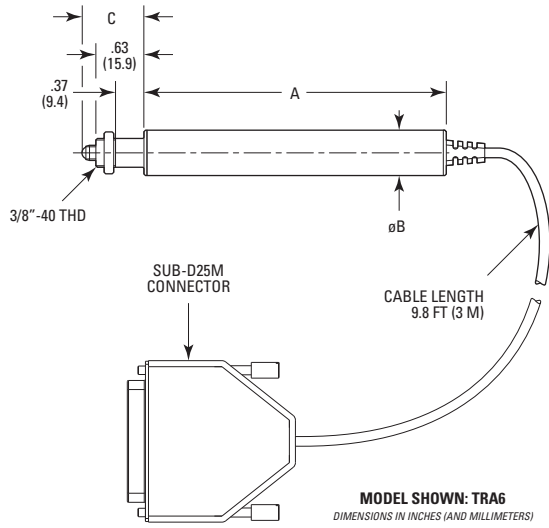

	A	B	C
TRA6	3.94 (100)	.59 (15)	.81 ⁺²⁴ ₀ (20.5 ⁺⁶ ₀)
TRA12	4.45 (113)	.59 (15)	.66 ⁺⁴⁹ ₀ (16.8 ^{+12.5} ₀)
TRA25	4.72 (120)	.71 (18)	.66 ⁺³⁸ ₀ (16.8 ^{+9.75} ₀)

9.0 Adapters for Opto-Mechanics



These adapters are designed to allow the TRA actuators to be used with opto-mechanical components with M12 x 0.5 threads. They must be to ordered separately.

ADAPT-TRA Adapter for TRA6 and TRA12 actuators

ADAPT-TRA25 Adapter for TRA25 actuators

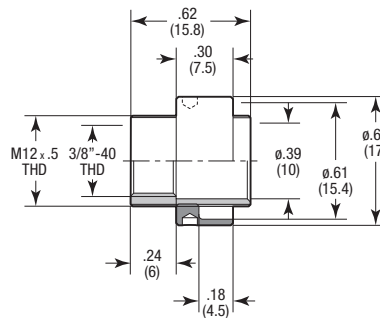

ADAPT-TRA

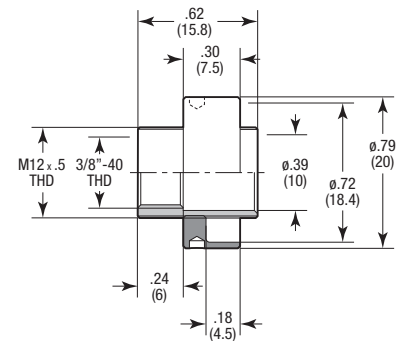

ADAPT-TRA25

10.0 Maintenance

RECOMMENDATION

It is recommended to contact our After Sales Service which will know to define the appropriate maintenance for your application.

10.1 Maintenance

The TRA actuator requires no particular maintenance. Nevertheless, this is a precision mechanical device that must be kept and operated with caution.

PRECAUTIONS

The TRA actuator must be used or stocked in a clean environment, without dust, humidity, solvents or other substances.

RECOMMENDATION

The actuator is guaranteed for 100 hours accumulated using. It is the lifetime limit.

It is recommended to return your actuator to Newport's After Sales Service after every 18 months of use for lubrication and maintenance.

If your TRA actuator is mounted on a workstation and cannot be easily removed, please contact Newport's After Sales Service for further instructions.

10.2 Repair

CAUTION



Never attempt to disassemble a component of the actuator that has not been covered in this manual.

To disassemble a non specified component can cause a malfunction of the stage.

If you observe a malfunction in your actuator, please contact us immediately to arrange for a repair.



CAUTION

Any attempt to disassemble or repair an actuator without prior authorization will void your warranty.

10.3 Calibration



CAUTION

It is recommended to return your TRA actuator to Newport after every 18 months for recalibration to its original specifications.

Service Form

Your Local Representative

Tel.: _____

Fax: _____

Name: _____

Company: _____

Address: _____

Country: _____

P.O. Number: _____

Return authorization #: _____

(Please obtain prior to return of item)

Date: _____

Phone Number: _____

Fax Number: _____

Item(s) Being Returned:

Model #: _____

Serial #: _____

Description: _____

Reasons of return of goods (please list any specific problems): _____

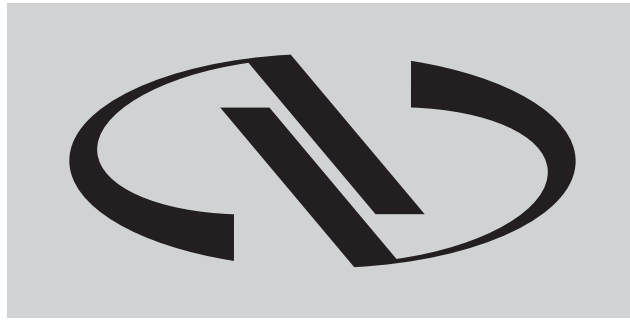

Newport®

Experience | Solutions

**Visit Newport Online at:
www.newport.com**

North America & Asia

Newport Corporation
1791 Deere Ave.
Irvine, CA 92606, USA

Sales

Tel.: (800) 222-6440
e-mail: sales@newport.com

Technical Support

Tel.: (800) 222-6440
e-mail: tech@newport.com

Service, RMAs & Returns

Tel.: (800) 222-6440
e-mail: service@newport.com

Europe

MICRO-CONTROLE Spectra-Physics S.A.S
9, rue du Bois Sauvage
91055 Évry CEDEX
France

Sales & Technical Support

Tel.: +33 (0)1.60.91.68.68
e-mail: france@newport.com

Service & Returns

Tel.: +33 (0)2.38.40.51.55