

Model TLB-7100 Vantage™ Laser System



User's Manual

 **New Focus™**
A Newport Corporation Brand

EU Declaration of Conformity

We declare that the accompanying product, identified with the **CE** mark, complies with requirements of the Electromagnetic Compatibility Directive, 2004/108/EC and the Low Voltage Directive 2006/95/EC.

Model Numbers: TLB-7100 series

Year **CE mark affixed: 2013**

Type of Equipment: Electrical equipment for measurement, control and laboratory use in industrial locations.

Manufacturer: Newport Corporation

1791 Deere Avenue
Irvine, CA 92606

Standards Applied:

Compliance was demonstrated to the following standards to the extent applicable:

BS EN61326-1: 2013 “Electrical equipment for measurement, control and laboratory use – EMC requirements” for use in a controlled electromagnetic environment.

This equipment meets the CISPR 11:2009+A1 Class A Group 1 radiated and conducted emission limits.

BS EN 61010-1:2010, “Safety requirements for electrical equipment for measurement, control and laboratory use”.



Mark Carroll
Sr. Director, Instruments Business
Newport Corporation
1791 Deere Ave, Irvine, CA92606 USA

Warranty

New Focus warrants that this product will be free from defects in material and workmanship and will comply with the New Focus' published specifications at the time of sale for a period of one year from date of shipment. If found to be defective during the warranty period, the product will either be repaired or replaced at New Focus' option.

To exercise this warranty, write or call your local Newport office or representative, or contact Newport headquarters in Irvine, California. You will be given prompt assistance and return instructions. Send the product, freight prepaid, to the indicated service facility. Repairs will be made and the instrument returned freight prepaid. Repaired products are warranted for the remainder of the original warranty period or 90 days, whichever occurs first.

Limitation of Warranty

The above warranties do not apply to products, which have been repaired or modified without Newport's written approval, or products subjected to unusual physical, thermal or electrical stress, improper installation, misuse, abuse, accident or negligence in use, storage, transportation or handling. This warranty also does not apply to fuses, batteries, or damage from battery leakage.

THIS WARRANTY IS IN LIEU OF ALL OTHER WARRANTIES, EXPRESSED OR IMPLIED, INCLUDING ANY IMPLIED WARRANTY OF MERCHANTABILITY OR FITNESS FOR A PARTICULAR USE. NEW FOCUS SHALL NOT BE LIABLE FOR ANY INDIRECT, SPECIAL, OR CONSEQUENTIAL DAMAGES RESULTING FROM THE PURCHASE OR USE OF ITS PRODUCTS.

First printing 2013

© 2013 by New Focus, Santa Clara, CA. All rights reserved. No part of this manual may be reproduced or copied without the prior written approval of New Focus.

This manual has been provided for information only and product specifications are subject to change without notice. Any change will be reflected in future printings.

New Focus
3635 Peterson Way
Santa Clara, CA, 95054
USA

Part No. 90059201 Rev A

Confidentiality & Proprietary Rights

Reservation of Title

The New Focus programs and all materials furnished or produced in connection with them ("Related Materials") contain trade secrets of New Focus and are for use only in the manner expressly permitted. New Focus claims and reserves all rights and benefits afforded under law in the Programs provided by New Focus.

New Focus shall retain full ownership of Intellectual Property Rights in and to all development, process, align or assembly technologies developed and other derivative work that may be developed by New Focus. Customer shall not challenge, or cause any third party to challenge the rights of New Focus.

Preservation of Secrecy and Confidentiality and Restrictions to Access

Customer shall protect the New Focus Programs and Related Materials as trade secrets of New Focus, and shall devote its best efforts to ensure that all its personnel protect the New Focus Programs as trade secrets of New Focus. Customer shall not at any time disclose New Focus's trade secrets to any other person, firm, organization, or employee that does not need (consistent with Customer's right of use hereunder) to obtain access to the New Focus Programs and Related Materials. These restrictions shall not apply to information (1) generally known to the public or obtainable from public sources; (2) readily apparent from the keyboard operations, visual display, or output reports of the Programs; 3) previously in the possession of Customer or subsequently developed or acquired without reliance on the New Focus Programs; or (4) approved by New Focus for release without restriction.

Trademarks

The New Focus logo and name are registered trademarks of Newport Corporation in Mexico, Israel, Singapore, European Union, Taiwan, Hong Kong, China, Japan, Korea, Canada, Australia, and the United States.

Service Information

This section contains information regarding factory service for the source. The user should not attempt any maintenance or service of the system or optional equipment beyond the procedures outlined in this manual. Any problem that cannot be resolved should be referred to New Focus.

Technical Support Contacts

North America

New Focus

3635 Peterson Way, Santa Clara, CA 95054
Telephone: (866) 683-6287
Telephone: (408) 919-1500

Europe

Newport/MICRO-CONTROLE S.A.

Zone Industrielle
45340 Beaune la Rolande, FRANCE
Telephone: (33) 02 38 40 51 56

Asia

Newport Opto-Electronics Technologies

中国 上海市 爱都路 253号 第3号楼 3层
C部位, 邮编 200131
253 Aidu Road, Bld #3, Flr 3, Sec C,
Shanghai 200131, China
Telephone: +86-21-5046 2300
Fax: +86-21-5046 2323

Newport Corporation Calling Procedure

If there are any defects in material or workmanship or a failure to meet specifications, promptly notify Newport's Returns Department by calling 1-800-222-6440 or by visiting our website at www.newport.com/returns within the warranty period to obtain a **Return Material Authorization Number (RMA#)**. Return the product to Newport Corporation, freight prepaid, clearly marked with the RMA# and we will either repair or replace it at our discretion. Newport is not responsible for damage occurring in transit and is not obligated to accept products returned without an RMA#.

E-mail: rma.service@newport.com

When calling Newport Corporation, please provide the customer care representative with the following information:

- Your Contact Information
- Serial number or original order number
- Description of problem (i.e., hardware or software)

To help our Technical Support Representatives diagnose your problem, please note the following conditions:

- Is the system used for manufacturing or research and development?
- What was the state of the system right before the problem?
- Have you seen this problem before? If so, how often?
- Can the system continue to operate with this problem? Or is the system non-operational?
- Can you identify anything that was different before this problem occurred?

Table of Contents

i

EU Declaration of Conformity.....	ii
Warranty.....	iii
Technical Support Contacts	v
Table of Contents	vi
List of Figures	ix
List of Tables.....	ix

1 Safety Precautions 11

1.1 Definitions and Symbols	11
1.1.1 General Warning or Caution	11
1.1.2 Electric Shock.....	11
1.1.3 European Union CE Mark	11
1.1.4 Alternating Voltage Symbol.....	12
1.1.5 On	12
1.1.6 Off.....	12
1.1.7 Fuses	12
1.1.8 USB	13
1.1.9 Frame or Chassis	13
1.1.10 Waste Electrical and Electronic Equipment (WEEE)	13
1.1.11 Control of Hazardous Substances.....	14
1.1.12 Laser Radiation Warning Label.....	14
1.1.13 Avoid Direct Eye Exposure Label.....	14
1.1.14 Laser Aperture Label.....	15
1.2 Warnings and Cautions.....	15
1.2.1 General Warnings	15
1.2.2 General Cautions	16
1.2.3 Summary of Warnings and Cautions.....	16
1.3 Location of Labels and Warnings.....	20
1.3.1 TLB-6800-LN Rear Panel	20
1.3.2 TLB-7100 Vantage Laser Head.....	21

2 General Information 23

2.1 Introduction	23
2.1.1 Key Product Features:	23
2.1.2 Instrument Features	24
2.2 Input Power	24
2.3 Specifications	25
2.3.1 Tunable Diode Laser	25
2.3.2 System Specifications.....	25
2.3.3 General Specifications.....	26

3	Getting Started	27
3.1	Unpacking and Handling	27
3.2	Inspection for Damage	27
3.3	Parts List	28
3.4	Choosing and Preparing a Suitable Work Surface	28
3.5	Electrical Requirements.....	28
3.6	Power Supplies	29
3.7	Quick Start.....	31
3.7.1	Connecting the Laser Components.....	31
3.7.2	Grounding and Powering the Laser System	31
3.7.3	Turning the Laser ON.....	32
3.7.4	Turning the Laser OFF	32
3.7.5	Software Installation.....	32
4	System Operation	33
4.1	Description of Laser System	33
4.1.1	Controller.....	33
4.1.2	Laser Head.....	35
4.2	Using the Front Panel	36
4.2.1	Setting the Laser Current.....	37
4.2.2	Fine Wavelength Control	37
4.2.3	Function Generator	37
4.2.4	Feed Forward.....	38
4.2.5	Laser Current Limit Protection.....	38
4.3	Menu Section.....	39
4.3.1	Control Knobs	39
4.3.2	Enter	39
4.3.3	Display Elements.....	39
4.3.4	Menu Selection	40
4.3.5	Title Screen.....	40
4.3.6	Instrument Firmware Version Screen.....	40
4.3.7	Laser Head Information Screen	40
4.3.8	Main Screen.....	41
4.3.9	Parameter Setup Screens	41
4.4	Rear Panel.....	43
4.4.1	USB Interface	43
4.4.2	RS-232 Serial Interface	43
4.4.3	Chassis GND	44
4.4.4	AC Power Cord	44
4.4.5	Fuses	44
4.4.6	Frequency Modulation Input	45
4.4.7	Current Modulation Input.....	45
4.4.8	High-Speed Current Modulation	46
4.4.9	Auxiliary Input	46

5	Computer Interfacing	47
5.1	Introduction	47
5.2	Computer Interface Terminology	47
5.2.1	<...> Delimiting Punctuation	47
5.2.2	<CR> Carriage Return.....	47
5.2.3	<LF> Line Feed.....	47
5.2.4	(;) Semicolons.....	48
5.2.5	Command Termination.....	48
5.2.6	Response Termination	48
5.3	Controller Operation Mode	48
5.4	USB Communication.....	48
5.5	RS-232 Communication	48
5.6	Commands Summary	49
5.6.1	Conventions.....	49
5.6.2	Types of Commands.....	50
5.6.3	Index of Commands	51
6	Principles of Operation	75
6.1	Theory of Design	75
6.1.1	References	76
7	Tips and Techniques	77
7.1	Introduction	77
7.2	Grounding a Laser Head.....	77
8	Maintenance and Service	79
8.1	Enclosure Cleaning.....	79
8.2	Technical Support.....	79
8.3	Obtaining Service	80
8.4	Warranty	80
8.5	Service Form	81
9	Appendix A – Error Messages	83
9.1	Introduction	83
9.2	Error Description	83

List of Figures

Figure 1	General Warning or Caution Symbol	11
Figure 2	Electrical Shock Symbol	11
Figure 3	CE Mark	11
Figure 4	Alternating Voltage Symbol.....	12
Figure 5	On Symbol.....	12
Figure 6	Off Symbol	12
Figure 7	Fuse Symbol	12
Figure 8	USB Symbol.....	13
Figure 9	Frame or Chassis Terminal Symbol	13
Figure 10	WEEE Directive Symbol.....	13
Figure 11	RoHS Compliant Symbol.....	14
Figure 12	Laser Radiation Warning Label.....	14
Figure 13	Avoid direct eye exposure label	14
Figure 14	Laser Aperture Label	15
Figure 15	Rear Panel Labels and Warnings.....	20
Figure 16	TLB-7100Vantage Laser Head(top and rear view)	21
Figure 17	Controller Block Diagram	33
Figure 18	Laser Head Mechanical Schematic forTLB-7100 Series laser....	35
Figure 19	Front Panel Layout	36
Figure 20	A Sample Title Screen.....	40
Figure 21	A Sample Title Screen.....	40
Figure 22	A Sample Laser Head Information Screen.....	41
Figure 23	A Sample Main Screen.....	41
Figure 24	A Sample Params Setup Screen	41
Figure 25	Model 6800 Menu Structure.....	42
Figure 26	Rear Panel.....	43
Figure 27	Schematic of the Vantage laser cavity.....	75

List of Tables

Table 1	Voltage Selector Switch Settings and Fuse Ratings.....	30
---------	--	----

This page is intentionally left blank

1 Safety Precautions

1.1 Definitions and Symbols

The following terms and symbols are used in this documentation and appear on the Model TLB-6800-LN Controller and attached TLB-7100 Vantage™ Tunable Diode Laser Head where safety-related issues occur.

1.1.1 General Warning or Caution



Figure 1 *General Warning or Caution Symbol*

The Exclamation Symbol in the figure above appears on the product and in Warning and Caution tables throughout this document. This symbol designates that documentation needs to be consulted to determine the nature of a potential hazard, and any actions that have to be taken.

1.1.2 Electric Shock



Figure 2 *Electrical Shock Symbol*

The Electrical Shock Symbol in the figure above appears throughout this manual. This symbol indicates a hazard arising from dangerous voltage. Any mishandling could result in irreparable damage to the equipment, and personal injury or death.

1.1.3 European Union CE Mark



Figure 3 *CE Mark*

The presence of the CE Mark on New Focus-branded equipment means that this instrument has been designed, tested and certified compliant to all applicable European Union (CE) regulations and recommendations.

1.1.4 Alternating Voltage Symbol



Figure 4 *Alternating Voltage Symbol*

This international symbol implies an alternating voltage or current.

1.1.5 On



Figure 5 *On Symbol*

The symbol in the figure above represents a power switch position on the Model TLB-6800-LN Controller. This symbol represents a Power On condition.

1.1.6 Off



Figure 6 *Off Symbol*

The symbol in the figure above represents a power switch position on the Model TLB-6800-LN Controller. This symbol represents a Power Off condition.

1.1.7 Fuses

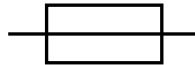

Figure 7 *Fuse Symbol*

The symbol in the figure above identifies the fuse location on the Model TLB-6800-LN Tunable Diode Laser.

1.1.8 USB



Figure 8 *USB Symbol*

The symbol in the figure above identifies the USB connector location on the Model TLB-6800-LN Controller.

1.1.9 Frame or Chassis

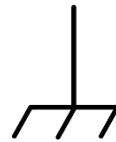

Figure 9 *Frame or Chassis Terminal Symbol*

The symbol in the figure above appears on the Model TLB-6800-LN Controller. This symbol identifies the frame or chassis terminal

1.1.10 Waste Electrical and Electronic Equipment (WEEE)



Figure 10 *WEEE Directive Symbol*

This symbol on the product or on its packaging indicates that this product must not be disposed with regular waste. Instead, it is the user responsibility to dispose of waste equipment according to the local laws. The separate collection and recycling of the waste equipment at the time of disposal will help to conserve natural resources and ensure that it is recycled in a manner that protects human health and the environment. For information about where the user can drop off the waste equipment for recycling, please contact your local New Focus representative.

1.1.11 Control of Hazardous Substances

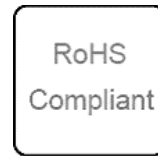

Figure 11 *RoHS Compliant Symbol*

This label indicates the products comply with the EU Directive 2002/95/EC that restricts the content of six hazardous chemicals.

1.1.12 Laser Radiation Warning Label



Figure 12 *Laser Radiation Warning Label*

This label indicates the presence of visible and invisible laser radiation as well as the wavelength range and maximum output power.

1.1.13 Avoid Direct Eye Exposure Label



Figure 13 *Avoid direct eye exposure label*

This label indicates the presence of laser radiation. Users are advised to avoid direct eye exposure.

1.1.14 Laser Aperture Label



Figure 14 *Laser Aperture Label*

This label indicates the location of the laser aperture.

1.2 Warnings and Cautions

The following are definitions of the Warnings, Cautions and Notes that are used throughout this manual to call your attention to important information regarding your safety, the safety and preservation of your equipment or an important tip.

	WARNING
	Situation has the potential to cause bodily harm or death.

	CAUTION
	Situation has the potential to cause damage to property or equipment.

NOTE

Additional information the user or operator should consider.

1.2.1 General Warnings

Observe these general warnings when operating or servicing this equipment:

- Heed all warnings on the unit and in the operating instructions.
- Do not use this equipment in or near water.
- This equipment is grounded through the grounding conductor of the power cord.

- Route power cords and other cables so that they are not likely to be damaged.
- Disconnect power before cleaning the equipment. Do not use liquid or aerosol cleaners; use only a damp lint-free cloth.
- Lockout all electrical power sources before servicing the equipment.
- To avoid fire hazard, use only the specified fuse(s) with the correct type number, voltage and current ratings as referenced in the appropriate locations in the service instructions or on the equipment. Only qualified service personnel should replace fuses.
- To avoid explosion, do not operate this equipment in an explosive atmosphere.
- Qualified service personnel should perform safety checks after any service.

1.2.2 General Cautions

Observe these cautions when operating this equipment:

- If this equipment is used in a manner not specified in this manual, the protection provided by this equipment may be impaired.
- To prevent damage to equipment when replacing fuses, locate and correct the problem that caused the fuse to blow before re-applying power.
- Do not block ventilation openings.
- Do not position this product in such a manner that would make it difficult to disconnect the power cord.
- Position the equipment so that access to the mains disconnect On/Off switch is readily available.
- Use only the specified replacement parts.
- Follow precautions for static sensitive devices when handling this equipment.
- This product should only be powered as described in the manual.
- There are no user-serviceable parts inside the Model TLB-6800-LN Controller.
- Adhere to good laser safety practices when using this equipment.

1.2.3 Summary of Warnings and Cautions

The following general warning and cautions are applicable to this instrument:

**WARNING**

Before operating the Model TLB-6800-LN Controller, please read and understand all of Section 1.

**WARNING**

Do not attempt to operate this equipment if there is evidence of shipping damage or you suspect the unit is damaged. Damaged equipment may present additional hazards to you. Contact New Focus technical support for advice before attempting to plug in and operate damaged equipment.

**WARNING**

To avoid electric shock, connect the instrument to properly earth-grounded, 3-prong receptacles only. Failure to observe this precaution can result in severe injury.

**WARNING**

Before cleaning the enclosure of the Model TLB-6800-LN Controller, or the enclosure of any attached Tunable Diode Laser head, the AC power cord must be disconnected from the wall socket.

**CAUTION**

There are no user serviceable parts inside the Model TLB-6800-LN and the associated Tunable Diode Laser head. Work performed by persons not authorized by New Focus will void the warranty. For instructions on obtaining warranty repair or service, please refer to Section 8.

**WARNING**

If this equipment is used in a manner not specified in this manual, the protection provided by this equipment may be impaired.

**WARNING**

While the Model TLB-6800-LN Controller's front panel key switch turns power OFF to the internal electronics, it should not be depended upon to fully disconnect the unit from MAINS power. Disconnect the power cord to fully isolate the Model TLB-6800-LN from MAINS power. Do not position the TLB-6800-LN Controller so that it is difficult to disconnect the power cord.

**WARNING**

The rear panel LASER CONTROL connector may have voltages as high as 140 VDC between various connector pins. Do not power up the Model TLB-6800-LN without a laser head connected.

**WARNING**

Do not attempt to power up the controller if the cable between the controller and the laser head is damaged.

**WARNING**

Use only New Focus Model Number TLB-6700-01 cable, or New Focus approved alternative, to connect the TLB-6800-LN controller to a TLB-7100 (Vantage) series laser head.

**WARNING**

Do not disconnect the cable between the Model TLB-6800-LN Controller and the attached laser head while the Model TLB-6800-LN Controller is powered up.

**WARNING**

Secure the connector screw locks at both ends of the cable between the Model TLB-6800-LN and the attached laser head.

	<p>The Model TLB-6800-LN Controller is intended for use in an industrial laboratory environment. Use of this product in other environments, such as residential, may result in electromagnetic compatibility difficulties due to conducted as well as radiated disturbances.</p>
---	--

	<p>The Model TLB-7100 Laser System is designed to operate in a controlled electromagnetic environment; i.e., where R.F. transmitters, such as mobile telephones, may not be used in close proximity.</p>
---	--

	<p style="text-align: center;">WARNING</p> <p>Use of controls or adjustments or performance procedures other than those specified herein may result in hazardous radiation exposure.</p>
---	---

	<p style="text-align: center;">WARNING</p> <p>The Model TLB-6800-LN controller is intended for use ONLY with New Focus specified laser head modules. DO NOT ATTEMPT TO USE THE CONTROLLER WITH UNAPPROVED OTHER DEVICES INCLUDING NEW FOCUS VELOCITY (TLB-6700-SERIES) LASER HEADS.</p>
---	--

	<p style="text-align: center;">WARNING</p> <p>The TLB-7100-series laser heads are intended for use ONLY with a New Focus TLB-6800-LN controller DO NOT ATTEMPT TO USE THE LASER HEAD WITH UNAPPROVED OTHER DEVICES INCLUDING THE NEW FOCUS VELOCITY (TLB-6700-LN AND -XP) CONTROLLERS.</p>
---	---

1.3 Location of Labels and Warnings

1.3.1 TLB-6800-LN Rear Panel

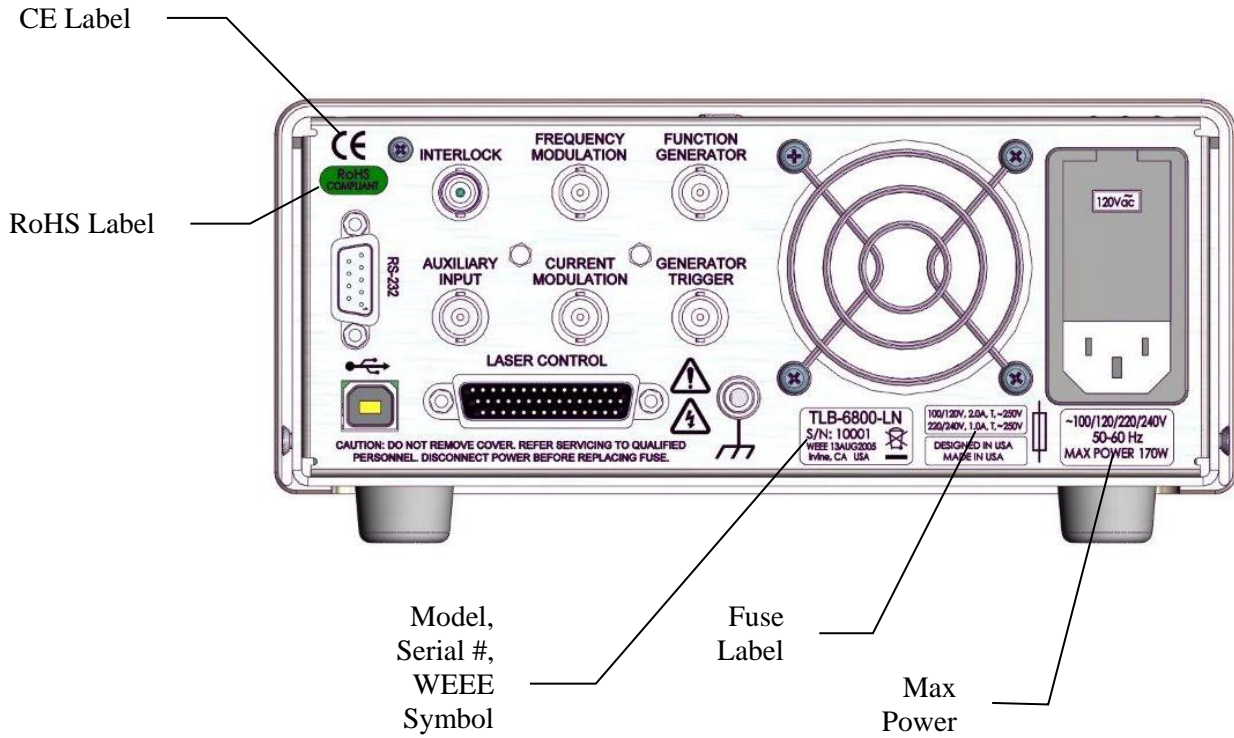

Figure 15 Rear Panel Labels and Warnings

1.3.2 TLB-7100 Vantage Laser Head

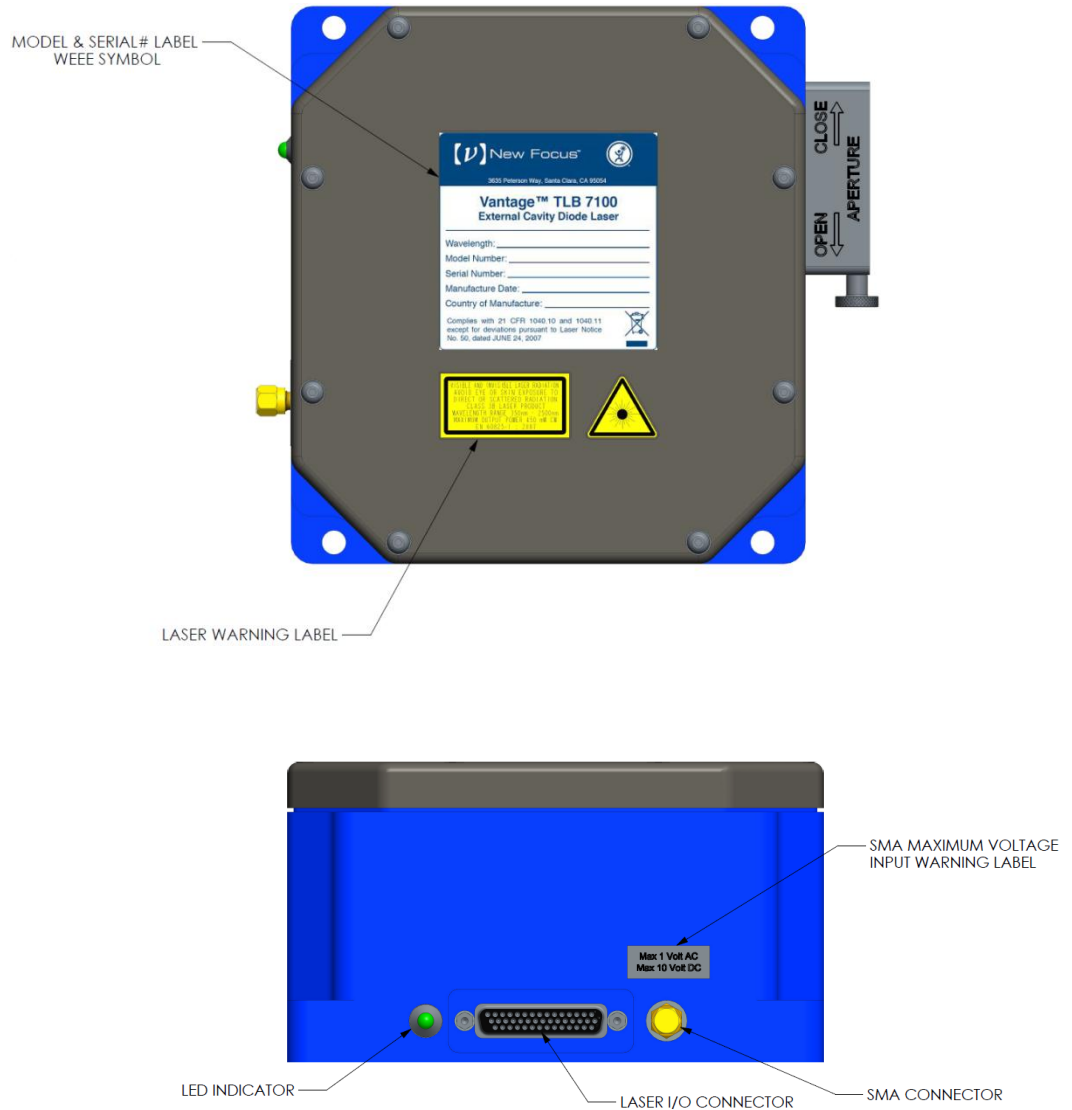

Figure 16 TLB-7100Vantage Laser Head(top and rear view)

This page is intentionally left blank

2 General Information

2.1 Introduction

The New Focus TLB-7100 Vantage Tunable External Cavity Diode Laser is a stable, narrow-linewidth source of tunable light. The Model TLB-7100 series laser head is compatible with the TLB-6800-LN Controller. The laser can be operated manually from the front panel or remotely using computer control.

The TLB-7100 series laser incorporates a simple, stable mechanical design with a minimal number of optical components. Low-noise analog circuits precisely set critical operating parameters, such as diode temperature and current. Digital control facilitates remote operation and computer interfacing.

The TLB-7100 is a modular system. The same TLB-6800-LN controller will work with any 7100 series laser head. The control unit works in both manual and remotely programmed modes and is compatible with USB and RS232 interfaces.

The TLB-6800-LN's front panel multi-line display shows important operating parameters including laser diode current and PZT voltage. Inputs are available on the TLB-6800-LN rear panel and the TLB-7100 Vantage laser head for low-speed and high-speed diode current modulation.

2.1.1 Key Product Features:

Versatile tuning performance

- Fine-tuning with the PZT at 0.1-GHz resolution
- Smooth, linear, mode hop-free PZT sweeps
- Manual and coarse tuning

Low noise & narrow linewidths

- < 300-kHz linewidths
- > 30-dB side-mode suppression ratios

Flexible configurations

- Wavelengths from 395 nm to 2200 nm
- Current modulation and FM modulation

Protections

- Laser current limit and fault protection
- Ability to turn off the LED current if a fault is detected with the TEC

Over-temperature protection

Plug & play

- USB and RS232 remote interface
- Laser head recognition

2.1.2 Instrument Features**Intuitive Controls and VFD Display**

Improved data presentation and system control are achieved using a large 2 row by 20 character vacuum florescent display (VFD), dual ergonomic adjustment knobs, and thoughtfully arranged pushbuttons, some with integral LEDs.

The VFD clearly shows system configuration and status with wide viewing angle. A myriad of precise yet fast adjustments of key parameters (e.g., output current) and mode changes are possible with the dual knob controls, menu and dedicated function pushbuttons.

The unique dual knob arrangement makes it possible to simultaneously and finely adjust two key parameter settings, such as output current and piezo voltage – in real-time.

2.2 Input Power

The Model TLB-6800-LN can be configured to operate on 100, 120, 220, or 240 volt AC power. See Section 3.6 for information on how to configure the Model TLB-6800-LN for operation on your country-specific AC voltage.

2.3 Specifications

2.3.1 Tunable Diode Laser

Model Number	Wavelength Coverage Range, nm	Maximum Power, mW
TLB-7102-XX	350-500	450
TLB-7103-XX	500-600	450
TLB-7104-XX	600-700	450
TLB-7113-XX	700-800	450
TLB-7115-XX	800-1000	450
TLB-7121-XX	1000-1200	450
TLB-7125-XX	1200-1500	450
TLB-7128-XX	1500-2000	450
TLB-7132-XX	2000-3000	450
TLB-7135-XX	3000-5000	450

xxxx: denotes specific wavelength in the defined range

Beam Divergence	max 5 mrad
Maximum Beam Spot Size (at 60 cm from laser aperture)	max 3 mm

2.3.2 System Specifications

Specifications	Value	Comment
Linewidth	≤ 300 kHz	Integrated over 50 ms
Wavelength Stability	≤ 1 pm ≤ 5 pm	Over 1 hour Over 36 hours
Frequency Modulation Bandwidth (Internal Generator)	0.1 Hz - 100 Hz	100 GHz amplitude ³
Max Frequency Modulation Bandwidth	100 Hz 1.5 kHz	100 GHz amplitude ³ 20 GHz amplitude ³
Max Current Modulation Bandwidth	< 1 MHz	Through controller
Max Current Modulation Bandwidth	< 100 MHz	Directly to diode through laser head SMA

		port
Optical Output	Free-space	

2.3.3 General Specifications

Environmental Specifications	
Voltage Requirements	100/120/220/240 VAC, 50/60Hz
Power Requirements	MAX POWER = 170 Watts
Chassis Ground	4 mm banana jack
Size (H x W x D) [in. (mm)]	3.48 (88.4) x 14.0 (355.6) x 16.51 (419.4)
Mainframe Weight [lb (kg)]	17.9 (8.1)
Operating Temperature	10°C to 40°C (<90% humidity non-condensing)
Storage Temperature	0°C to + 50°C (<90% humidity non-condensing)
Relative Humidity, Storage	<90% humidity non-condensing
Altitude	<2000 meters (6550 feet)
Installation Category	II
Pollution Degree	2
Use Location	Indoor use only

The Model TLB-6800-LN Controller and TLB-7100 laser head were designed to operate in a controlled electromagnetic environment. While they will not be damaged by operation in an industrial electromagnetic environment, as defined in EN61316-1:2013, such operation may not yield optimal performance. For this reason, New Focus does not recommend operation of these devices in close proximity to mobile telephones, hand-held radio transmitters, and similar devices.

3 Getting Started

3.1 Unpacking and Handling

It is recommended that the Model TLB-6800-LN Controller and the TLB-7100 laser head be unpacked in a lab environment or work site. Unpack the system carefully; small parts are included with the instrument. Inspect the box carefully for loose parts. You are advised to save the packaging material in case you need to ship your equipment in the future.

3.2 Inspection for Damage

The Model TLB-6800-LN Controller and the associated laser head are carefully packaged at the factory to minimize the possibility of damage during shipping. Inspect the box for external signs of damage or mishandling. Inspect the contents for damage. If there is visible damage to the instrument upon receipt, inform the shipping company and New Focus immediately. Carefully open the box and save the shipping material for later use.



WARNING

Do not attempt to operate this equipment if there is evidence of shipping damage or you suspect the unit is damaged. Damaged equipment may present additional hazards to you. Contact New Focus technical support for advice before attempting to plug in and operate damaged equipment.



CAUTION

The user is advised to save the packaging material in case the unit has to be shipped to a different location. The packaging material is specially designed to protect the unit during shipping.

3.3 Parts List

The following is a list of parts included with the Model TLB-7100 system

1. TLB-6800-LN Controller and its accessory items.
2. TLB-6700-01 Cable
3. TLB-7100 Vantage laser head.

The following is a list of parts included with the Model TLB-6800-LN Controller:

1. USB Flash drive with Software Drivers and Utilities, User's Manual, Start Up Guide.
2. IEC320 AC line cord with a NEMA 5-15P
3. USB Cable for connecting the controller to a computer.
4. Spare fuses for 220 VAC, 230 VAC, and 240 VAC power.

If you are missing any parts or have questions about the parts you have received, please contact New Focus.

3.4 Choosing and Preparing a Suitable Work Surface

The Model TLB-6800-LN and the TLB-7100 laser head may be placed on any reasonably firm table or bench during operation.

3.5 Electrical Requirements

Before attempting to power up the unit for the first time, the following precautions must be followed:



WARNING

To avoid electric shock, connect the instrument to properly earth-grounded, 3-prong receptacles only. Failure to observe this precaution can result in severe injury.



WARNING

The TLB-6800-LN controller is supplied with a detachable power cord. Do not replace this cord with an inadequately rated cord.

- Have a qualified electrician verify the wall socket that will be used is properly polarized and properly grounded.

- Provide adequate distance between the Models TLB-6800-LN, and the laser head, and adjacent walls for ventilation purposes. Do not let any other equipment blow hot air towards the devices. Verify the correct rated fuses are installed according to the fuse marking on the rear panel. The unit has temperature sensors. If the unit overheats it will generate an error message and stop operation to protect itself, until the user takes the necessary steps to lower the temperature.

3.6 Power Supplies



WARNING

To avoid electric shock, the Model TLB-6800-LN must be configured for operation on your specific AC line voltage PRIOR TO CONNECTING THE POWER CORD TO THE AC MAINS. See the instructions above for information

AC power is supplied through the rear panel power entry module connector that provides in-line transient protection and RF filtering. The power entry module also contains the instrument's fuses and the voltage selection switch.

Prior to plugging in the AC line cord, the user MUST configure the Model TLB-6800-LN for operation on the available AC power. This is accomplished by setting the voltage selector switch on the AC power entry module AND verifying that the correct fuses are installed into the power entry module. Failure to do this can result in degraded instrument performance, damage to the Model TLB-6800-LN, and / or injury to the operator.

The voltage selector switch and the fuses are accessed by opening the power entry module using a flat-bladed screwdriver. Note that the AC line cord must be removed from the power entry module prior to attempting to open it. With the power entry module open, the voltage selector switch setting can be changed by removing the drum, rotating it to the desired setting, and reinstalling the drum. Do not attempt to rotate the drum, while it is inserted in the power entry module. You risk bending the power contacts and rendering the unit inoperable.

After correctly setting the voltage selection switch, the fuses installed in the power entry module should be checked for the correct value and, if not correct, changed.

Table 1, below, identifies the correct voltage selector switch setting and fuse ratings for several common AC power levels.

Input Power	Voltage Switch Setting	Fuses
100 VAC, 50 Hz	100	2A, 250VAC, Slo-Blo
120 VAC, 60 Hz	120	2A, 250VAC, Slo-Blo
220 VAC, 50 Hz	230	1A, 250VAC, Slo-Blo
230 VAC, 50 Hz	230	1A, 250VAC, Slo-Blo
240 VAC, 60 Hz	240	1A, 250VAC, Slo-Blo

Table 1 *Voltage Selector Switch Settings and Fuse Ratings*

WARNING

With the power entry module open, the voltage selector switch setting can be changed by removing the drum, rotating it to the desired setting, and reinstalling the drum. Do not attempt to rotate the drum, while it is inserted in the power entry module. Failure to observe this procedure will result in equipment damage.



WARNING

To avoid electric shock, connect the instrument to properly earth-grounded receptacles only. Failure to observe these precautions can result in fire, severe injury or death.



WARNING

To avoid electric shock, the appropriate fuses for the AC input power voltage must be installed in the instrument. Only qualified service personnel should replace fuses. Failure to observe these precautions can result in fire, severe injury or death.

3.7 Quick Start

This section outlines the basic steps needed to start using your External Cavity Tunable Diode Laser, including a brief setup and getting started guide. It assumes that earlier sections regarding safety and AC input power settings have been read. For more detailed information on how to operate the instrument, refer to Chapter 4 System Operation.



WARNING

The safety of any system incorporating the equipment is the responsibility of the assembler of the system.

3.7.1 Connecting the Laser Components

Connect the Model TLB-6800-LN Controller to the TLB-7100 laser head using the TLB-6700-01 cable. Secure the screw locks on the connectors at both ends of the cable.



WARNING

Use only New Focus Model Number TLB-6700-01 cable, or New Focus approved alternative, to connect the TLB-6800-LN controller to a TLB-7100 (Vantage) series laser head.



WARNING

Do not disconnect the cable between the Model TLB-6800-LN Controller and the laser head while the Model TLB-6800-LN Controller is powered up.



WARNING

Secure the connector screwlocks at both ends of the cable between the Model TLB-6800-LN and the TLB-7100 laser head.

3.7.2 Grounding and Powering the Laser System

Verify that the line voltage setting on the rear of the Model TLB-6800-LN Controller matches your MAINS power. Verify that the proper fuses are installed. See Section 3.6, above, for details.

Connect the binding post on the rear of the chassis to earth ground. While the protective ground wire within the MAINS power cord, when connected to a properly earth-grounded receptacle using the supplied power cord, will provide adequate safety protection, the system noise performance may be improved if this additional connection is made.



WARNING

To avoid electric shock, connect the instrument to properly earth-grounded receptacles only. Failure to observe these precautions can result in fire, severe injury or death.



WARNING

To avoid electric shock, the appropriate fuses for the AC input power voltage must be installed in the instrument. Only qualified service personnel should replace fuses. Failure to observe these precautions can result in fire, severe injury or death.

3.7.3 Turning the Laser ON

Turn lockout keyswitch to “I” position to power on the unit.

Turn the knob control to set the desired Current setpoint.

Press Laser Power button. The LED in the button will flash for 6 seconds and then stay ON. The TLB-7100 Vantage laser head local LED will also stay ON after 6 seconds. The actual laser diode current will quickly ramp up to the specified setpoint.

3.7.4 Turning the Laser OFF

To minimize the risk of power surges damaging the laser diode and to preserve the lifetime of the diode, push the Laser Power button to turn OFF the laser when it is not in use (the LED on the button will turn off) and before shutting down the system. Turn the front panel keyswitch to “O” position to shut down the entire system.

3.7.5 Software Installation

For instructions on how to install the software provided with the controller, please refer to TLB-6800 ReadMe.pdf file. You need to have a PDF reader to view its contents.

4 System Operation

4.1 Description of Laser System

4.1.1 Controller

The job of the controller is to provide a stable, low-noise power source for the diode laser, set the temperature in the laser head, and provide readouts of all relevant laser parameters. Conceptually, the circuitry inside the controller is built in two layers: analog and digital. The analog layer incorporates low-noise design for temperature and current control. The digital layer includes all the readouts and circuits to set various operating point parameters. This layer acts as an interface between the user (or the user's computer) and the analog layer.

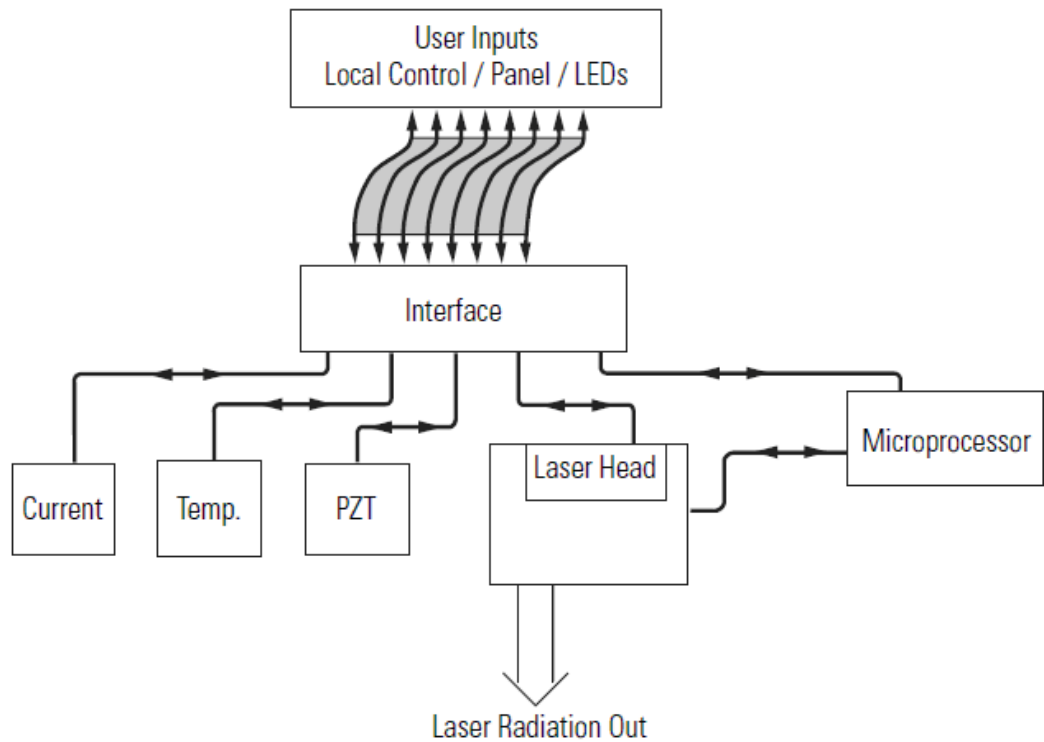

Figure 17 Controller Block Diagram

The analog layer consists of four modules: current control, temperature control, and piezoelectric transducer (PZT) driver (which controls wavelength fine-tuning)

The digital layer includes a Digital Signal Processor (DSP) and user interface circuitry. There is a digital circuit in the laser head that contains information specific to each laser head such as the optimal temperature, current settings and the laser head serial number.

The current driver is a low-noise, analog, DC-current supply which provides up to hundreds of mA of current to the laser diode. The AC ripple in the output is sub μA RMS. If desired, the current supply can be modulated at up to 1 MHz through a BNC connector on the rear panel of the controller. For proper operation, use only with a cable shorter than three meters.

The temperature driver controls the laser temperature by supplying current to thermoelectric (Peltier) elements in the laser head. A DSP is used to perform PID feedback control for each element. In this way, the laser temperature and the surrounding environment are stabilized to within plus or minus 10 millikelvin.

The PZT driver supplies 0–120 Volts DC to a piezoelectric fine-tuning element in the laser head. By using the PZT system you can tune the wavelength smoothly with sub-angstrom precision.

The DSP based digital board controls all of the other modules, runs the digital displays, and provides USB interfacing capability. It also communicates with the circuit board in the laser head to determine what kind of laser head it is.

4.1.2 Laser Head

The laser head embodies a simple, ultra-stable design which is shown below. Everything is mounted on a solid metal base and enclosed in a sealed package. You will never need to open the laser head to operate the laser. Unauthorized opening of the laser head will void the warranty. Contact New Focus for user servicing instructions.

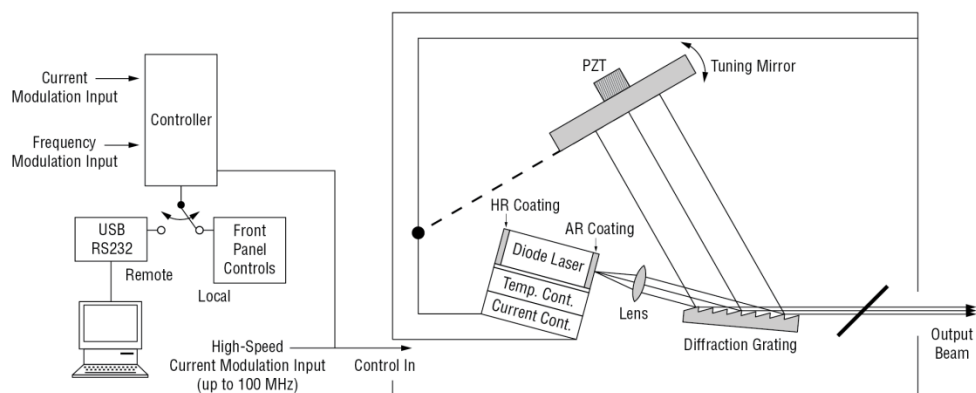

Figure 18 *Laser Head Mechanical Schematic for TLB-7100 Series laser*

In this design, a diode laser is used as the gain medium. One end of the diode laser has a high reflectivity coating, which acts as an end mirror of the external-cavity. In most Vantage models the other end of the diode has an antireflection coating.

The diode laser is bonded to a temperature sensor and a thermoelectric cooling block which maintains a highly stable diode temperature.

The laser beam radiating from the diode is collimated by a lens before striking a high-quality diffraction grating. The diffraction grating is mounted on a tuning arm and precisely aligned at New Focus. The position of this tuning arm determines the operating wavelength of the laser. The arm is moved by a piezoelectric transducer (PZT) for micron scale movements, which correspond to sub-angstrom wavelength tuning precision. From the diffraction grating, a fraction of the beam is directed to the output mirror.

An SMA connector is available on the outside of the head enclosure for high-speed current modulation. The use of this feature is described in Section 4.4 Rear Panel.

Finally, the laser head records how many hours the diode laser has operated. A new laser head will typically show 100-150 hours due to factory burn-in.

	WARNING Before powering up or operating the Model TLB-6800-LN Controller, please read and understand all of Section 1.
---	--

4.2 Using the Front Panel

The front panel of the Model TLB-6800-LN Tunable Diode Laser Controller is designed for easy operation. It has various distinct areas, each with a specific set of related functions, and control knobs, as shown in Figure 19 below.



Figure 19 *Front Panel Layout*

Make sure the controller is plugged into a wall socket and your laser head cable is plugged into the back of the controller. Point the laser head in a safe direction, and check that the AC power input connector is configured for the correct line voltage.

Turn on the AC power using the front panel keyswitch. The laser-head serial numbers, optimum diode parameter settings and other pertinent operating information stored in an EEPROM in the laser head are uploaded to the controller. The alphanumeric display will show the model number, and the controller software revision number. After a few seconds, the display will become active.

About 30 minutes of warm-up time is recommended for best performance.

The keyswitch is the “on-off” for the whole unit including the laser head. The Laser Power button controls the laser output. When you push the Laser Power button, it flashes for a 6-second safety delay (default value) and then lights up to indicate that current is flowing through the diode laser in the laser head unit. This allows you to set up all the desired operating parameters with the AC Power on, but while the laser is not generating light.

4.2.1 Setting the Laser Current

Press the Current/Voltage button to display the laser current and the piezo voltage setpoints.

To set the desired Current level turn the knob control that is positioned below the Current reading on the display screen. The New Focus Vantage Tunable Diode Laser is designed to run on a single longitudinal mode. The system is set so that the maximum drive current is below the threshold of multimode operation. It is possible for the end-user to reset the maximum drive current limit via a remote command. This is only recommended when the end-user installs a new diode.

The Current can be changed only when its Knob Enable button is pressed and the button LED is lit. To disable the current set knob press the Knob Enable button again.

4.2.2 Fine Wavelength Control

The Piezo Voltage is used for fine (mHz) frequency tuning. A piezoelectric transducer (PZT) is used to make adjustments in the tuning arm position. The readout is in actual voltage that is applied to the PZT.

The Piezo Voltage control can change the laser frequency over sub-GHz range, which is easily seen on a wavemeter of sufficient accuracy. To change the Piezo voltage setting turn the knob control that is positioned below the PZT Voltage reading on the display screen.

The Piezo Voltage can be changed only when its Knob Enable button is pressed and the button LED is lit. To disable the Piezo Voltage set knob press the Knob Enable button again.

4.2.3 Function Generator

The Function Generator is used for analog control of the wavelength through the voltage applied to the PZT on the tuning arm. The wavelength modulation can be achieved either with the function generator, or with the external generator applied at the rear panel BNC connector (Section 4.4.6).

Press the Function Generator button to display the internal generator Amplitude and Frequency.

Use the knobs to adjust the generator to the desired parameters. The internal generator is used to sweep the piezo voltage with the set amplitude and frequency. The signal shape can be triangle waveform or sinewave.

When the generator is set, push the Sweep button to start modulating the piezo voltage. Press the Sweep button again to stop the modulation. When sweeping, the laser frequency is modulated with the set signal shape, frequency and amplitude.

4.2.4 Feed Forward

TLB-6800-LN has a feed forward feature, which can be enabled with the FEED FFW button. When the button LED is lit, the function is enabled. Feed Forward modulates the laser current source with a signal which has the same shape and frequency as the piezo voltage modulation. The Feed Forward laser current amplitude is proportional with the piezo voltage modulation amplitude. The following equation governs the feed forward current amplitude: $I_{ff} = K * (V_{act} - V_{set})$, where I_{ff} is the feed forward current, V_{act} is the actual piezo voltage, V_{set} is the voltage setpoint reference captured by the controller when feed forward feature is enabled, and K is feed forward coefficient. The units for K are mA/V, and default value is -0.8. K can be any value between -5.0 and 5.0. The total contribution of feed forward current may not exceed ± 20 mA.

Feed Forward works with either the internal generator, when the Sweep function is enabled (Section 4.2.3), or with the external generator which can be attached at the Frequency Modulation input (Section 4.4.6).

The user has to be careful when Feed Forward is enabled not to exceed the laser maximum current limit. If the laser current limit is exceeded inadvertently, TLB-7100-LN limit protection is engaged, to protect the laser. See Section 4.2.5 for more about the limit protection.

4.2.5 Laser Current Limit Protection

One of the parameters stored in the laser head TLB-71XX-XX internal memory is the Laser Current Maximum Limit. This limit can only be exceeded if the laser current is over modulated. The laser current maximum modulation amplitude is ± 20 mA, whether the modulation comes from the Feed Forward circuit (see Section 4.2.4), or from the Current Modulation BNC input at the rear panel (see Section 4.4.7).

Normal operation occurs only when the sum of the laser current set point and the modulation amplitude do not exceed the maximum limit. To protect the laser from being inadvertently driven over the limit, TLB-7100-LN employs two over-the-limit conditions: SOFT LIMIT and HARD LIMIT.

If the current limit is exceeded by more than 2 mA, the system enters the SOFT LIMIT condition, in which the FEED FWD LED will start blinking, to

make the user aware that the laser is overdriven. When the user decreases the modulation amplitude, or the laser current level below the limit, the LED will stop blinking and the system returns to normal operation.

If the current limit is exceeded by more than 7 mA, the system enters the HARD LIMIT condition, in which the unit will shut the laser immediately and display an error message. To return to normal operation the user needs to reduce the modulation amplitude or the laser current level below the limit and then turn the laser power ON from the LASER POWER button.

4.3 Menu Section

In addition to showing status parameters on the display the Menu section of the front panel enables users to view/change more parameters.

4.3.1 Control Knobs

The TLB-6800-LN has two control knobs. Each knob changes values of the parameter shown in the area of the display directly above the knob. The control knob on the right side of the front panel is used to set the value of Current, Function generator frequency, and all other parameters in the Menu. There are Knob Enable buttons next to each knob. The knob is active when the LED in the Knob Enable button is on. To disable the knob, press the Knob Enable button and the LED will turn off. Only the right knob can be activated when navigating the Menu. The right knob also allows the user to scroll through the Menu.

The knob has an acceleration algorithm that causes the rate of change of value to increase as the knob is turned faster. Turning slowly allows for fine adjustment at the smallest displayed digit.

4.3.2 Enter

The Enter key is used to (a) invoke the Setup screen, (b) accept parameter change, or (c) enter a lower menu level, depending on the screen displayed.

4.3.3 Display Elements

The Model TLB-6800-LN Controller uses a character display to depict information about the current state of the system. The display screens shown by the instrument can be classified as follows: title screen, laser head information screen, main Setup screen, parameter setup screen and error message screen.

4.3.4 Menu Selection

The Menu is accessed by pressing the Menu button and the LED is ON. The right knob or Scroll button can be used to scroll through the menu items. Use the Enter button to enter a sub-menu. The right knob is used to change values. The Back button returns to the previous screen.

4.3.5 Title Screen

The Title screen is displayed for a few seconds every time the instrument is powered ON. A sample Title screen is shown in Figure 20.



Figure 20 A Sample Title Screen

4.3.6 Instrument Firmware Version Screen

Immediately after the Title screen, the next screen shows the instrument firmware version and date.

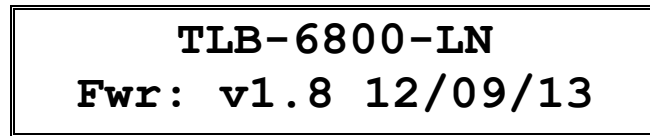

Figure 21 A Sample Title Screen

4.3.7 Laser Head Information Screen

The Laser Head Information screen is displayed for a few seconds after the Instrument Firmware Version screen every time the instrument is powered ON. This screen is used to display the model and serial number of the laser head connected to the controller. A sample screen is shown in Figure 22.

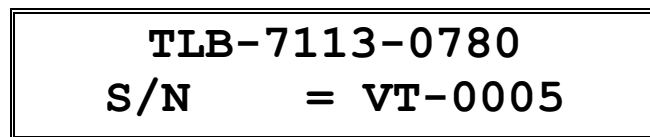

Figure 22 *A Sample Laser Head Information Screen*

4.3.8 Main Screen

The Main screen is displayed after the controller has been powered ON for a few seconds. The Current and Voltage Knob Enable button LEDs will be on to indicate that the front panel knobs are enabled to allow the user to change the laser current and piezo voltage setpoints.

When the unit is turned ON for the first time the main screen will show zero piezo voltage and zero laser current. Figure 23 shows a sample of this screen.

Figure 23 *A Sample Main Screen*

4.3.9 Parameter Setup Screens

The Parameters Setup Screens are displayed after the user pushes the Menu button. Figure 24 shows the first screen.

Scrolling through different parameters can be done with the Scroll button. The Enter button is used to go into a submenu. The Back button is used to return to a parent menu.

Use the right knob (the only one enabled) to change the numbers for each parameter.

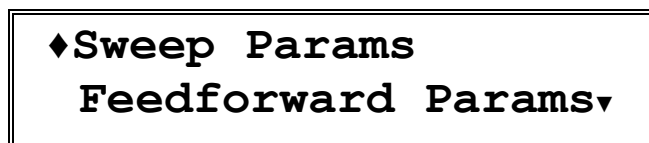
Figure 24 *A Sample Params Setup Screen*

The following figure shows the menu structure and navigation.

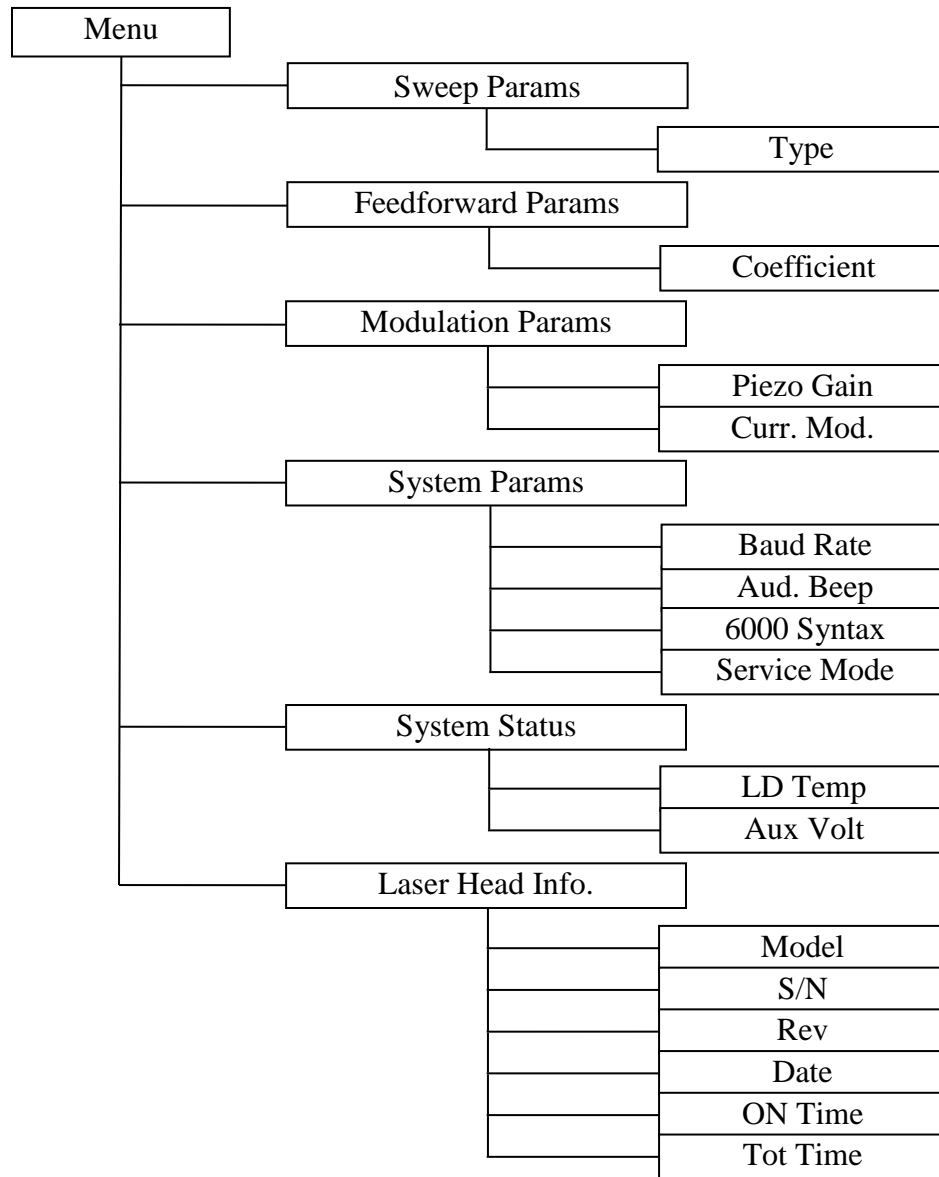

Figure 25 Model 6800 Menu Structure

4.4 Rear Panel

The Model TLB-6800-LN rear panel has various dedicated input and output connectors, as well as important labeling. (See below)

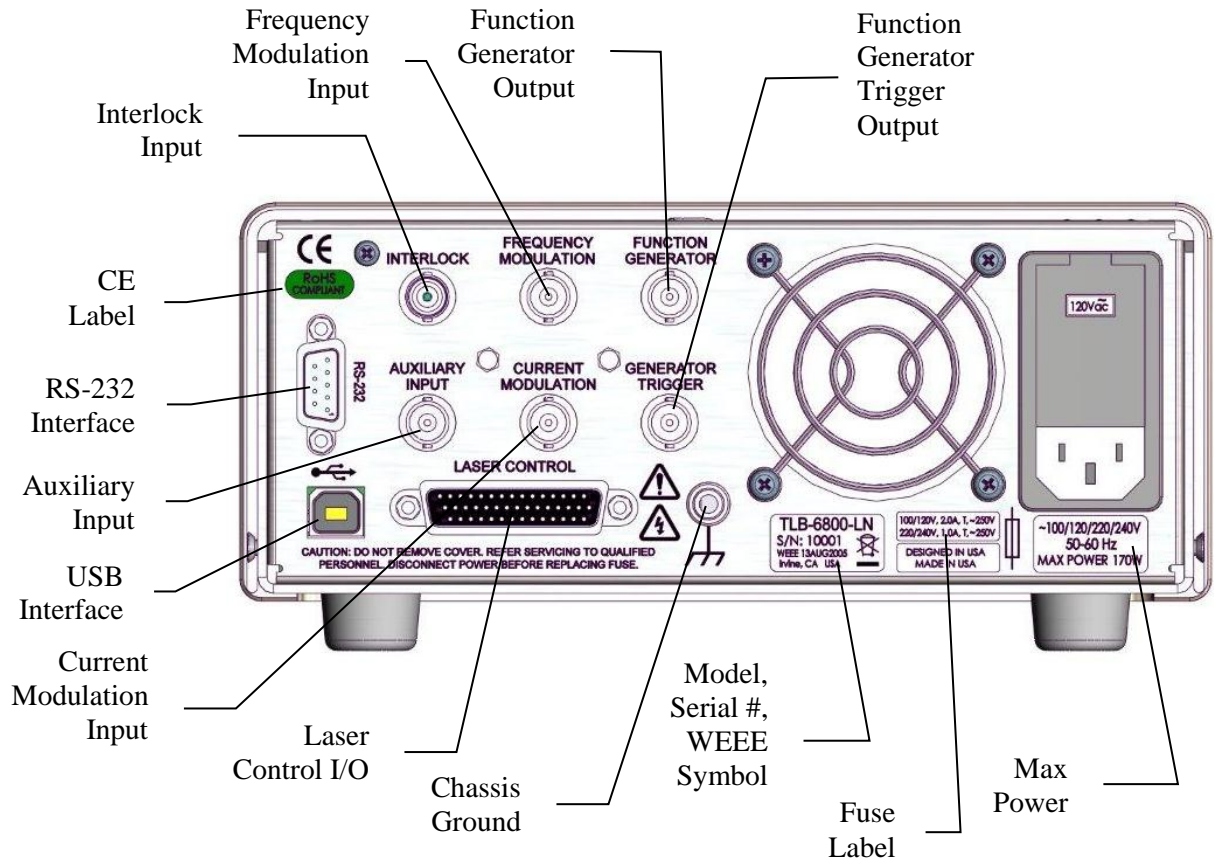

Figure 26 Rear Panel

4.4.1 USB Interface

The TLB-6800-LN is designed to communicate with standard USB Host interfaces. The connector on the rear panel is a standard USB-B (Full-Size, Device).

4.4.2 RS-232 Serial Interface

The TLB-6800-LN is designed to communicate with standard RS-232 serial interface. The connector on the rear panel is a standard female 9-pin Dsub.

Note that the built-in serial port on a PC is a DTE device. A straight-through cable is used to connect a DTE device (PC) to a DCE device (e.g., TLB-6800-LN). The TXD-RXD and RTS-CTS pins are not cross-connected in this case, hence the term straight through cable.

Simple Straight Through Cable

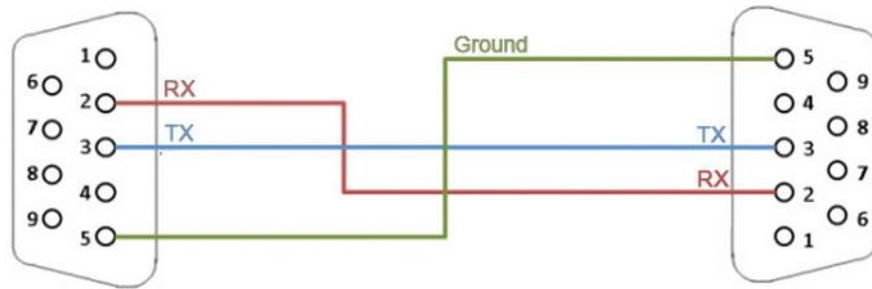

4.4.3 Chassis GND

This 4 mm banana jack is connected to chassis ground. It is intended to be used as an additional earth ground connection for the Model TLB-6800-LN's enclosure.

4.4.4 AC Power Cord

The Model TLB-6800-LN can be operated on either 50 or 60 Hz mains power. The instrument can be configured for operation at the following nominal AC line voltages -- 100, 120, 220, 230, or 240 VAC. See section 3.6 for information on properly configuring the Model 6800 for the available mains power.

The line cord supplied with each unit should be plugged only into a properly grounded outlet to prevent electrical shock in the event of an internal short circuit to the metal cabinet. The detachable line cord should be connected to the IEC320 connector on the power entry module.

4.4.5 Fuses

The correct fuses must be installed into the fuse holder that is part of the AC power entry module. Please check the fuse label on the rear panel, before installing new fuses (see Figure 26).

**WARNING**

To avoid electric shock, the appropriate fuses for the AC input power voltage must be installed in the instrument. Only qualified service personnel should replace fuses. Failure to observe these precautions can result in fire, severe injury or death.

4.4.6 Frequency Modulation Input

The Frequency Modulation input is for external analog control of the wavelength through the voltage applied to the PZT on the tuning arm. It is useful for making fine-frequency adjustments and for FM spectroscopy. Sweeping the Frequency Modulation input from -2.25 V to +2.25 V corresponds to changing the laser frequency by an amount on the order of -30 GHz to +30 GHz for certain models. The actual modulation you will observe depends on the wavelength range of the laser head (see the Acceptance Test Data Sheet of your particular laser) and on the rate and amplitude of the incoming signal (for example, full 30-GHz modulation is only available at rates up to 200 Hz). The Frequency Modulation input will accept triangle waveforms from DC to 2 kHz with an amplitude of +/-0.3 V, and DC to 700 Hz with an amplitude of +/-3V. The instrument will protect itself from going over these signal values, to prevent overheating of the piezo actuator or internal circuitry. The protection gradually decreases the input amplitude if the user inadvertently goes over the specified amplitude values. In the rare occasions when the unit overheats, especially when the vents are obstructed or the temperature in the room is above specifications, the unit will temporarily reduce the input signal amplitude to 1/10 of the maximum value. The instrument automatically resumes normal operation when the user responds appropriately to cool the system or reduce the input signal or frequency.

Decreasing voltage at the Frequency Modulation input corresponds to a decrease in piezo voltage and an increase in laser frequency (or a decrease in laser wavelength).

4.4.7 Current Modulation Input

The Current Modulation input allows the user to modulate the diode current at rates up to 1 MHz. This input accepts -10 to +10 V into a DC-coupled 1 k Ω resistive load and provides 2 mA/V modulation, for a maximum of +/-20mA current modulation peak. This input is summed with the front-panel setting. Note that the front panel current readout does not reflect the modulation input.

The user has to be careful when the current modulation is enabled not to exceed the laser maximum current limit. If the laser current limit is exceeded inadvertently, TLB-7100-LN limit protection is engaged, to protect the laser. See Section 4.2.5 for more about the limit protection.

4.4.8 High-Speed Current Modulation

For high-speed current modulation up to 100 MHz, an SMA connector on the laser head is provided. This input is AC coupled; the low- and high-frequency roll off points are below 10 kHz and about 100 MHz, depending on the model. The current modulation provided by this input is approximately 20 mA/V. To prevent damage to the diode laser, the voltage swing on this input must be less than 1 V_{p-p}.

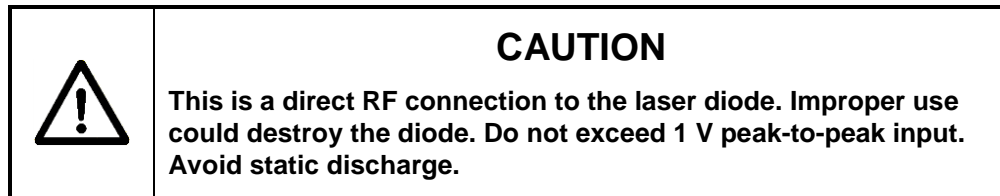

Since this is a direct connection to the diode laser, there is no current limit circuit that prevents too much current from passing through the diode. Thus, there is a danger of destroying the diode if the maximum current is exceeded. Be sure that the current modulation applied to the laser diode will not result in driving the diode above its maximum current. (See included Acceptance Test Data Sheet.)

The high-speed input has a protective shorting cap which should remain in place during normal operation. When removing the shorting cap to connect a high-frequency driver, be sure to wear a ground strap to prevent static discharge. Please contact New Focus if you have any questions on how to use the high-speed modulation input. Make sure to turn off power to the diode before connecting any device to the high-speed input.

4.4.9 Auxiliary Input

The Auxiliary Input is a 16-bit analog-to-digital converter input to the digital signal processor (DSP). Analog signals that you connect here can be read out by your computer when you use remote control. This is a general-purpose input that allows you to collect data from a photodetector during a wavelength scan or, for example, to create your own Constant-Power mode with an external detector. The Auxiliary Input will accept signals from 0 to +5 volts and presents a 40 kΩ load.

5 Computer Interfacing

5.1 Introduction

The Model 6800 Tunable Laser Controller has USB and RS-232 interfaces to receive commands from, and send responses to, a host PC. The commands supported by the controller can be divided into the following two categories: commands that cause it to take a desired action, and commands (queries) that cause it to return a stored value.

Query commands must end with a question mark (?). It is recommended that when a query command is sent, the response to that command from the instrument be read before issuing any other command.

Set commands, on the other hand, are used to configure/setup the controller for a desired mode of operation. These commands take at least one parameter. If the controller executed the command successfully, it responds with an “OK” string. Otherwise, it returns an error message. The subsequent sections in this chapter detail the communication protocols supported by the instrument.

5.2 Computer Interface Terminology

Listed below are the key abbreviations and concepts used in the command reference section of this manual.

5.2.1 <...> Delimiting Punctuation

For the purposes of this manual, any string enclosed by <...> is considered to be a command, a string or numerical argument. The punctuation <...> is used to symbolize the typographic limits of the command, string or argument in question.

5.2.2 <CR> Carriage Return

The ASCII encoded byte 13 in decimal. (0D hex)

5.2.3 <LF> Line Feed

The ASCII encoded byte 10 in decimal. (0A hex)

5.2.4 (;) Semicolons

Semicolons are used to separate commands within a single transmission (concatenation).

5.2.5 Command Termination

All the commands sent to the driver must be terminated by a <CR><LF> sequence.

5.2.6 Response Termination

All the responses from the driver are terminated by a <CR><LF> sequence.

5.3 Controller Operation Mode

The Tunable Laser Controller supports two modes of operation: LOCAL and REMOTE. The controller will be in LOCAL mode, by default, following a power reset. In this mode, all the main setpoints and system parameters can be adjusted by turning the control knob on front panel of the controller. Output can be turned ON and OFF by pressing the Laser Power button. Please refer the “System Operation” chapter for a detailed description on how to accomplish these tasks. When the controller is in REMOTE mode, knob control is disabled; setpoints and other settings can be adjusted only by issuing appropriate commands from a host PC.

The controller can be put into REMOTE mode by issuing the command “SYSTEM:MCONTROL REM”. It can be put back in LOCAL mode by issuing “SYSTEM:MCONTROL LOC” command.

5.4 USB Communication

The instrument is designed to communicate with a host PC via a standard USB interface. Before connecting the instrument to the USB interface the user should install the application included in the software CD that accompanies the Tunable Laser Controller. The application automatically installs the right USB drivers. Communication can be done through this interface by using the application or by developing software in the user’s preferred programming language. The software CD contains communication drivers and example programs in the following programming languages: LabVIEW and C#.NET.

5.5 RS-232 Communication

The instrument is designed to communicate with a host PC via RS-232 communication interface. The pin out of the 9-pin D-sub connector located on the rear panel of the controller is designed to interface directly with an IBM-compatible PC using a straight-through cable.

To communicate with the instrument, the host PC’s RS-232 settings must be configured as follows: 8 data bits, no parity checking, 1 stop bit, and no

hardware handshake. The controller can support baud rates between 1200 and 57600 bps; the default baud rate is 19200 bps.

Setting the Baud Rate for RS-232

1. Press the Menu button and scroll down to System Params menu. Press Enter button to see this menu. The first menu item is Baud Rate.
2. Turn the right-knob to select desired baud rate. Turn the knob clockwise to increase the value, counter-clockwise to decrease the value. Available baud rates are 1200, 2400, 4800, 9600, 19200, 38400, and 57600.
3. Press the Back button to exit the System Params menu.

5.6 Commands Summary

5.6.1 Conventions

There are two types of device commands: commands that cause the instrument to take a desired action, and queries that return a stored value or state of the instrument. Queries must end with a question mark (?), while commands may require parameter(s) to follow:

SOURce:CURRent:DIODE 60.00

For example, the value “60.00” in the command **SOURce:CURRent:DIODE 60.00** sets the diode current setpoint to 60.00 mA. The command/query **MUST** contain all of the letters shown in upper-case; lower-case letters in the commands are optional, and may be used for clarity.

The commands may be sent to the instrument in either upper or lower case or in any combination. For example, the following commands are equal:

SOURce:CURRent:DIODE 60.00

SOUR:CURR:DIOD 60.00

source:current:diode 60.00

Source:Current:Diode 60.00

COMMAND TERMINATION:

All commands sent to the controller must be terminated by <Carriage Return><Line Feed>.characters. All responses sent out by the controller are terminated by the same characters.

5.6.2 Types of Commands

There are five general types of commands: Standard Commands, Output Commands, Sense Commands, Source Command, and System Commands.

Standard Commands allow you to get information about the controller, and to set controller-specific parameters such as beeper, front panel etc. System Commands allow users to query laser, and any system-level information.

Output Commands are used to turn ON/OFF various outputs that affect laser performance. They can be used to query the state of the output also.

Source Commands are used to set/query laser operating parameters. Queries return the value of various controller set points.

Sense Commands return the value of various laser operating conditions. Sense Commands read actual voltages, currents, and temperatures; the value returned is the same as that seen on the controller front panel at the time the command is executed.

The next section has an index of all the possible computer control commands. Then, the pages that follow the index of commands give detailed information about each command, including a description of the command and examples of how the command is used.

5.6.3 Index of Commands

Standard Commands

Syntax	Description
*IDN?	Identification string query
*RCL	Recall controller settings
*RST	Reset the controller
*SAV	Save controller settings
BEEP	Set controller beeper status
BEEP?	Query controller beeper status
LOCKOUT	Set controller front panel state
LOCKOUT?	Query controller front panel state
ONDELAY	Set laser output ON delay
ONDELAY?	Query laser output ON delay

Output Commands

Syntax	Description
OUTPut:CURRent:FFWD	Set current feedforward state
OUTPut:CURRent:FFWD?	Query current feedforward state
OUTPut:CURRent:MODulate	Set current modulation state
OUTPut:CURRent:MODulate?	Query current modulation state
OUTPut:STATe	Set laser output state
OUTPut:STATe?	Query laser output state
OUTPut:SWEEP	Set function generator state
OUTPut:SWEEP?	Query function generator state

Sense Commands

Syntax	Description
SENSe:CURRent:DIODE?	Sense diode current
SENSe:TEMPerature:TEC?	Sense TEC (diode) temperature
SENSe:VOLTag:e:PIEzo?	Sense piezoelectric voltage
SENSe:VOLTag:e:AUXiliary?	Sense voltage from auxiliary input

Source Commands

Syntax	Description
SOURce:CURRent:DIODE	Set diode current setpoint
SOURce:CURRent:DIODE?	Query diode current setpoint
SOURce:CURRent:FFCOEFF	Set feedforward coefficient
SOURce:CURRent:FFCOEFF?	Query feedforward coefficient
SOURce:SWEEP:AMPLitude	Set function generator amplitude
SOURce:SWEEP:AMPLitude?	Query function generator amplitude
SOURce:SWEEP:FREQuency	Set function generator frequency
SOURce:SWEEP:FREQuency?	Query function generator frequency
SOURce:SWEEP:TYPE	Set function generator type
SOURce:SWEEP:TYPE?	Query function generator type
SOURce:TEMPerature:TEC	Set diode temperature setpoint
SOURce:TEMPerature:TEC?	Query diode temperature setpoint

SOURce:VOLTage:PIEZO	Set piezoelectric voltage setpoint
SOURce:VOLTage:PIEZO?	Query piezoelectric voltage setpoint
SOURce:VOLTage:PZGAIN	Set piezoelectric voltage gain
SOURce:VOLTage:PZGAIN?	Query piezoelectric voltage gain

System Commands

Syntax	Description
SYSTem:BAUDRATE	Set RS-232 baud rate
SYSTem:BAUDRATE?	Query RS-232 baud rate
SYSTem:ENTIME?	Query laser usage time
SYSTem:MCONtrol	Set controller operation mode
SYSTem:MCONtrol?	Query controller operation mode
SYSTem:SYNTAX	Set RS-232 syntax compatibility
SYSTem:SYNTAX?	Query RS-232 syntax compatibility
SYSTem:LASer:MODEL?	Query laser model number
SYSTem:LASer:SN?	Query laser serial number
SYSTem:LASer:REV?	Query laser revision number
SYSTem:LASer:CALDATE?	Query laser calibration date
SYSTem:LASer:WAVElength?	Query laser wavelength
SYSTem:LASer:CONDition?	Query laser condition register

IDN?*Description** Identification string query.**Syntax** *IDN?**Remarks** This query will cause the instrument to return an identification string.

	Model Name	Firmware Version #	Firmware Date	Controller Serial #
	⏟	⏟	⏟	⏟

New_Focus XXXX vYYY mm/dd/yy, SNZZZZ

RCL*Description** Recall command.**Syntax** *RCL *Bin*

Argument	Value	Description
<i>Bin</i>	0	Restores factory default settings
	1 to 5	Restores settings saved in specified bin

Remarks This command restores the instrument to the setup states saved in instrument's non-volatile flash memory. The parameters that can be restored are:

1. Beeper enable state
2. Dial (rotary knob) lockout state
3. Laser output on-delay duration
4. RS-232 baud rate
5. 6000 controller RS-232 syntax compatibility
6. Hardware configuration register setting
7. Current modulation state
8. Diode current setpoint
9. Diode feedforward current coefficient
10. Diode temperature setpoint
11. Piezo voltage setpoint
12. Piezo gain
13. Sweep (internal function generator) amplitude
14. Sweep (internal function generator) frequency
15. Sweep (internal function generator) type

See Also *RST, *SAV

RST*Description** Reset command.**Syntax** *RST**Remarks** This command performs a soft reset of the instrument.**See Also** *RCL

***SAV**

Description Save command.

Syntax ***SAV** *Bin*

Argument	Value	Description
<i>Bin</i>	2 to 5	Saves current settings to specified bin

Remarks This command stores the current state of the instrument in non-volatile flash memory. This state is then recalled using the ***RCL** command. See description of ***RCL** command for a list of values saved/recalled by the instrument.

See Also ***RCL**

BEEP

Description Beep command

Syntax **BEEP** *Value*

Remarks This command controls the instrument's beeper. The beeper is used to signal error or warning conditions.

If no value is specified:

- The controller returns "NO PARAMETER SPECIFIED".
- No other action is taken.

If the value specified is not equal to 0, 1 or 2:

- The controller returns "VALUE OUT OF RANGE".
- No other action is taken.

If the value is 0, 1 or 2:

- The beeper state is changed per table below.
- The controller returns "OK".

Argument	Value	Description
<i>Value</i>	0	Beeper off
	1	Beeper on
	2	Test beeper (100ms beep)

See Also **BEEP?**

BEEP?**Description** Beep query**Syntax** **BEEP?****Remarks** This query returns the enable status of the beeper.

Response	Description
<i>beep set</i>	0 Beeper off
	1 Beeper on

See Also **BEEP**

LOCKOUT**Description** Lockout the instrument front panel.**Syntax** **LOCKOUT** *Value***Remarks** This command can be used to lockout all the buttons and dial knob or just the dial knob on the front panel.

If no value is specified:

- The controller returns “NO PARAMETER SPECIFIED”.
- No other action is taken.

If the value specified is not equal to 0, 1 or 2:

- The controller returns “VALUE OUT OF RANGE”.
- No other action is taken.

If the value is 0, 1 or 2:

- The front panel state is changed per table below.
- The controller returns “OK”.

Argument	Value	Description
<i>Value</i>	0	Front panel buttons and dial knobs enabled
	1	Front panel buttons and dial knobs disabled
	2	Front panel dial knob disabled

See Also **None**

LOCKOUT?**Description** Instrument front panel lockout state query.**Syntax** **LOCKOUT?****Remarks** **This query returns the instrument’s** front panel lockout state.

Response	Description <i>Value</i> Front panel lockout state
See Also	LOCKOUT

ONDELAY

Description	Laser turn on delay command.
Syntax	ONDELAY <i>time</i>
Remarks	This command controls the laser turn on delay. This is the amount of time between the moment the laser on command is received and the moment the output is actually energized. This setting is also used when a laser is commanded to turn on by pushing the LASER POWER button on front panel of instrument when it is in local control mode.

If no value is specified:

- The controller returns “NO PARAMETER SPECIFIED”.
- No other action is taken.

If the value specified is less than 6000 or greater than 60000:

- The controller returns “VALUE OUT OF RANGE”.
- No other action is taken.

If the value is in range:

- The laser turn on delay is changed to desired value.
- The controller returns “OK”.

Argument	Value Description <i>Time</i> <i>Integer</i> Time, in milliseconds. Valid values are between 6000 and 60000
-----------------	--

See Also **ONDELAY?**

ONDELAY?

Description	Laser turn on delay query
Syntax	ONDELAY?
Remarks	This command returns the laser turn on delay time.
Response	Description <i>Value</i> Time, in milliseconds
See Also	ONDELAY

OUTPut:CURRent:FFWD

Description Laser current feedforward enable command.

Syntax **OUTPut:CURRent:FFWD** *State*

Remarks This command turns the laser current feedforward ON or OFF. When the feedforward is turned ON, the controller captures the piezo voltage setpoint at that instance and uses it to determine the actual feedforward current. The actual feedforward current is determined using the following equation:

$I_{ff} = K * (V_{actual} - V_{setpoint})$, where I_{ff} is the actual feedforward current; K is the feedforward coefficient, V_{actual} is the actual piezo voltage, $V_{setpoint}$ is the piezo voltage setpoint captured when this command is issued.

If no value is specified:

- The controller returns “NO PARAMETER SPECIFIED”.
- No other action is taken.

If the value specified is not equal to 0 or 1:

- The controller returns “VALUE OUT OF RANGE”.
- No other action is taken.

If the value is 0 or 1:

- The laser current feedforward feature is turned OFF or ON.
- The controller returns “OK”.

Argument	Value	Description
	<i>State</i>	<i>Integer</i>
		0 turns the laser feedforward OFF
		1 turns the laser feedforward ON

See Also **OUTPut:CURRent:FFWD?**; **SOURce:CURRent:FFCOEFF**

OUTPut:CURRent:FFWD?

Description Laser current feedforward enable state query

Syntax **OUTPut:CURRent:FFWD?**

Remarks This command returns the laser current feedforward enable state.

Response	Description
<i>Value</i>	0 laser feedforward OFF
	1 laser feedforward ON

See Also **OUTPut:CURRent:FFWD**; **SOURce:CURRent:FFCOEFF**

OUTPut:CURRent:MODulate

Description Laser current modulation enable command.

Syntax **OUTPut:CURRent:MODulate State**

Remarks This command turns the laser current modulation ON or OFF.

If no value is specified:

- The controller returns “NO PARAMETER SPECIFIED”.
- No other action is taken.

If the value specified is not equal to 0 or 1:

- The controller returns “VALUE OUT OF RANGE”.
- No other action is taken.

If the value is 0 or 1:

- The laser current modulation is turned OFF or ON.
- The controller returns “OK”.

Argument	Value	Description
	<i>State</i>	Integer
		0 turns the laser current modulation OFF
		1 turns the laser current modulation ON

See Also **OUTPut:CURRent:MODulate?;**

OUTPut:CURRent:MODulate?

Description Laser current modulation enable state query

Syntax **OUTPut:CURRent: MODulate?**

Remarks **This command returns the laser current modulation enable state.**

Response	Description
<i>Value</i>	0 laser current modulation OFF
	1 laser current modulation ON

See Also **OUTPut:CURRent:MODulate**

OUTPut:STATe

Description Laser output enable command.

Syntax **OUTPut:STATe State**

Remarks This command turns the laser ON or OFF. When turning the laser ON, the light above the front panel's LASER POWER switch will flash for six seconds (default) before the power is turned ON. The flash time can be changed using the ONDELAY command.

If no value is specified:

- The controller returns "NO PARAMETER SPECIFIED".
- No other action is taken.

If the value specified is not equal to 0 or 1:

- The controller returns "VALUE OUT OF RANGE".
- No other action is taken.

If the value is 0 or 1:

- The laser output is turned OFF or ON.
- The controller returns "OK".

Argument	Value	Description
	<i>State</i>	<i>Integer</i>
		0 turns the laser OFF
		1 turns the laser ON

See Also **ONDELAY?; OUTPut:STATe?**

OUTPut:STATe?

Description Laser output enable state query

Syntax **OUTPut:STATe?**

Remarks This command returns the laser output enable state.

Response	Description
<i>Value</i>	0 laser output OFF
	1 laser output ON

See Also **ONDELAY; OUTPut:STATe**

OUTPut:SWEEP

Description Sweep (internal function generator) enable command.

Syntax **OUTPut:SWEEP State**

Remarks This command turns the internal function generator ON or OFF. Turning this feature ON enables frequency modulation.

If no value is specified:

- The controller returns “NO PARAMETER SPECIFIED”.
- No other action is taken.

If the value specified is not equal to 0 or 1:

- The controller returns “VALUE OUT OF RANGE”.
- No other action is taken.

If the value is 0 or 1:

- The internal function generator is turned OFF or ON.
- The controller returns “OK”.

Argument	Value	Description
	<i>State</i>	<i>Integer</i>
		0 turns the internal function generator OFF
		1 turns the internal function generator ON

See Also **OUTPut:SWEEP?**

OUTPut:SWEEP?

Description Sweep (internal function generator) enable state query

Syntax **OUTPut:SWEEP?**

Remarks This command returns the internal function generator enable state.

Response	Description
<i>Value</i>	<i>0</i> internal function generator <i>OFF</i>
	<i>1</i> internal function generator <i>ON</i>

See Also **OUTPut:SWEEP**

SENSe:CURRent:DIODE?

Description Actual laser diode current query

Syntax **SENSe:CURRent:DIODE?**

Remarks This command returns the magnitude of actual laser diode current. The value returned is same as that seen on the front panel of the controller at the time this command is executed.

Response	Description
<i>Value</i>	<i>Actual laser diode current in milli-Amperes (mA).</i>

See Also **SOURce:CURRent:DIODE; SOURce:CURRent:DIODE?**

SENSe:TEMPerature:TEC?

Description	Actual laser diode temperature query
Syntax	SENSe:TEMPerature:TEC?
Remarks	This command returns the magnitude of actual laser diode temperature. Note that the diode temperature is actively controlled. If the room temperature ever gets so high that the coolers have insufficient capacity to reduce the temperature, the control loop can become unstable and destroy the cooling elements. To prevent damage, the laser is automatically shut down if the laser-diode temperature exceeds safe limits.
Response	Description <i>Value</i> Actual laser diode temperature in degC (oC).
See Also	SOURce:TEMPerature:TEC; SOURce:TEMPerature:TEC?

SENSe:VOLTage:PIEZO?

Description	Actual piezoelectric voltage query
Syntax	SENSe:VOLTage:PIEZO?
Remarks	This command returns the magnitude of actual piezo voltage. Note that as the piezo voltage increases, the lasing frequency increases and the wavelength decreases.
Response	Description <i>Value</i> Actual piezo voltage in Volts
See Also	SOURce:VOLTage:PIEZO; SOURce:VOLTage:PIEZO?

SENSe:VOLTage:AUXiliary?

Description	Actual auxiliary input voltage query
Syntax	SENSe:VOLTage:AUXiliary?
Remarks	This command returns the magnitude of actual auxiliary input voltage. The resolution of this voltage is about 79 μ V.
Response	Description <i>Value</i> Actual auxiliary detector input voltage in Volts (V).
See Also	None

SOURce:CURRent:DIODE

Description	Diode laser current set.
Syntax	SOURce:CURRent:DIODE <i>Value</i>

Remarks This command sets the diode laser current setpoint.

If no value is specified:

- The controller returns “NO PARAMETER SPECIFIED”.
- No other action is taken.

If the value specified is greater than the diode current rating:

- The controller returns “VALUE OUT OF RANGE”.
- No other action is taken.

If the value is in range:

- The diode laser current is changed to specified value.
- The controller returns “OK”.

Argument	Value	Description
<i>Value</i>	MAX	If the string “MAX” is specified as value, the diode current setpoint is set to the diode’s current rating
	Float	Desired diode laser current in milli-Amperes (mA)

See Also **SOURce:CURRent:DIODE?**

SOURce:CURRent:DIODE?

Description Diode laser current setpoint query.

Syntax **SOURce:CURRent:DIODE?**

Remarks This query returns the diode laser current setpoint.

Response **Description**
Value Diode laser current setpoint in milli-Amperes (mA)

See Also **SOURce:CURRent:DIODE**

SOURce:CURRent:FFCOEFF

Description Diode laser feedforward current coefficient set.

Syntax **SOURce:CURRent:FFCOEFF** *Value*

Remarks This command sets the diode laser feedforward current coefficient.

If no value is specified:

- The controller returns “NO PARAMETER SPECIFIED”.
- No other action is taken.

If the value specified is less than -5.0 mA/V or greater than 5.0 mA/V:

- The controller returns “VALUE OUT OF RANGE”.
- No other action is taken.

If the value is in range:

- The laser feedforward current coefficient is changed to specified value.
- The controller returns “OK”.

Argument	Value	Description
<i>Value</i>	MIN	If the string “MIN” is specified as value, the laser feedforward current coefficient is set to -5.0 mA/V.
	MAX	If the string “MAX” is specified as value, the laser feedforward current coefficient is set to 5.0 mA/V.
	Float	Desired laser feedforward current coefficient in milli-Amperes/Volt (mA/V)

See Also **SOURce:CURRent:FFCOEFF?**

SOURce:CURRent:FFCOEFF?

Description Diode laser feedforward current coefficient query.

Syntax **SOURce:CURRent:FFCOEFF?**

Remarks This query returns the diode laser feedforward current coefficient.

Response **Description**
Value Diode laser feedforward current coefficient in milli-Amperes/Volt (mA/V)

See Also **SOURce:CURRent:FFCOEFF**

SOURce:SWEEP:AMPlitude

Description Internal function generator amplitude set.

Syntax **SOURce:SWEEP:AMPlitude** *Value*

Remarks This command sets the internal function generator amplitude. 94 different amplitudes, between 0.0V and 60.0V, can be set using this command. The lookup table below shows the actual internal function generator amplitude for various values provided with this command.

If no value is specified:

- The controller returns “NO PARAMETER SPECIFIED”.
- No other action is taken.

If the value specified is greater than 93:

- The controller returns “VALUE OUT OF RANGE”.

- No other action is taken.

If the value is in range:

- The internal function generator amplitude is changed based on the lookup table below.
- The controller returns “OK”.

Value	Amplitude (V)
0	0.00
1	0.23
2	0.47
3	0.70
4	0.94
5	1.17
6	1.41
7	1.64
8	1.88
9	2.11
10	2.34
11	2.58
12	2.81
13	3.05
14	3.28
15	3.52
16	3.75
17	3.98
18	4.22
19	4.45
20	4.69
21	4.92
22	5.16
23	5.39
24	5.63
25	5.86
26	6.09
27	6.33
28	6.56
29	6.80
30	7.03
31	7.27

Value	Amplitude (V)
32	7.50
33	7.73
34	7.97
35	8.20
36	8.44
37	8.67
38	8.91
39	9.14
40	9.38
41	9.61
42	9.84
43	10.00
44	11.00
45	12.00
46	13.00
47	14.00
48	15.00
49	16.00
50	17.00
51	18.00
52	19.00
53	20.00
54	21.00
55	22.00
56	23.00
57	24.00
58	25.00
59	26.00
60	27.00
61	28.00
62	29.00
63	30.00

Value	Amplitude (V)
64	31.00
65	32.00
66	33.00
67	34.00
68	35.00
69	36.00
70	37.00
71	38.00
72	39.00
73	40.00
74	41.00
75	42.00
76	43.00
77	44.00
78	45.00
79	46.00
80	47.00
81	48.00
82	49.00
83	50.00
84	51.00
85	52.00
86	53.00
87	54.00
88	55.00
89	56.00
90	57.00
91	58.00
92	59.00
93	60.00

See Also **SOURce:SWEEP:AMPLitude?**

SOURce:SWEEP:AMPLitude?

Description Internal function generator amplitude query.

Syntax **SOURce:SWEEP:AMPLitude?**

Remarks This query returns the index to internal function generator amplitude lookup table.

Response **Description**
Value *Index to internal function generator lookup table*

See Also **SOURce:SWEEP:AMPLitude**

SOURce:SWEEP:FREQuency

Description Internal function generator frequency set.

Syntax **SOURce:SWEEP:FREQuency** *Value*

Remarks This command sets the internal function generator frequency.

If no value is specified:

- The controller returns “NO PARAMETER SPECIFIED”.
- No other action is taken.

If the value specified is greater than 100 Hz:

- The controller returns “VALUE OUT OF RANGE”.
- No other action is taken.

If the value is in range:

- The internal function generator frequency is changed to specified value.
- The controller returns “OK”.

Argument	Value	Description
<i>Value</i>	MAX	If the string “MAX” is specified as value, the internal function generator frequency is set to 100.0 Hz.
	Float	Desired internal function generator frequency in Hz.

See Also **SOURce:SWEEP:FREQuency?**

SOURce:SWEEP:FREQuency?

Description Internal function generator frequency query.

Syntax **SOURce:SWEEP:FREQuency?**

Remarks This query returns the internal function generator frequency.

Response	Description <i>Value</i> Internal function generator frequency in Hz.
See Also	SOURce:SWEEP:FREQuency

SOURce:SWEEP:TYPE

Description	Internal function generator type set.		
Syntax	SOURce:SWEEP:TYPE <i>State</i>		
Remarks	This command sets the internal function generator type to either Sinusoid or Triangle. If no value is specified: <ul style="list-style-type: none"> • The controller returns “NO PARAMETER SPECIFIED”. • No other action is taken. If the value specified is not equal to 0 or 1: <ul style="list-style-type: none"> • The controller returns “VALUE OUT OF RANGE”. • No other action is taken. If the value is 0 or 1: <ul style="list-style-type: none"> • The internal function generator type is changed to Sinusoid or Triangle. • The controller returns “OK”. 		
Argument	Value <i>State</i>	Description Integer	0 sets the type to Sinusoid 1 sets the type to Triangle
See Also	SOURce:SWEEP:TYPE?		

SOURce:SWEEP:TYPE?

Description	Internal function generator type query		
Syntax	SOURce:SWEEP:TYPE?		
Remarks	This command returns the internal function generator type.		
Response	Description <i>Value</i>	0	Internal function generator type is Sinusoid
		1	Internal function generator type is Triangle
See Also	SOURce:SWEEP:TYPE		

SOURce:TEMPerature:TEC

Description	TEC (Diode) temperature set.
--------------------	------------------------------

Syntax **SOURce:TEMPerature:TEC** *Value*

Remarks This command sets the Vantage laser diode TEC temperature.

If no value is specified:

- The controller returns “NO PARAMETER SPECIFIED”.
- No other action is taken.

If a non-Vantage laser head is connected to the controller:

- The controller returns “LASER PARAMS ACCESS DISABLED”.
- No other action is taken.

If the value specified is outside the laser temperature limits:

- The controller returns “VALUE OUT OF RANGE”.
- No other action is taken.

If the value is in range:

- The TEC (diode) temperature is changed to specified value.
- The controller returns “OK”.

Argument	Value	Description
<i>Value</i>	<i>MIN</i>	If the string “MIN” is specified as value, the diode temperature setpoint is set to the diode’s minimum rating
	<i>MAX</i>	If the string “MAX” is specified as value, the diode temperature setpoint is set to the diode’s maximum rating
	<i>Float</i>	<i>Desired diode temperature in degC (°C)</i>

See Also **SOURce:TEMPerature:TEC?**

SOURce:TEMPerature:TEC?

Description **TEC** (diode) temperature setpoint query.

Syntax **SOURce:TEMPerature:TEC?**

Remarks **This query returns the TEC temperature setpoint.**

Response **Description**
Value *TEC temperature setpoint in degC (°C)*

See Also **SOURce:TEMPerature:TEC**

SOURce:VOLTage:PIEZO

Description Piezoelectric transducer voltage set.

Syntax **SOURce:VOLTage:PIEZO** *Value*

- Remarks** This command sets the piezoelectric transducer voltage.
- If no value is specified:
- The controller returns “NO PARAMETER SPECIFIED”.
 - No other action is taken.
- If the value specified is greater than the laser piezo voltage limit:
- The controller returns “VALUE OUT OF RANGE”.
 - No other action is taken.
- If the value is in range:
- The piezo voltage is changed to specified value.
 - The controller returns “OK”.

Argument	Value	Description
<i>Value</i>	MAX	If the string “MAX” is specified as value, the piezo voltage setpoint is set to laser piezo voltage limit.
	Float	Desired piezo voltage in Volts (V)

See Also **SOURce:VOLTage:PIEZO?**

SOURce:VOLTage:PIEZO?

- Description** Piezoelectric transducer voltage setpoint query.
- Syntax** **SOURce:VOLTage:PIEZO?**
- Remarks** This query returns the piezo voltage setpoint.
- Response** **Description**
Value Piezo voltage setpoint in Volts (V)
- See Also** **SOURce:VOLTage:PIEZO**

SOURce:VOLTage:PZGAIN

- Description** External frequency modulation gain set.
- Syntax** **SOURce:VOLTage:PZGAIN** *Value*
- Remarks** This command sets the gain applied to external frequency modulation input.
- If no value is specified:
- The controller returns “NO PARAMETER SPECIFIED”.
 - No other action is taken.
- If the value specified is less than 0.0 or greater than 25.5:

- The controller returns “VALUE OUT OF RANGE”.
- No other action is taken.

If the value is in range:

- The frequency modulation gain is changed to specified value.
- The controller returns “OK”.

Argument	Value	Description
<i>Value</i>	Float	Desired frequency modulation gain

See Also **SOURce:VOLTage:PZGAIN?**

SOURce:VOLTage:PZGAIN?

Description External frequency modulation gain query.

Syntax **SOURce:VOLTage:PIEzo?**

Remarks This query returns the external frequency modulation gain.

Response **Description**
Value External frequency modulation gain

See Also **SOURce:VOLTage:PZGAIN**

SYSTEM:BAUDRATE

Description RS-232 baud rate set

Syntax **SYSTEM:BAUDRATE** *Value*

Remarks This command controls the instrument’s RS-232 baud rate.

If no value is specified:

- The controller returns “NO PARAMETER SPECIFIED”.
- No other action is taken.

If the value specified is less than 0 or greater than 6:

- The controller returns “VALUE OUT OF RANGE”.
- No other action is taken.

If the value is between 0 and 6:

- The RS-232 baud rate is changed per table below.
- The controller returns “OK”.

Argument	Value	Description
<i>Value</i>	0	Baud rate = 1200 bps
	1	Baud rate = 2400 bps

2	Baud rate = 4800 bps
3	Baud rate = 9600 bps
4	Baud rate = 19200 bps
5	Baud rate = 38400 bps
6	Baud rate = 57600 bps

See Also **SYSTem:BAUDRATE?**

SYSTem:BAUDRATE?

Description RS-232 baud rate query

Syntax **SYSTem:BAUDRATE?**

Remarks This query returns the RS-232 baud rate.

Response	Description
<i>Value</i>	
0	Baud rate = 1200 bps
1	Baud rate = 2400 bps
2	Baud rate = 4800 bps
3	Baud rate = 9600 bps
4	Baud rate = 19200 bps
5	Baud rate = 38400 bps
6	Baud rate = 57600 bps

See Also **SYSTem:BAUDRATE**

SYSTem:ENTIME?

Description Laser enable time query.

Syntax **SYSTem:ENTIME?**

Remarks This query returns the amount of time laser diode output has been enabled.

Response **Description**
Value Laser diode enable time in minutes (min)

See Also **OUTPut:STATe**

SYSTem:MCONtrol

Description Controller REMOTE/LOCAL operation mode set command.

Syntax **SYSTem:MCONtrol** *Mode*

Remarks This command is used to put the controller in remote/local operation mode. The controller will be in LOCAL mode, by default, following a power reset. In this mode, all the main setpoints and other system parameters can be adjusted by turning the control knobs on front panel of the controller. When it is in REMOTE mode, knob control is disabled; setpoints and other settings can be adjusted only by issuing appropriate commands from a host PC.

If no value is specified:

- The controller returns “NO PARAMETER SPECIFIED”.
- No other action is taken.

If the value specified is not equal to “LOC” or “REM”:

- The controller returns “VALUE OUT OF RANGE”.
- No other action is taken.

If the value is “LOC” or “REM”:

- The controller operation mode is changed to LOCAL or REMOTE mode.
- The controller returns “OK”.

Argument	Value	Description
	<i>Mode</i>	String REM sets the controller to REMOTE mode LOC sets the controller to LOCAL mode
See Also	SYSTem:MCONtrol?	

SYSTem:MCONtrol?

Description	Controller REMOTE/LOCAL operation mode query	
Syntax	SYSTem:MCONtrol?	
Remarks	This command returns the controller operation mode.	
Response	Description	
	<i>Value</i>	REM controller is in REMOTE mode LOC controller is in LOCAL mode
See Also	SYSTem:MCONtrol	

SYSTem:SYNTAX

Description	6000 Laser Controller RS-232 syntax compatibility mode set.	
Syntax	SYSTem:SYNTAX <i>Mode</i>	
Remarks	This command is used to turn the 6000 Laser Controller RS-232 syntax compatibility mode ON or OFF. When the compatibility mode is turned ON, the TLB-6800 controller’s response to commands supported by 6000 controller will mimic 6000 controller’s response.	
Argument	Value	Description
	<i>Mode</i>	Integer 0 turns 6000 controller RS-232 syntax compatibility mode OFF 1 turns 6000 controller RS-232 syntax compatibility mode ON

See Also **SYSTem:SYNTAX?**

SYSTem:SYNTAX?

Description 6000 Laser Controller RS-232 syntax compatibility mode query
Syntax **SYSTem:SYNTAX?**

Remarks This command returns the 6000 Laser Controller RS-232 syntax compatibility mode.

Response **Description**
Value 0 turns 6000 controller RS-232 syntax compatibility mode OFF
 1 turns 6000 controller RS-232 syntax compatibility mode ON

See Also **SYSTem:SYNTAX**

SYSTem:LASer:MODEL?

Description Laser head model number query

Syntax **SYSTem:LASer:MODEL?**

Remarks This command returns the model number of the laser head connected to the controller.

Response **Description**
Value String laser head model number

See Also **SYSTem:LASer:SN?**

SYSTem:LASer:SN?

Description Laser head serial number query

Syntax **SYSTem:LASer:SN?**

Remarks This command returns the serial number of the laser head connected to the controller.

Response **Description**
Value String laser head serial number

See Also **SYSTem:LASer:MODEL?**

SYSTem:LASer:REV?

Description Laser head revision number query

Syntax **SYSTem:LASer:REV?**

Remarks This command returns the revision number of the laser head connected to the controller.

Response **Description**
Value String laser head revision number

See Also **SYSTem:LASer:SN?**

SYSTEM:LASer:CALDATE?

Description Laser head calibration date query

Syntax **SYSTEM:LASer:CALDATE?**

Remarks This command returns the calibration date of the laser head connected to the controller.

Response **Description**
Value String laser head calibration date

See Also **SYSTEM:LASer:SN?**

SYSTEM:LASer:WAVElength?

Description Laser diode wavelength query.

Syntax **SYSTEM:LASer:WAVElength?**

Remarks This query returns the laser diode wavelength.

Response **Description**
Value Laser diode wavelength in nanometers (nm)

See Also

SYSTem:LASer:CONDition?**Description** Laser head condition query**Syntax** **SYSTem:LASer:CONDition?****Remarks** This command returns the state of the laser head connected to the controller.**Response Description**

Value *Integer* A 16-bit decimal value representing the state of the laser head connected to the controller.

Bit #	Value	Description
0	0	Soft limit condition not activated
	1	Output current is soft limited
1		Reserved
2		Reserved
3		Reserved
4	0	Rear-panel interlock is grounded
	1	Rear-panel interlock is floating
5	0	Hard limit condition not activated
	1	Output current turned OFF due to hard limit
6		Reserved
7		Reserved
8		Reserved
9	0	Controller temperature is normal
	1	Output current turned OFF due to high controller temperature
10	0	Output current is turned OFF
	1	Output current is turned ON
11	0	Output current ondelay expired
	1	Output current ondelay not expired
12		Reserved
13	0	Laser head disconnected
	1	Laser head connected
14		Reserved
15		Reserved

See Also

6 Principles of Operation

6.1 Theory of Design

Traditional diode-laser technology provides high reliability, high electrical efficiency, and a wide range of available wavelengths in a compact package. By using an external cavity built around a diode laser, the Vantage laser enhances the performance of off-the-shelf diode lasers, guaranteeing single-mode operation with narrow linewidth and precise wavelength tuning. The short-term linewidth of the Vantage laser is <300 kHz (over a 50-msec time interval), compared with typical linewidths for Fabry-Perot diode lasers of 10-500 MHz.

The Vantage laser cavity is based on the Littrow design, which uses a diffraction grating to provide wavelength selectivity. Essential to the high performance of tunable external-cavity diode lasers (ECDLs) is an anti-reflection (AR) coating on the front facet of the diode. The AR coating turns the diode into purely a gain element. A collimating lens directs the output of the diode to a diffraction grating which provides feedback to the diode. Dispersion provided by the grating allows only one cavity mode to lase, resulting in a very narrow linewidth.

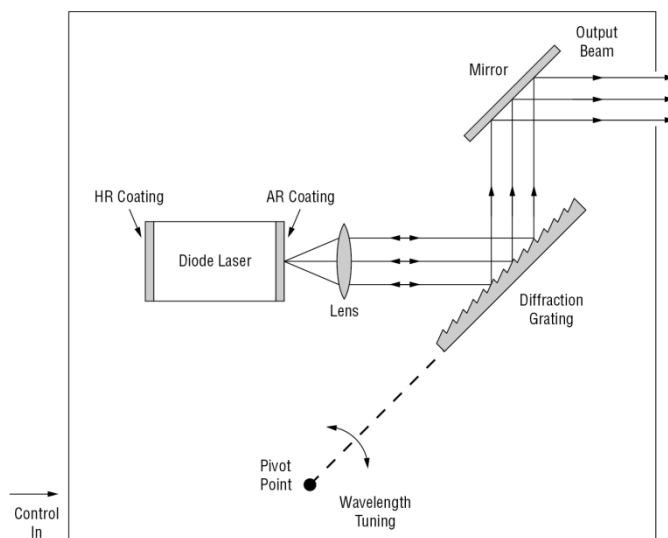

Figure 27 Schematic of the Vantage laser cavity

The TLB-6800-LN controller provides current, voltage, and temperature controls to the laser head as well as manual, and computer controlled input/output interfaces. The low-noise current supply drives the diode in the laser head, controlling the output power. The voltage controller drives the piezo in the laser head, controlling the lasing wavelength. Finally, the temperature control regulates the laser-cavity temperature, providing a stable-output wavelength.

The laser wavelength is also affected by the current through the diode. Changing the diode current affects the refractive index of the diode lasers and therefore, the laser cavity length. The magnitude of the effect is diode dependent, but is typically 25-150 MHz/mA.

6.1.1 References

- [1] M. G. Littman and H. J. Metcalf, "Spectrally narrow pulsed dye laser without beam expander," *Applied Optics*, vol. 17, p. 2224–2227, 1978.
- [2] M. G. Littman, "Single-mode operation of grazing-incidence pulsed dye laser," *Optics Letters*, vol. 3, p. 138–140, 1978.
- [3] K. Liu and M. G. Littman, "Novel geometry for single mode scanning of tunable lasers," *Optics Letters*, vol. 6, p. 117–118, 1981.
- [4] M. G. Littman, "Single-mode pulsed tunable dye laser," *Applied Optics*, vol. 23, p. 4465–4468, 1984.
- [5] K. C. Harvey and C. J. Myatt, "External-cavity diode laser using a grazing-incidence diffraction grating," *Optics Letters*, vol. 16, p. 910–912, 1991.
- [6] T. Day, F. Luecke, and M. Brownell, "Continuously tunable diode lasers," *Lasers and Optronics*, p. 15–17, June 1993.

7 Tips and Techniques

7.1 Introduction

This section explains operational details of the Model TLB-6800-LN Controller and its associated laser head. Application examples are provided.

7.2 Grounding a Laser Head

The TLB-6800-LN Tunable Laser Controller outputs are isolated from earth (chassis) ground. Isolating the laser head case avoids damaging the device from multiple ground loop potentials, AC transients, or static discharge. Since test equipment probes, signal sources, and package mounts are often partially earth grounded, it is often necessary to also bond the device case to earth ground. It is strongly recommended that a single point ground scheme be established, specifically at the binding post. This will help minimize noise, transients, and ground loop hazards. Be sure to include any signal generators in your ground circuit.

	CAUTION
	Only one connection to ground is accepted. Failure to do so may result in the unit malfunction and/or damage. Be careful when connecting other instruments to TLB-7100 Tunable Diode Laser, as they may have their ground connected to the Earth Ground.
	For example, oscilloscopes have the probe ground connected to Earth Ground.

If you have additional questions about your earth grounding method, contact a New Focus applications engineer.

This page is intentionally left blank

8 Maintenance and Service



WARNING

Work performed by persons not authorized by Newport Corporation will void the warranty.

8.1 Enclosure Cleaning



WARNING

Before cleaning the enclosure of the Model TLB-6800-LN Tunable Diode Laser Controller, the AC power cord must be disconnected from the wall socket.

The source enclosure should only be cleaned with a mild soapy water solution applied to a damp lint-free cloth. Do not use an acetone or alcohol solution; this will damage the finish of the enclosure.

8.2 Technical Support

Information and advice about the operation of any New Focus product is available from our technical support engineers. For quickest response, ask for New Focus Technical Support and know the model and serial number for your product.

Hours: 8:00–5:00 PST, Monday through Friday (excluding holidays).

Toll Free: 1-866-NUFOCUS (1-866-683-6287)

(from the USA & Canada only)

Phone: (408) 980-4300

Support is also available by fax and email:

Fax: (408) 919-6083

Email: techsupport@newfocus.com

We typically respond to faxes and email within one business day.

8.3 Obtaining Service

The Vantage Tunable Laser System has been designed to provide years of trouble-free operation with virtually no maintenance except for ensuring that the unit is not damaged, contaminated, or used in an unsafe manner. The TLB-6800-LN Controller contains no user serviceable parts, while the TLB-7100 Vantage laser head is both factory and user serviceable. To obtain information regarding service, contact New Focus or your New Focus representative. Please have the following information available:

1. Instrument model number (on the rear panel).
2. Instrument serial number (on rear panel or bottom of enclosure).
3. Description of the problem.

If the instrument is to be returned to New Focus, you will be given a Return Number, which you should reference in your shipping documents. Please fill out a copy of the service form, located on the following page, and have the information ready when contacting Newport Corporation. Return the completed service form with the instrument.

8.4 Warranty

New Focus, a division of Newport Corp, guarantees its lasers to be free of defects for one year from the date of shipment or for 3000 hours of operation, whichever comes first. This is in lieu of all other guarantees, expressed or implied, and does not cover incidental or consequential loss. The laser head warranty is void if the inner laser cavity box is opened.

8.5 Service Form

New Focus U.S.A.
Office: 408-980-4300
FAX: 408-919-6083

Name _____ Return Authorization # _____
(Please obtain RA# prior to return of item)

Company _____
(Please obtain RA # prior to return of item)

Address _____ Date _____

Country _____ Phone Number _____

P.O. Number _____ FAX Number _____

Item(s) Being Returned:

Model # _____ Serial # _____

Description _____

Reason for return of goods (please list any specific problems):

This page is intentionally left blank

9 Appendix A – Error Messages

9.1 Introduction

The errors generated by the laser controller can be retrieved by pushing the “Menu” button on front-panel of the controller, scrolling to “Errors” menu, and pressing the “Enter” button. These errors can be retrieved by issuing “ERRSTR?” command through USB or RS-232 communication interface also. Some of these errors can be cleared by switching the laser controller OFF and then back ON. If the errors persist, please contact New Focus for assistance.

The descriptions of the returned errors are detailed in the next sections.

9.2 Error Description

A description of error codes and corresponding error strings generated by the TEC Driver is given below:

Error Code	Error String	Description
0	NO ERROR	No error exists in the error buffer
116	SYNTAX ERROR	This error is generated when the instrument receives a command that cannot be processed. Some typical causes: <ul style="list-style-type: none">a. Using ASCII characters outside of a string constant that are not defined by the command language syntax.b. Missing space between a set command and parameter.c. Missing “?” character in case of query
126	WRONG NUM OF PARAMS	This error is generated when the instrument is unable to process a command due to a mismatch between the number of parameters received and the number of parameters required for the command.
201	VALUE OUT OF RANGE	This error is generated when the instrument is unable to process a command because the parameter value received is out of range of the acceptable values for the command.

407	TEC TEMP LIMIT	The temperature control subsystem output has been turned OFF because the TEC temperature has exceeded safe levels. Please allow the laser head to cool down before turning the laser power ON.
424	TEC OVER TEMP	The temperature control subsystem output has been turned OFF because the internal heatsink temperature has exceeded safe levels. Please allow the unit to cool down, and reset the controller by turning it OFF and back ON.
501	LDD INTERLOCK FLT	The Laser Diode Driver subsystem output has been turned OFF because of remote interlock (BNC connector on rear panel) assertion.
502	LDD CURRENT LIMIT	The Laser Diode Driver subsystem output has been turned OFF because of actual current exceeding the current limit set point.
524	LDD OVER TEMP	The Laser Diode Driver subsystem output has been turned OFF because the internal heatsink temperature has exceeded safe levels. Please allow the unit to cool down before turning the output ON again.
804	PIEZO OVER TEMP	The piezo control subsystem setpoint has been changed to 0V because the internal heatsink temperature has exceeded safe levels. Please allow the unit to cool down before changing the piezo setpoint again.
919	LASER DISCONNECTED	This error is generated when user tries to turn the Laser Diode Driver subsystem output ON without having a laser head connected to the controller.
920	LASER EEPROM ERROR	This error is generated when user tries to connect a laser head to the controller using an incompatible cable.
921	LD HEAD ACCESS OFF	This error is generated when user tries to modify select laser head parameters.

**New Focus
Worldwide Headquarters**

3635 Peterson Way
Santa Clara, CA 95054

(In U.S.): 877-835-9620
Tel: 408-980-4300
Fax: 408-919-6083

Internet: sales@newfocus.com



Visit New Focus Online at:
www.newport.com/newfocus

Newport Corporation, Irvine, California; Evry and Beaune-La-Rolande, France have all been certified compliant with ISO 9001 by the British Standards Institution. Mountain View, California is DNV certified.

Printed in U.S.A.