

**VISIBLE WAVELENGTH
HELIUM-NEON LASER SYSTEM
USER'S GUIDE TO OPERATION**

Research Electro-Optics
5505 Airport Boulevard
Boulder, CO 80301
Phone: (303) 938-1960
Fax: (303) 447-3279

LAP-036
Revision F
ECO#
12/04/2011

PREFACE

This User's Guide is designed to assist you in the daily operation and maintenance of your new Helium-Neon (He-Ne) laser system. The information contained within this User's Guide should answer most of your questions concerning the use and operation of this laser system.

This guide contains seven sections:

Section I: UNPACKING

Section II: SAFETY INFORMATION

Section III: INSTALLATION AND OPERATING INSTRUCTIONS

Section IV: BASIC TROUBLESHOOTING

Section V: WARRANTY

Section VI: REGULATORY INFORMATION

Section VII: SYSTEM SPECIFICATIONS

SECTION I UNPACKING

- Inspect the packing container for any damage that may have occurred during shipment.
 - Contact the shipper immediately if the laser or power supply has been damaged during shipping.
 - Packing materials are specifically designed to protect against shipping damage. Please keep this container and reuse if your system needs to be returned to REO for service or evaluation.
- Carefully remove the laser system from the packing container.
 - Inspect for damage including dents, scratches or broken glass within the laser housing.
- Contact REO immediately if the laser or power supply appears to be damaged.

SHIPPING INVENTORY

The equipment included in this shipment should match the packing slip attached to the box. Verify that the correct product was shipped to you by matching the serial number(s) on the packing list. If the shipment is incomplete or if an incorrect item was shipped to you, please notify REO immediately.

This package should contain:

1 – Cylindrical Laser Head

1 – Power supply

2 – Keys

1 – Remote Interlock Connector

1 - Fuse Assembly with Manual Voltage Selector

1 – 115V and/or 230V Power Cord (depending on where your laser was purchased, both cords may be included with your system)

1 – Manual

SECTION II SAFETY INFORMATION

The laser described in this User's Guide has visible light power. This laser is safe to operate provided that the user complies with all safety warnings. It is recommended that all personnel who will operate or be in the vicinity of the laser during operation read and be familiar with this manual as well as be made aware of the following safety warnings.

- Never look directly into the laser light source or at scattering laser light from reflective surfaces. Laser light is hazardous to the eyes. Never sight down the beam into the source.
- Install the laser so that the laser beam is not at eye level.
- Whenever the laser is operating and the beam is not in use, block the beam with the shutter on the output aperture. Avoid direct exposure to the laser beam.
- As a precaution against accidental exposure to either the laser beam or its reflection, operators should wear laser safety glasses designed for this type of laser.
- High voltage is present at all times when the key switch on the control box is in the "on" position.
- Ensure that the laser head is securely connected to the power supply. To prevent faulty operation be sure that the male connector is fully seated in the back of the power supply.
- The power cord and plug are provided with a ground line. To avoid possible shock ensure that the plug is properly connected to a ground point at the electrical connection.
- Do not attempt to open the sealed laser housing or the power supply. The power supply and laser are not user accessible and service operations inside the enclosure must only be performed by authorized and trained personnel. Opening the laser or power supply will result in loss of warranty.
- Do not perform any operating or maintenance procedure that is not described in the user's manual.
- Do not operate this product if the cover has been removed.
- This product is for indoor use only. To prevent potential fire or shock hazard, do not expose the unit to any source of excessive moisture.
- Operating this product in the presence of flammable gases or fumes is extremely hazardous.
- Disconnect power cord before replacing fuses.
- Clean laser head and power supply with dry, soft cloth. Do not use liquids

CAUTION: Use of controls or adjustments or performance of procedures other than those specified herein may result in hazardous radiation exposure. Avoid unnecessary exposure to laser or collateral radiation that exceeds the accessible emission limits listed in the safety regulation guidelines 21 CFR Subchapter J 1040.10 and 1040.11. This federal regulation is administered by the National Center for Devices and Radiological Health under the Food and Drug Administration.

SECTION II SAFETY INFORMATION (CONTINUED)

Each REO Helium-Neon laser system that is certified to be in compliance with the CDRH regulations, is equipped with a key-switch, remote interlock connector, emission indicator, time delay relay (built into the power supply), a beam attenuator (or shutter, located in the front bezel of the laser housing), the front bezel of the laser housing), and all appropriate warning labels.

To ensure continued compliance, verify on an annual basis or, if the product has been subjected to adverse environmental conditions such as fire, flood, mechanical mishandling, or solvent spillage that your systems' safety features listed above are available and operational.



CE COMPLIANCE

For European customers who require a CE approved laser system, REO certifies that our laser heads and lab power supplies meet the appropriate CE requirements. In order for the CE regulations to be met, all REO lab power supplies must be used with an input line cord with a length of less than 3 meters. The factory included line cord has a length of approximately 2 meters. Other cords may be used, but they must have a length of no longer than 3 meters in order for the laser system to remain CE compliant.

SECTION III INSTALLATION AND OPERATING INSTRUCTIONS

The cylindrical construction of the laser head allows for easy mounting in ring clamps, V-blocks, or similar mounting hardware without affecting the laser's alignment. Use caution when clamping onto the laser as too much pressure can damage the aluminum housing or cause misalignment. The front bezel has four each 4-40 Unified National Coarse Thread (UNC) holes to secure an optional accessory mounting ring. The ring (part number 30646), which is available for purchase from REO, has 1" diameter, 32 threads-per-inch (TPI) female threads.

INSTALLATION

- REO's laser system includes a laser head and a power supply. The power supply is not universal and will not operate until the fuse assembly is correctly installed. The fuse assembly can be found with a 250V – 5A slow blow fuse installed. Note: **USE ONLY 250V-5A SLOW BLOW FUSES WITH THIS PRODUCT.** A component needed for this assembly, which is shipped separately, is the input line voltage selector. The input line voltage selector configures the correct input line voltage for the local environment. This can be accomplished by sliding the input line voltage selector into the fuse assembly. Select 115V or 230V based on the requirements of your region of the world. **NOTE: FAILING TO SELECT THE CORRECT INPUT LINE VOLTAGE WILL RESULT IN FAILURE OF THE UNIT AND WILL VOID THE WARRANTY.** Once the correct line voltage is selected, insert the fuse assembly into the power cord connector located on the back of the unit. The fuse assembly will be flush with the face of the AC connector when properly installed. Once the fuse assembly and voltage selector are correctly installed, insert the supplied UL rated, US IEC320 Female to Nema 5-15P power cord into the HCU power unit. To ensure proper and optimal laser operation, only use the HCU power supply that is appropriate for the HeNe laser tube in use.
- Insert the remote interlock connector into the back of the power supply.
- Plug the two prong high voltage cable from the laser into the front of the power supply. Confirm that the plug is well seated.
- Insert the key into the front panel of the power supply.

OPERATION

- Confirm that all connections between the laser and power supply are well seated and/or locked.
- Plug the power cord into an electrical outlet that is confirmed operational.
- Apply power by switching the key to the on (vertical) position. The white emission indicator should glow on the front panel of the power supply indicating power to the power supply.
- Open the beam shutter located on the laser head at the output of the laser (indicated by the arrow on the aperture label)
- The system should start within forty-five seconds and specifications are guaranteed after thirty minutes of operation.

SECTION III (CONTINUED)

INSTALLATION AND OPERATING INSTRUCTIONS

FUSE REPLACEMENT

Disconnect unit from electrical outlet before proceeding. To remove the fuse assembly, insert a flat blade screw driver into the groove on top of the fuse assembly and gently pry it from the power cord connector. Remove the fuse and replace with a 250V – 5 Amp slow blow fuse (Fuse Type 2AG). While replacing the fuse assembly as described above, ensure the input voltage selector is still properly configured.

Before the unit can be operated, follow the steps outlined in the operation section of this manual.

REMOTE INTERLOCK OPERATION

To use the remote interlock connector, remove the shorting conductor from the connector provided. The connector may be then wired into the users interlock system. The circuit is designed to activate the laser output when the two contacts of the connector are shorted together. This can be achieved via a simple switch or with relay contacts.

- The voltage on this connector is 5VDC and is generated internally within the HCU. It is completely isolated from the AC line voltage. Failure of the remote interlock feature due to improper application of external voltages is not covered by warranty.

SECTION IV

BASIC TROUBLESHOOTING

Once the laser and power supply have been properly connected, the REO laser system will operate without maintenance. Below are some guidelines if your system is not operating.

- No emission light above the key switch after key has been turned to the on position -
 - Verify that the power cord is connected to the back of the power supply as well as a verified power source.
 - Verify that the remote interlock is fully engaged in the back panel of the power supply
- No laser emission
 - Verify that the high voltage cable is connected and well seated to the back of the control box
 - Verify the shutter is open
 - If laser does not ignite within one minute switch the control box off, wait several minutes and retry.

NOTE: DO NOT LOOK DIRECTLY INTO THE LASER, EVEN IF NO VISIBLE LIGHT IS BEING EMITTED.

SECTION V WARRANTY INFORMATION

WARRANTY POLICY

REO lasers and power supplies are warranted to be free from defects in materials and workmanship for a period of 12 months from the date of the initial shipment. This warranty does not extend to damage caused by negligent or improper handling in use, storage, or transportation, nor for products from which the original identification markings or labels have been removed, defaced, or altered.

Special contracts or contracts for non-standard products may have modified terms of warranty and, in such cases; the terms as stated in the individual contract must be signed by the duly authorized officer of REO and will supersede the standard terms. REO reserves the right to change our warranty policy without any prior notice. Please contact REO directly with any questions pertaining to your warranty.

REO will make the final determination as to the cause or existence of the defect and, at our discretion, repair or replace the products that prove to be defective during the warranty period. Products replaced under warranty will be warranted only for the balance of the warranty period of the originally supplied equipment.

This warranty extends only to the original purchaser of the equipment from REO, and is not transferable. The purchaser must notify REO within 15 days of first noticing the defect and promptly return the defective product before the expiration of the warranty period. Products returned from persons not employed by the original purchaser will not be evaluated without prior consent from the original buyer.

Products believed by the purchaser to be defective shall be returned to REO. Transportation, insurance, duties, etc., are to be paid by the purchaser. Repaired or replaced products will be returned to the purchaser by REO, F.O.B. city of destination, domestic as well as foreign territories. REO will not be responsible for any duties, levies, taxes, etc., on returned items.

WARRANTY PROCEDURE

Review the terms of your purchase and the date of shipment to determine the validity of your warranty claim. Warranty claims should only be made for products that are within the terms of the warranty policy.

Prior to returning any unit for repair or evaluation, please contact REO either by phone at (303) 938-1960 or by fax at (303) 447-3279 to obtain authorization to return the unit in the form of a Return Authorization number. This number is valid for 30 days for domestic customers, 45 days for foreign customers. If the unit is not received within this time frame, the authorization number will be closed out and you will need to call to obtain a new authorization number. For returns in foreign countries where representation is present, please contact your distributor. For customers in the U.S.A. and

SECTION V
WARRANTY INFORMATION (CONTINUED)

countries where distributorships and/or representation are not available, all claims and correspondence should be addressed to:

Research Electro-Optics
Attn: Laser Service Department
5505 Airport Boulevard
Boulder, Colorado 80301
Ref: Return Authorization Number

Please be prepared to furnish the following information when requesting an authorization number:

- a. Product model number and serial number
- b. Date of shipment/purchase
- c. Brief description of problem/failure
- d. Name and phone number of contact person at your organization.

Obtain REO instructions for transportation and packaging, and ship the product (freight and insurance prepaid) with the proper documentation containing the authorization number and the information specified above. Please ensure the authorization number is visible on the front of the shipping container.

REO will advise the purchaser of its evaluation results at the earliest possible time. Providing complete information as requested will help to expedite this process. For products outside of their warranty period, an evaluation will be made at no charge and a cost estimate for repair/replacement will be issued. Only after receiving authorization (in the form of a Purchase Order) will any repair/replacement work be performed. Charges for repair work will be billed at the current repair rate (available upon request from REO) plus the cost of any additional required parts. Repair work will be warranted for a period of 6 months from the date of shipment.

SECTION VI REGULATORY INFORMATION

REO WEEE POSITION STATEMENT

REO is committed to meeting the requirements of the European Union (EU) Waste Electrical and Electronic Equipment (WEEE) Directive. This Directive requires producers of electrical and electronic equipment to finance the takeback, for reuse or recycling, of their products placed on the EU market after August 13, 2005.

REO products that are within the scope of the Directive are labeled with a crossed out "wheelie-bin" symbol, as required by the Directive. It indicates that the product was placed on the market after August 13, 2005 and that end users should segregate the product from other waste at end-of-life.

The WEEE Directive is being implemented in each of the 27 EU countries through national legislation. Norway and Switzerland have also implemented similar pieces of legislation. As a result, the detailed requirements vary considerably throughout the EU, and REO WEEE compliance approach varies among countries.

For All REO HeNe laser systems, HeNe laser heads and HeNe power supplies sold after August 13, 2005 REO offers a product takeback service to its business customers. If you wish to return an REO unit for waste recovery, please contact REO.

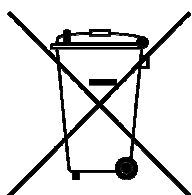

SECTION VII LASER SPECIFICATIONS

The following page(s) contain detailed information concerning your specific laser system. Please feel free to contact the laser department at REO if you have any questions concerning your laser system. REO can be reached at (303) 938-1960 or by fax at (303) 447-3279.

TECHNICAL DATA
R-30972
CYLINDRICAL HELIUM-NEON LASER HEAD

Wavelength	543 nm
Minimum Output Power	2.0 mW
Power 3 Seconds After Turn-On	> 75%
Polarization	Random
Mode Structure	TEM ₀₀ > 99%
Beam Diameter	0.83 mm
Beam Divergence	0.84 mrad
Longitudinal Mode Spacing	303 MHz
Beam Drift After 20 Minute Warm-Up	< 0.2 mrad
Long Term Beam Drift	< 0.05 mrad
Noise (30 Hz - 10 MHz)	< 1% rms
Starting Voltage	< 10 kVDC
Operating Voltage	3100 VDC
Series Resistors in Housing	94 KΩ
Operating Current	5.25 mA
Shock	15 g for 11 msec
Weight	750 grams
Dimensions	
Length	533.4±1.0 mm (21.00±0.04")
Diameter	44.2±0.5 mm (1.74±0.02")
Maximum Output Power	5.0 mW
CDRH Classification	IIIa
CE Classification	3R
Recommended Power Supply	32881

ENVIRONMENTAL SPECIFICATIONS

Temperature	<u>Operating</u> -20 - +70° C	<u>Non-Operating</u> -40 - +80° C
Humidity	≤ 80%	≤ 95%
Altitude	0-3,000 meters	0-6,000 meters

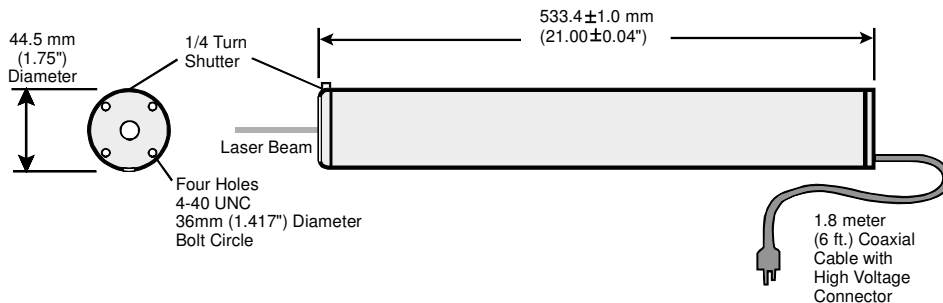

Research Electro Optics, Inc.
5505 Airport Boulevard Boulder, Colorado 80301
 Phone - (303) 938-1960 Fax - (303) 447-3279

Operating Instruction for HCU Power Supplies

HeNe Control Unit Series Power Supplies (39783, 39784, 39785, 39786)

Introduction

The HCU is a turn-key power supply for HeNe laser tubes that incorporates all of the appropriate safety features required by US Federal regulations. This unit is RoHS compliant.

Installation

The HCU will not operate until the fuse assembly is correctly installed. (See Fig 1) The enclosed fuse assembly can be found with a 250V - 5A slow blow fuse installed. Note: USE ONLY 250V-5A SLOW BLOW FUSES WITH THIS PRODUCT. A component within this fuse assembly is the input line voltage selector. The input line voltage selector configures the correct input line voltage for the local environment. This can be accomplished by sliding the input line voltage selector into the side of the fuse assembly. The desired input line voltage can be seen right side up in the window on the face of the fuse assembly. See Figure 1 for the proper voltage selection for your region of the world.

NOTE: FAILING TO SELECT THE CORRECT INPUT LINE VOLTAGE WILL RESULT IN FAILURE OF THE UNIT AND WILL VOID THE WARRANTY. Once the correct line voltage is selected, insert the fuse assembly into the power cord connector located on the back of the unit. The fuse assembly will be flush with the face of the AC connector when properly installed. Once the fuse assembly and voltage selector are correctly installed, insert the supplied UL rated, US IEC320 Female to Nema 5-15P power cord into the HCU power unit. Note: Non-US power cables must be supplied by the user.

To ensure proper and optimal laser operation, only use the HCU power supply that is appropriate for the HeNe laser tube in use.

Fuse Replacement:

To remove the fuse assembly, insert a flat blade screw driver into the groove on top of the fuse assembly and gently pry it from the power cord connector. Remove the fuse and replace with a 250V - 5 Amp slow blow fuse (Fuse Type 2AG). While replacing the fuse assembly as described above, ensure that the input voltage selector is still properly configured.

Before the unit can be operated, the laser tube must be connected to the HCU power supply. Do so by inserting the high voltage connector from the HeNe laser tube into the corresponding high voltage connector of the power supply. Check for proper orientation of the high voltage connector. It is polarized and will only fit when properly oriented. Insert the connector firmly and fully into the HCU power supply. Failure to fully engage this connector could result in poor laser operation and damage to both high voltage connectors.

Remote Interlock Operation

To use the remote interlock connector, remove the shorting conductor from the connector provided. The connector may then be wired into the users interlock system. The circuit is designed to activate the laser output when the two contacts of the connector are shorted together. This can be achieved via a simple switch or with relay contacts.

The voltage on this connector is 5VDC and is generated internally within the HCU. It is completely isolated from the AC line voltage. Failure of the remote interlock feature due to improper application of external voltages is not covered by warranty.

Operating Procedures

The system is equipped with a key switch located on the front panel. This is used by the customer to activate and deactivate the laser. A 5-second delay will begin after the key switch is turned to the 'ON' position. The emissions indicator on the front panel will come on to warn of eminent laser emission. The laser system will be 'OFF' when the key is in the vertical position.

The laser emissions can be controlled from the remote interlock connector. If the factory supplied remote interlock plug is removed while the laser is in operation, laser emissions will cease immediately. If the remote interlock plug is inserted into the remote interlock connector, laser emissions will resume after a 3-5 second safety delay. If the remote interlock connector has been interfaced to external circuits, laser emissions will be controlled in an identical manner.

Caution: Use of controls or adjustment or performance of procedures other than those specified herein may result in hazardous radiation exposure.

Figure 1

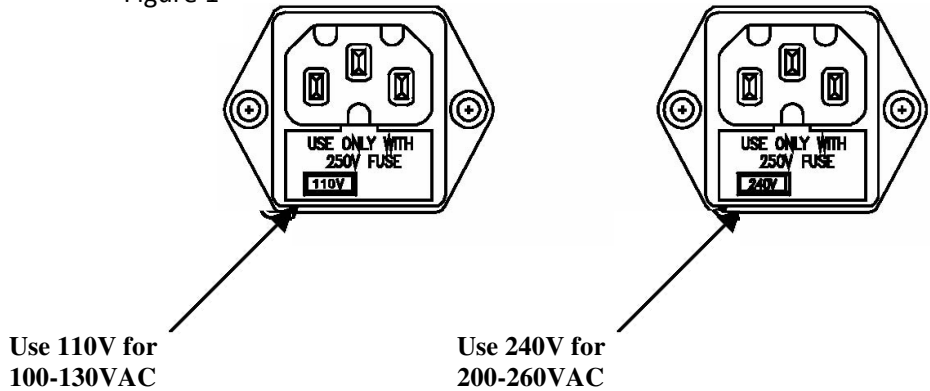

Figure 2

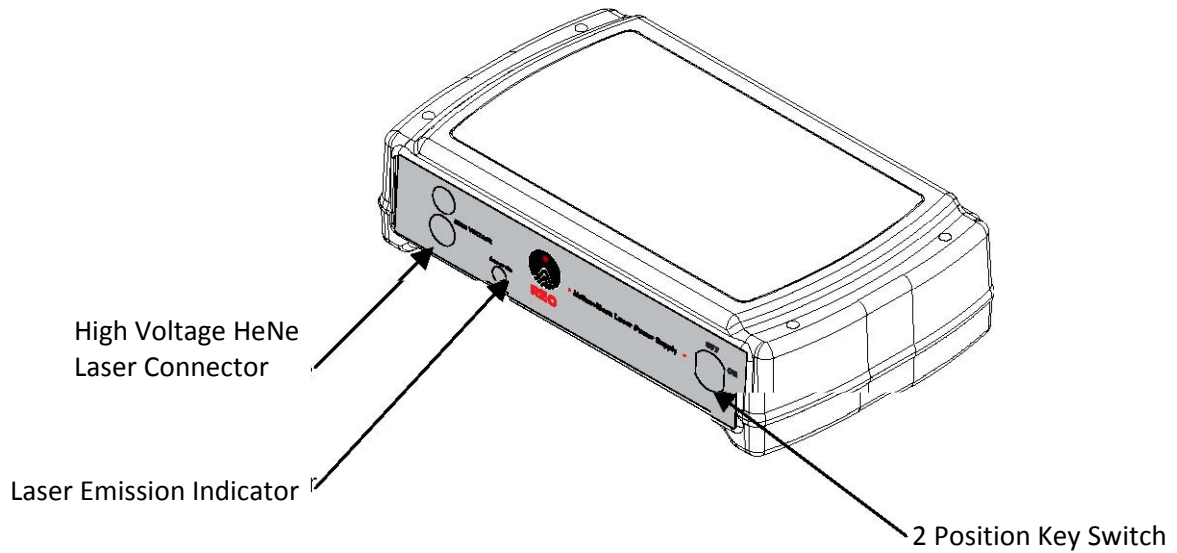
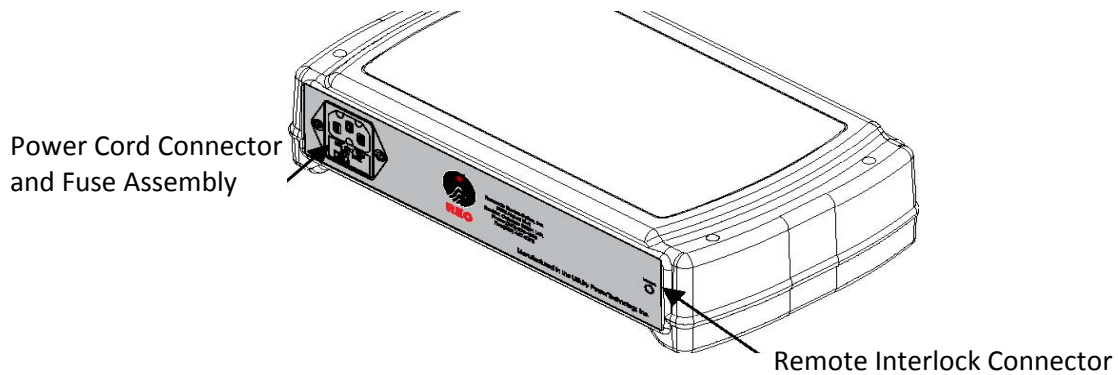

Figure 3



Maintenance & Service

The HCU power supply contain no user servicable parts. Return the HCU to REO for service.

Warranty

Unless otherwise noted, PTI warrants products to be free of defect in workmanship and material for a period of twelve (12) months from the date of shipment. The customer must make all claims under these warranties, and no claim will be accepted from a third party. Warranties are non-transferable. PTI will repair or replace product, provided customer notifies PTI of defect within warranty period and pre-authorizes return of product as outlined in "Returns" section above. Any product repaired or replaced under warranty is only warranted for the period of time remaining in the original warranty for the product. All repairs are warranted for a period of ninety (90) days. PTI's liability is limited to the replacement cost of product. PTI is not responsible for consequential damages.

Power Cord Connector and Fuse Assembly

Remote Interlock Connector



Newport Addendum to REO Laser User Documentation

The information in this document supersedes information contained in the Research Electro Optics, Inc. documentation supplied with your laser.

NOTE

The REO Model 3xxxx-Series lasers are intended for use in an industrial laboratory environment. Use of these products in other environments, such as residential, may result in electromagnetic compatibility difficulties due to conducted as well as radiated disturbances.

NOTE

The REO Model 3xxxx-Series lasers are designed to operate in a controlled electromagnetic environment; i.e., where R.F. transmitters such as mobile telephones may not be used in close proximity.

WASTE ELECTRICAL AND ELECTRONIC EQUIPMENT (WEEE)



This symbol on the product or on its packaging indicates that this product must not be disposed of with regular waste. Instead, it is the user responsibility to dispose of waste equipment according to the local laws. The separate collection and recycling of the waste equipment at the time of disposal will help to conserve natural resources and ensure that it is recycled in a manner that protects human health and the environment. For information about where the user can drop off the waste equipment for recycling, please contact your local Newport Corporation representative.

EUROPEAN UNION CE MARK



The presence of the CE Mark on a product means that this instrument has been designed, tested and certified compliant to all applicable European Union (CE) regulations and recommendations.

Newport Addendum to REO Laser User Documentation

EU Declaration of Conformity

We declare that the accompanying product, identified with the **CE** mark, complies with requirements of the Electromagnetic Compatibility Directive, 2004/108/EC and the Low Voltage Directive 2006/95/EC.

Model Numbers: 3xxxx Series Non-Stabilized HeNe LASERS

Year CE mark affixed: 2012

Type of Equipment: Electrical equipment for measurement, control and laboratory use in industrial locations.

Manufacturer: Research Electro-Optics, Inc
5505 Airport Blvd.
Boulder, CO., 80301
United States of America

Importer: Newport Corporation
1791 Deere Avenue
Irvine, CA 92606
United States of America

Standards Applied:

Compliance was demonstrated to the following standards to the extent applicable:

BS EN61326-1: 2006 “Electrical equipment for measurement, control and laboratory use – EMC requirements” (Laboratory)

This equipment meets the CISPR 11:2009+A1:2010 Class A Group 1 radiated and conducted emission limits.

BS EN 61010-1:2010, “Safety requirements for electrical equipment for measurement, control and laboratory use”.



Brian P. Turner
Laser Process Engineer
Research Electro-Optics, Inc.
5505 Airport Blvd, Boulder, CO 80301 USA



Mark Carroll
Sr. Director, Instruments Business
Newport Corporation
1791 Deere Ave, Irvine, CA 92606 USA

Newport Addendum to REO Laser User Documentation

Confidentiality & Proprietary Rights

Reservation of Title:

The Newport programs and all materials furnished or produced in connection with them ("Related Materials") contain trade secrets of Newport and are for use only in the manner expressly permitted. Newport claims and reserves all rights and benefits afforded under law in the Programs provided by Newport Corporation.

Newport shall retain full ownership of Intellectual Property Rights in and to all development, process, align or assembly technologies developed and other derivative work that may be developed by Newport. Customer shall not challenge, or cause any third party to challenge the rights of Newport.

Preservation of Secrecy and Confidentiality and Restrictions to Access:

Customer shall protect the Newport Programs and Related Materials as trade secrets of Newport, and shall devote its best efforts to ensure that all its personnel protect the Newport Programs as trade secrets of Newport Corporation. Customer shall not at any time disclose Newport's trade secrets to any other person, firm, organization, or employee that does not need (consistent with Customer's right of use hereunder) to obtain access to the Newport Programs and Related Materials. These restrictions shall not apply to information (1) generally known to the public or obtainable from public sources; (2) readily apparent from the keyboard operations, visual display, or output reports of the Programs; 3) previously in the possession of Customer or subsequently developed or acquired without reliance on the Newport Programs; or (4) approved by Newport for release without restriction.

Trademarks

The Newport logo is a registered trademark of Newport Corporation in Austria, Barbados, Benelux, Canada, the People's Republic of China, Denmark, France, Germany, Great Britain, Ireland, Japan, the Republic of Korea, Spain, Sweden, and the United States. Newport is a registered trademark of Newport Corporation in Austria, Barbados, Benelux, the People's Republic of China, Denmark, France, Germany, Ireland, Japan, the Republic of Korea, Spain, and Sweden.

Service Information

This section contains information regarding factory service for the source. The user should not attempt any maintenance or service of the system or optional equipment beyond the procedures outlined in this manual. Any problem that cannot be resolved should be referred to Newport Corporation.