

SM300-SC and SM400-SC Pure Silica Core Fiber

Singlemode UV / short λ visible light delivery for biotechnology, fluorescence spectroscopy and LDA

Singlemode delivery, both in the UV and at the shorter visible wavelengths has always been problematic – even when fibers with suitably short cut-off wavelengths are available, the intrinsic photodarkening suffered by their germania-doped cores soon renders them useless.

Pure Silica Core – Negligible Photodarkening above 450 nm AND higher nonlinear and thermal damage thresholds

Unlike conventional fibers, Fibercore SM300-SC and SM400-SC have been designed with an un-doped, pure-silica core, surrounded by a depressed, fluorine-doped cladding. Without germania (GeO_2), electronic defects and consequent colour-centres associated with the Ge-O bond, the prime cause of photodarkening, are dramatically reduced with the result that power handling capacity in the blue is increased from a few milliwatts to several watts. In fact, within the short wavelength region of the visible spectrum, the transmission-limiting mechanism is effectively shifted from photodarkening to other nonlinearities (eg stimulated scattering) or even thermal damage – and in both cases, these limits too are increased over those of a conventional germano-silicate fiber.

These fibers will still exhibit some degree of photodarkening in the UV, but their performance in this respect is dramatically better than that of singlemode fibers with conventional Ge-doped cores.

SM300-SC and SM400-SC – Effective Singlemode Transmission from 305 nm to 532 nm

In order to ensure strong guidance throughout the design spectrum, two ‘SC’ fibers are available: SM300-SC for use at wavelengths between 305 nm and 450 nm, and SM400-SC for 405 nm to 532 nm. Their standard numerical aperture of 0.13 guarantees better than 0.1 dB/m coiled to 60 mm diameter even at the far extremes of these ranges, making the fibers ideal for most ‘probe-type’ applications.

NEW! SM-SC Pure Silica Core Fiber

- Two variants SM300SC (305 – 450 nm) and SM400SC (405 – 532 nm)
- Biotechnology
- Fluorescence Spectroscopy
- Laser Doppler Anemometry
- Laser Doppler Velocimetry
- Analytical Applications

Fluorinated, depressed-clad design – exceptional power-handling capabilities in the UV and Short λ visible

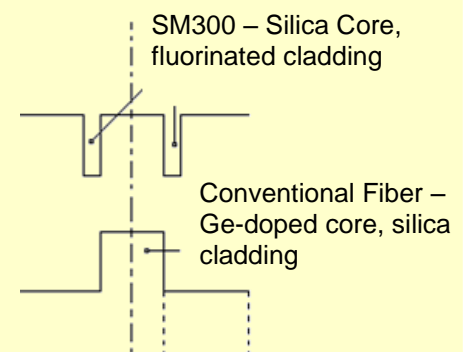

Low short-wavelength attenuation that stays low – over time, even at high powers

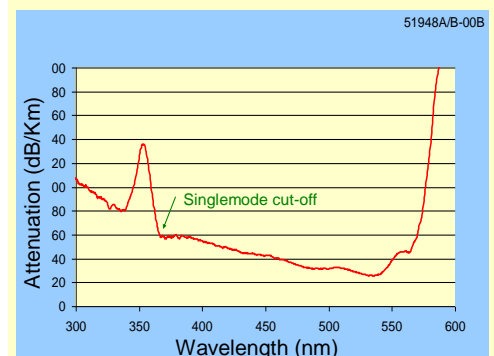

Notes

SM300-SC and SM400-SC may also be suitable for probes transmitting blue and red wavelengths respectively, depending on deployment conditions (bend-diameters, cable design, connector quality etc). These applications should be assessed on a case-by-case basis and are also likely to be dependent on the exact cut-off and NA specifications of available production lots. So if you would like to explore the capabilities of SM300-SC or SM400-SC beyond their design wavelengths, please contact Fibercore Limited, or your local representative, for a free-of-charge, three metre sample.

Specifications

	SM300-SC	SM400-SC
Operating Wavelength λ_{op} (nm)	305 - 450	405 - 532
Cut-off Wavelength (nm)	< 300	305 - 400
Numerical Aperture	0.12 - 0.14	
MFD (μm) @ λ_{op} nominal	1.9 – 3.0	2.5 – 3.4
Attenuation (dB/km) @ λ_{op}	< 70 dB/km (350 nm) < 100 dB/km (450 nm)	< 50 dB/km (430 nm) < 30 dB/km (532 nm)
Fiber Diameter (μm)	125 \pm 1	
Core Cladding Concentricity (μm)	\leq 0.75	
Coating Diameter (μm)	245 \pm 5%	
Coating Type	Dual Acrylate	
Proof Test	1% (100 kpsi)	