

Model 5540 User's Manual

**The Berek Polarization
Compensator**

Patent # 5,245,478



Warranty

New Focus, Inc. guarantees its products to be free of defects for one year from the date of shipment. This is in lieu of all other guarantees, expressed or implied, and does not cover incidental or consequential loss.

Contents

Warranty	2
Introduction	3
Theory	4
Operation	8
Applications	14
Appendix 1: Determining Compensator Settings for Arbitrary Input and Output States	16
Specifications	19
References	20

Introduction

The Model 5540 Berek polarization compensator* can convert the polarization of a collimated laser beam from any state to any other state with the flexibility and precision previously characteristic only of expensive and lossy Soleil-Babinet compensators. Used as a variable waveplate, the Berek compensator can impose 1/4-wave or 1/2-wave retardance at any wavelength between 200 nm and 1600 nm. This dramatically reduces the number of different plates necessary in the laboratory. The Model 5540 polarization compensator can fit in a variety of 2" mirror mounts, or you can mount it directly to a post. With its 12-mm aperture, this compensator will accept beams from almost any commercially available laser system.

* Patent Pending

Invented in 1913¹, the Berek polarization compensator has long been used in microscopy and other technical applications. It consists of a single plate of a uniaxial material with its extraordinary axis perpendicular to the plate. Therefore, when light is at normal incidence to the plate, it propagates through the device with a velocity independent of polarization. It sees an isotropic material in this configuration, and the Berek polarization compensator has no effect on its polarization. However, when the plate is tilted with respect to the direction of the incident light, the plane of incidence becomes the plane of the extraordinary index of refraction. Light polarized in this plane propagates at a different velocity. The wave is slowed or retarded by an amount that depends on the angle of tilt and on the wavelength. Light in the polarization perpendicular to the plane of incidence continues to propagate as an ordinary wave with velocity independent of tilt angle. Thus, the light in the two planes of polarization accumulates a relative phase shift or retardance. For example, Fig. 1 shows the slow axis being retarded by 90° relative to the fast axis resulting in linearly polarized light being converted to circularly polarized light when the device is oriented at 0° .

Fig. 1

Conversion of linearly polarized to circularly polarized light.

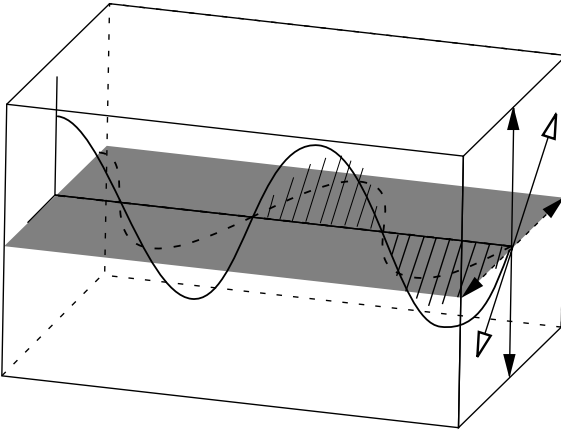

A. Linearly polarized light at the input of the Berek compensator

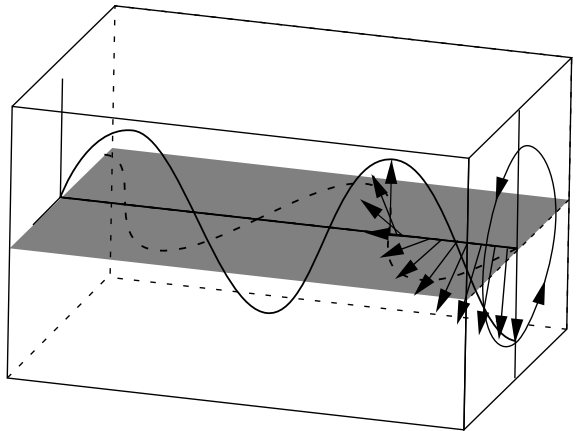

B. Circular polarization at the output of the Berek compensator when the retardance is tuned to 90°

The Model 5540 Berek compensator* allows the retardance and the orientation of the plane of incidence to be adjusted conveniently and independently using two knurled rings, one on each end of the housing. Once the tilt angle is set correctly with the “Retardation” knob, rotating the housing with the “Orientation” knob rotates the variable wave plate just like a conventional compensator or retarder. Precision scales allow both tilt angle and orientation angle to be set accurately. The axis of rotation for the plane of incidence can be conveniently set parallel to the propagation direction using a conventional optic mount.

Near normal incidence the retardance increases quadratically with tilt angle allowing very precise compensation of small phase shifts due to other optical elements. Fig. 2a shows the actual retardance versus the “Retardation” indicator setting for the New Focus Berek compensator at 488 nm, 632.8 nm, and 1060 nm. Fig. 2b shows “Retardation” indicator setting versus wavelength to achieve precise $\lambda/2$ and $\lambda/4$ retardance.

For an in-depth discussion on calculating these curves see Appendix 1. It contains the equations necessary to determine the actual retardance required to convert an arbitrary input polarization state into a specified output polarization state. It also contains both the exact expression for actual retardance versus “Retardation” indicator setting and the relationship between tilt angle and “Retardation” indicator setting.

* Patent Pending

Fig. 2a

Retardance (in waves) versus indicator setting for the New Focus Berek compensator at 488 nm, 632.8 nm, and 1060 nm.

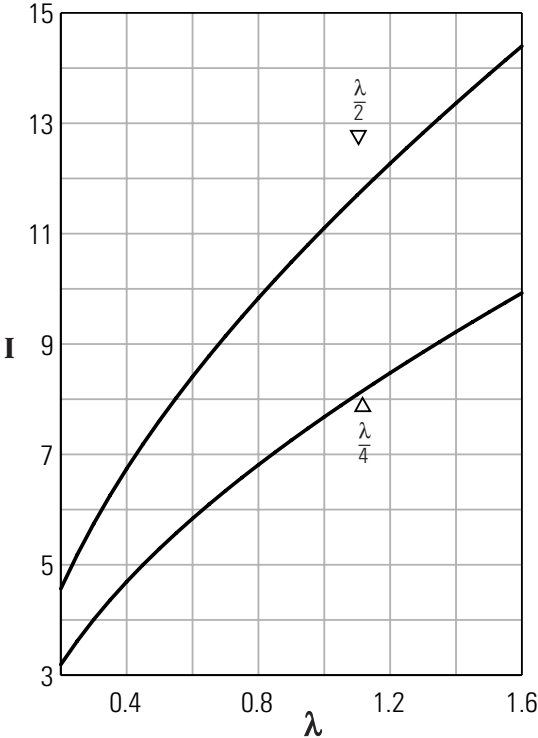
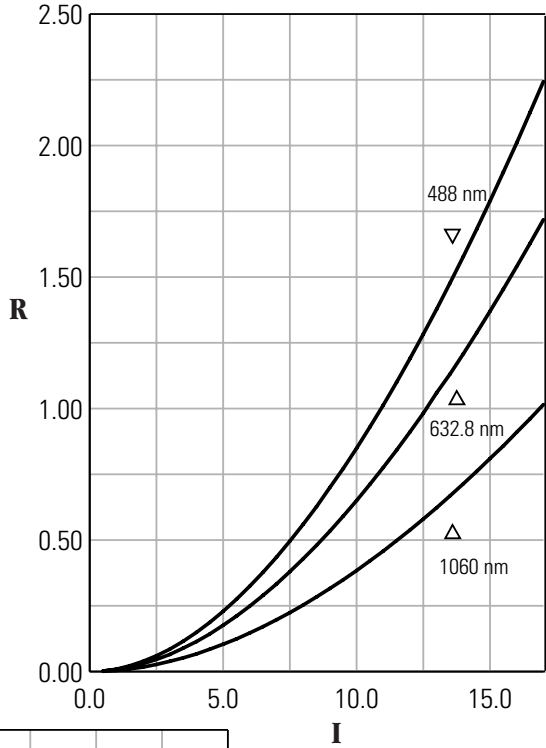

Fig. 2b

Indicator setting versus wavelength for $\lambda/2$ and $\lambda/4$ retardance.

NOTE: Please see Appendix 1 for the relationship between tilt angle and “Retardation” indicator setting.

Operation

1) **Initial alignment:** (Fig. 3) Set the “Retardation” indicator on the Model 5540 Berek compensator to zero (this also sets the tilt angle to zero). Place the compensator in your setup making sure that the collimated laser beam is centered on the 12-mm diameter aperture. (We recommend mounting the Model 5540 in a gimbal-type mirror mount such as the Model 9852 shown in Fig. 3.) The compensator housing should be mounted such that the “0” on the “Orientation” indicator is at a convenient angle. Now, leaving the “Retardation” indicator set to “0”, use the two tilt controls of the mirror mount to align the compensator so that it is normal to the propagation direction of the light by finding the reflection from the compensator plate and forcing it to propagate back along the direction of the incident beam.

When the compensator is properly aligned and the “Retardation” indicator is set to “0”, the reflected beam will not move away from the incident beam direction when the compensator is rotated around its axis. The compensator is rotated by turning the “Orientation” knurled ring. When the initial alignment has been done properly, the polarization compensator transmits the incident polarization unchanged, whatever the orientation angle.

NOTE: The indicator setting for “Retardation” is NOT the actual value of the tilt angle. See Appendix 1 for the relationship between “Retardation” indicator setting and tilt angle.

Fig. 3

Initial alignment of the Berek compensator.



Patent # 5,245,478

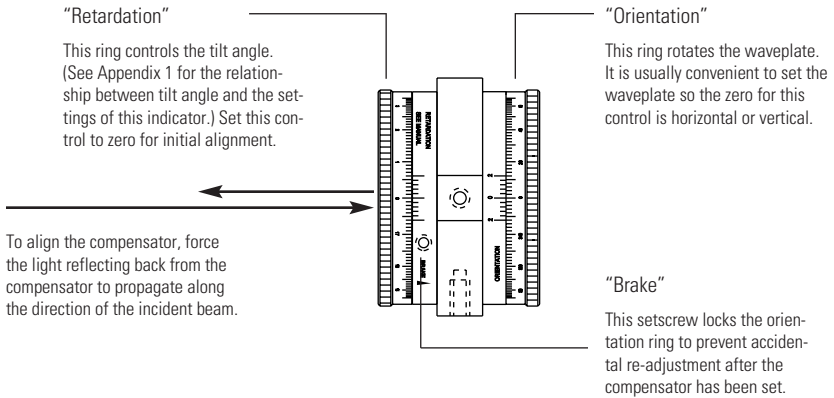

2) **Setting the actual retardance:** The “Retardation” indicator controls the compensator plate tilt angle and hence the actual retardance value. Setting the “Retardation” indicator to “0” gives zero tilt and zero retardance. At nonzero values, the Berek polarization compensator can be set to either a single-order or a multiple-order waveplate. The smaller the retardance, the more accurately it can be set. To a good approximation, the tilt angle θ_R that gives retardance R (in waves) is

$$\theta_R \cong \sin^{-1}(0.284\sqrt{\lambda R})$$

where λ is the wavelength in microns.

The “Retardation” indicator setting (I) is related to the tilt angle by

$$I = 50.22 - 71 \sin\left(\frac{\pi}{4} - \theta_R\right).$$

Approximate “Retardation” indicator settings can be read from Fig. 2a. More accurate values can be obtained using the formulas in Appendix 1. When setting the “Retardation,” make sure that the entire compensator housing (and therefore the orientation angle) does not rotate.

3) **Setting the orientation angle:** The knurled ring marked “Orientation” rotates the entire housing to properly orient the slow axis of the compensator plate with respect to the incident polarization. If the compensator has been mounted with the “0” on the orientation scale vertical, one can read the orientation angle directly. To make circular polarization from linear polarization, one must set the retardance to $1/4$ wave and the orientation angle to the incident linear polarization direction plus 45° . If the retardance is set to $1/2$ wave, a 45° orientation angle will rotate the plane of polarization by 90° . In general, a $\lambda/2$ -wave plate rotation causes the plane of polarization to rotate by twice the orientation angle.

After adjusting the orientation angle, it may be convenient to lock the orientation adjustment ring. This can be done by tightening the set screw marked “Brake” on the ring itself. (See Fig. 3.)

4) **Verifying the output polarization:** When using a waveplate, one should always verify that it has produced the desired polarization. There are various methods, some of extreme precision.

A) Since **linear polarization** can be blocked to better than 0.01% with a calcite polarizer, it is easy to verify that the output of the Model 5540 Berek polarization compensator is linear and oriented properly. Simply place a calcite polarizer, such as a Model 5521 or 5523, after it and orient the polarizer to block the desired output polarization. Both the tilt angle (see “Setting the retardance.” pg. 10) and orientation angle of the compensator can be adjusted to fine-tune the polarization. At this stage, do not use the mounting to adjust the tilt of the compensator housing.

If the laser beam is not perfectly collimated, you may see a narrow absolutely dark line through the center of a very dim beam transmitted through the polarizer. If too much light is transmitted through the polarizer, even when tilt and orientation have been optimized, consider reducing the retardance by one full wave or improving the collimation. The smaller the retardance, the less sensitive is the polarization to imperfect collimation due to the angular dependence of the birefringence.

- B) To verify **circular polarization**, reflect the output light back through the compensator. The polarization of the wave that goes through the compensator twice will be exactly orthogonal to the incident polarization for the circularly-polarized light. If the incident polarization is linear, this can best be achieved by setting a calcite polarizer in front of the Model 5540 polarization compensator oriented to transmit the incident beam perfectly. If the compensator is set to produce perfect circular polarization, the reflected wave should be blocked by the calcite polarizer to 0.01%. Slight adjustments to the compensator “Orientation” and “Retardation” (and hence to the tilt angle) can improve the purity of the circular polarization and reduce the transmitted intensity in this test. For best precision, the plane containing the forward and backward propagating beams must be orthogonal to the plane of incidence of the incident beam on the tilt plate.
- C) To verify **elliptical polarization**, you must measure the major and minor axes of the polarization ellipse, or use a second compensator as is found in an ellipsometer. Special cases (such as produced by $N/2$ waves of retardance, where N is an integer) can be verified in a way similar to circular polarization, but with the light making N passes through the compensator plate.

Applications

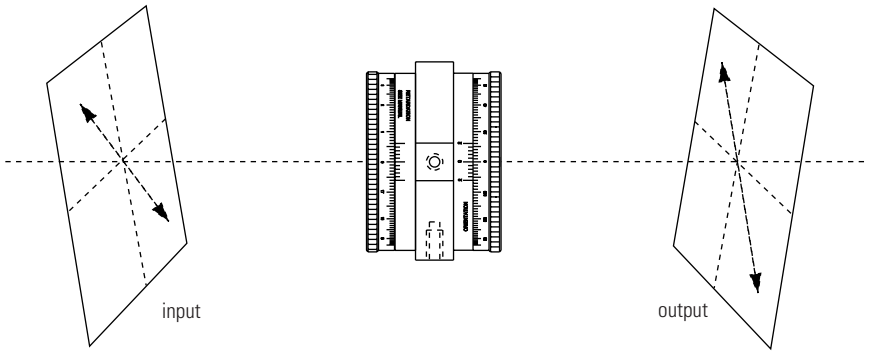

The Model 5540 polarization compensator can be used as a 1/2-wave plate to rotate the plane of polarization of a linearly-polarized laser beam.

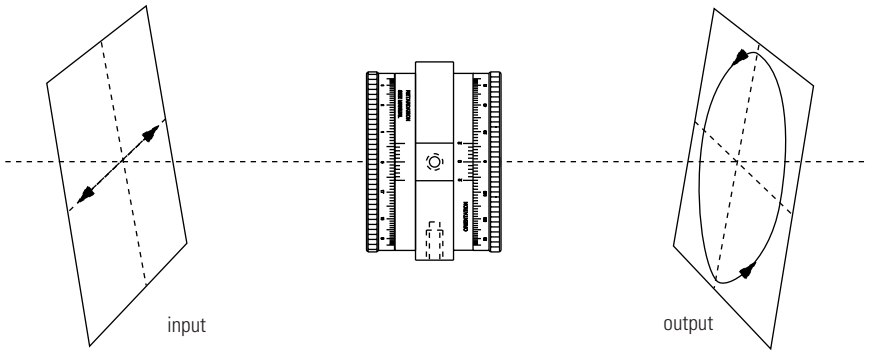

It can be used as a 1/4-wave plate to make a plane polarized laser beam circularly polarized. When used with a linear polarizer this will provide isolation which protects the laser from feedback.

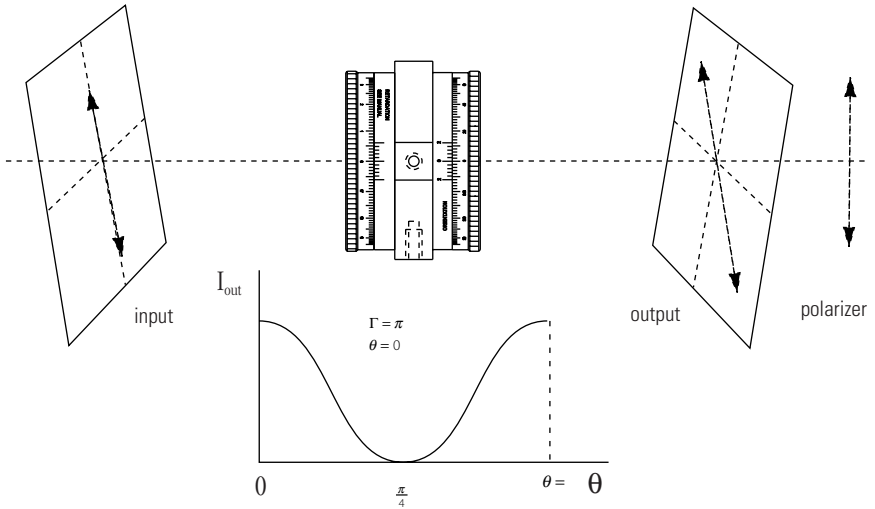

By placing a linear polarizer after the Berek compensator, one can conveniently vary the attenuation of a beam without changing its polarization.

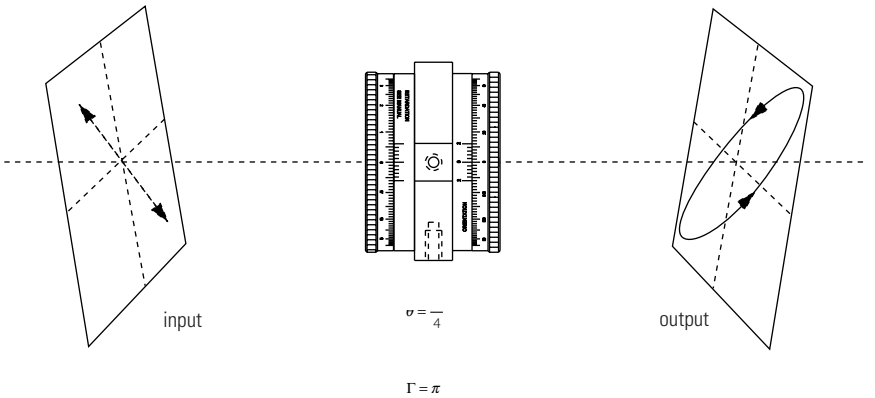

By varying the retardance and orientation, one can produce arbitrary states of elliptical polarization which is especially useful in spectroscopy.

Appendix 1

Determining Compensator Settings for Arbitrary Input and Output States.

The most general application which uses a compensator is one in which the input and desired output polarization states are known and the compensator settings need to be determined. The actual desired retardance and orientation angle can be determined in a straightforward manner by first defining the input and output states in terms of the ellipticity (ϵ =minor axis a /major axis b) and the orientation α of the major axis in the lab frame.

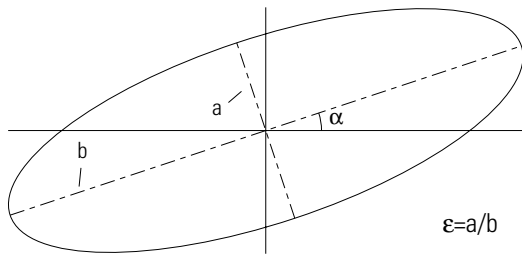

Arbitrary elliptically polarized light can be defined in terms of ϵ (the ratio of the minor to the major axis) and α the orientation of the ellipse.

From these parameters the retardance and orientation can be determined using the equations associated with the Poincaré sphere:

$$\begin{aligned}
 A_1 &= 2\alpha_1 & A_2 &= 2\alpha_2 \\
 E_1 &= 2 \tan^{-1} \epsilon_1 & E_2 &= 2 \tan^{-1} \epsilon_2 \\
 x_1 &= \cos A_1 \cos E_1 & x_2 &= \cos A_2 \cos E_2 \\
 y_1 &= \sin A_1 \cos E_1 & y_2 &= \sin A_2 \cos E_2
 \end{aligned}$$

$$k = -\tan^{-1} \left(\frac{x_2 - x_1}{y_2 - y_1} \right)$$

$$L = \sqrt{(x_2 - x_1)^2 + (y_2 - y_1)^2}$$

$$I_1 = \cos A_1 \sin(k - A_1)$$

$$h_1 = \sin E_1$$

$$h_2 = \sin E_2$$

$$I_2 = \sqrt{h_1^2 + I_1^2}$$

$$M = \sqrt{L^2 + (h_2 - h_1)^2}$$

$$\Gamma = 2 \sin^{-1} \left(\frac{M}{2I_2} \right)$$

The solutions to these equations can then be used to determine the actual retardance (R) and orientation (Z).

$$R = \frac{\Gamma}{2\pi} \quad Z = 0.5k$$

These results are completely general and can be used to determine the settings to convert any input polarization into any output polarization assuming the states can be defined in terms of their ellipticity and orientation.

The relationship between retardance (R) and tilt angle can be determined from the angular dependence of the birefringence in MgF_2 . The extraordinary index of refraction, as seen by the optical beam, is given by

$$\frac{1}{N_e^2} = \frac{\cos^2 \theta_R}{n_o^2} + \frac{\sin^2 \theta_R}{n_e^2}$$

where θ_R is the tilt angle and n_o and n_e are the

indices of refraction. These are, in general, wave-length dependent and their dispersion relations are given by²

$$n_o = \sqrt{1 + \frac{0.4876\lambda^2}{\{\lambda^2 - 0.0434^2\}} + \frac{0.3988\lambda^2}{\{\lambda^2 - 0.0946^2\}} + \frac{2.3120\lambda^2}{\{\lambda^2 - 23.7936^2\}}}$$

$$n_e = \sqrt{1 + \frac{0.4134\lambda^2}{\{\lambda^2 - 0.0368^2\}} + \frac{0.5050\lambda^2}{\{\lambda^2 - 0.0908^2\}} + \frac{2.4905\lambda^2}{\{\lambda^2 - 23.7720^2\}}}$$

Thus, the retardance R (in waves) is related to the tilt angle by

$$R = \frac{2000}{\lambda} \sqrt{n_o^2 - \sin^2 \theta_R} \left\{ \sqrt{\frac{1 - n_e^{-2} \sin^2 \theta_R}{1 - n_o^{-2} \sin^2 \theta_R}} - 1 \right\}$$

The relationship between tilt angle (θ_R) and “Retardation” indicator setting (I) is given by

$$\theta_R = \frac{\pi}{4} - \sin^{-1} \left[\frac{50.22 - I}{71} \right]$$

or

$$I = 50.22 - 71 \sin \left(\frac{\pi}{4} - \theta_R \right)$$

Specifications

Wavelength Range	200–1600 nm
Aperture	12 mm
Wavefront Distortion	<1/8 wave
Retardance	0– 5.8π @ 300 nm 0– π @ 1600 nm
Resolution	0.001 wave @ null 0.01 wave @ 2π

References

1. Berek, M., *Zbl. Miner. Geol. Paläont.* 388, 427, 464, 580 (1913) (quoted in Born, M. and Wolf, E., *Principles of Optics*, 6th edition, Pergamon Press, London, 1980, p.694.)
2. Dodge, M., *Appl. Opt.* 23,12 1980-85 (1984)