

INTRODUCTION

When using GPIB to perform automated tests or experiments the user may want to know when specific events occur. This can be done by continually polling an instrument using software and checking to see if the conditional event occurred. This method ties up the GPIB bus and is difficult to detect multiple events. A better method for detecting specific events is to use Status Event Registers which will trigger Service Requests when an event occurs. This method does not require continual polling of the instrument and can handle multiple events. This method is not only ideal, but preferred since it will reduce the time required to create event checking software. This technical note examines how to use Status Event Registers and discusses an example to demonstrate the Service Request capabilities using an ILX LDC-3724B.

BACKGROUND

It is important to understand specifically how events and Status Event Registers are handled in the equipment of interest and how to set bits or “flags” in registers.

A register is comprised of bits, each represented by a 0 or a 1. The register is put together so that it represents an integer. An 8 bit register can be seen in Figure 1, where the numbers represent the index of the bit. The 0th index can occur on the right or on the left, and should be noted in the event register configuration.

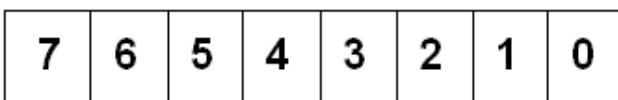

Figure 1: 8 Bit Register

To determine what integer is represented by the register, multiply the bits of the register (0 or 1) with 2^n , where n represents the bit's index. An example of this would be a register with values seen in Figure 2.

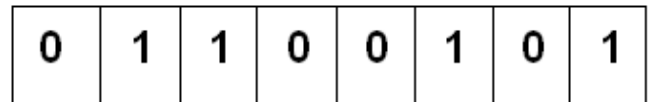

Figure 2: Register Example

In Figure 2, the right most bit represents the 0th index, referred to as the least significant bit (LSB). Starting from the LSB, we multiply and add up the bit representations as follows:

$$\text{value} = 1*2^0 + 0*2^1 + 1*2^2 + 0*2^3 + 0*2^4 + 1*2^5 + 1*2^6 + 0*2^7$$

which equals: $1 + 0 + 4 + 0 + 0 + 32 + 64 + 0 = 101$

In ILX Lightwave instrumentation there are two levels of registers which handle events. The top level is the 8 bit Service Request Enable register and Status Byte registers. The Service Request Enable register can be set by the user and used to specify which events will trigger service requests from the instrument. The Status Byte register is ANDed in a bitwise fashion with the Service request register, and the ANDed value is used to determine if a service request should be generated. The Status Byte register represents a summary of events which are represented in lower level Status Event registers. An example of the Status Byte and Service Request Enable registers can be seen in Figure 3.

TECH NOTE

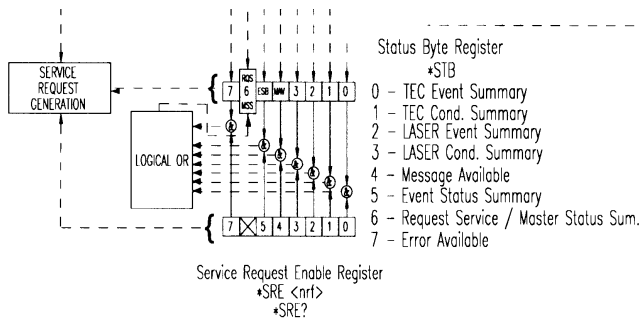

Figure 3: Status Byte and Service Request Enable Registers

The lower level Status Event registers have multiple bits (8 to 16 bits depending on the instrument) and each bit represents a specific event that can occur, such as an Open Circuit event or Output On/Off change events. An example of the event registers can be seen in Figure 4. The registers shown are the Laser Event Status and the Laser Event Status Enable registers in the LDC-3700B.

will signal an event flag in the Status Byte register, generating a service request by the instrument.

EXAMPLE

In this example, an LDC-3724B is used to control a laser diode in constant power and constant temperature modes. The laser diode being tested has been known to fail within the first 5 hours of operation. Because of this failure, the user is interested in the specific time that the laser diode fails, which can be detected by a Laser Current Limit error. The user is also interested in Voltage Limit errors, output on/off changes, and if a TEC Sensor Open error occurs.

Instead of continuously requesting the information from the LDC-3700B and tying up the GPIB bus, the user will be utilizing the Status Event Registers. In order to configure the registers, specific flag bits will be set to enable service request generations.

The four events that the user is interested in are:

- 1) TEC Sensor Open
- 2) Laser Current Limit
- 3) Laser Voltage Limit
- 4) Output On/Off Changes

The following registers and commands are used to set up the event registers so that the user will be notified when any of the above mentioned events occur. The status reporting scheme can be seen in Figure 5.

- The ESE register (Event Status Enable Register) is used to enable the generation of service requests. The bit that needs to be set is Bit 0, the Operation Complete flag.

COMMAND: *ESE 1

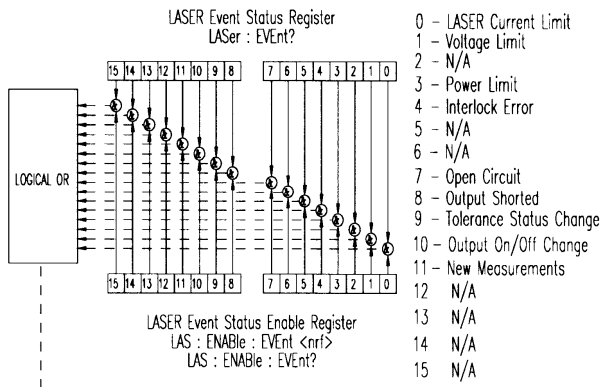

Figure 4: Laser Event Status Registers

The Laser Event Status Enable register can be set by the user. It is used to determine which events

TECH NOTE

- The Laser Event register will need to have 3 bits set: Bit 0 (LASER Current Limit), bit 1 (Voltage Limit), and Bit 10 (Output On/Off Change).

COMMAND: LAS:ENABLE:EVENT 1027

- The TEC Event register will only need to have 1 bit set: Bit 6.

COMMAND: TEC:ENABLE:EVENT 64

- The final register that needs to be set is the Service Enable Request register, which specifies which summary events will trigger a service request. This register has 2 bits set: bit 0 (TEC Event Summary), and bit 3 (Laser Event Summary).

COMMAND: *SRE 9

After sending the commands listed above, a service request will be generated by the instrument whenever the specified events occur. This service request pulls the GPIB RQS line high. An interrupt handling software routine can then be used to take appropriate action depending on the event that occurred.

CONCLUSION

By utilizing GPIB's capability of service request signaling, the user does not need to write specific event query and wait software. By using service requests, the GPIB bus is freed from continual poll and query commands which can make remote operation inefficient.

