

# Visible & IR Femtowatt Photoreceivers

*Models 2151 & 2153*



---

*These photoreceivers are sensitive to electrostatic discharges and could be permanently damaged if subjected to any discharges. Ground yourself adequately prior to handling these detectors or making connections. A ground strap provides the most effective grounding and minimizes the likelihood of electrostatic damage.*

---

## Warranty

Newport Corporation guarantees its products to be free of defects for one year from the date of shipment. This is in lieu of all other guarantees, expressed or implied, and does not cover incidental or consequential loss.

Information in this document is subject to change without notice.

Copyright 2001-1998, 2013, Newport Corporation. All rights reserved.

The New Focus logo and symbol are registered trademarks of Newport Corporation.

Document Number 90099907 Rev. F

# Contents

<b>Operation</b>	<b>5</b>
Introduction .....	5
Quick Start .....	6
Using the Photoreceivers .....	7
<b>Frequency Response and Noise</b>	<b>11</b>
Measuring Bandwidth.....	11
Measuring Noise.....	11
Using the 215X with a Chopper.....	14
Typical Frequency Response and Noise Spectra .....	15
<b>Using Filters and Optical Fiber</b>	<b>19</b>
<b>Characteristics</b>	<b>21</b>
Physical Specifications .....	21
Model 2151 Visible Femtowatt Photoreceiver .....	22
Model 2153 IR Femtowatt Photoreceiver .....	23
Responsivity .....	24
<b>Customer Service</b>	<b>25</b>
Technical Support .....	25
Service .....	25

This page has been intentionally left blank

# Operation

---

## Introduction

The Newport Models 2151 and 2153 are battery-powered photoreceivers with an extremely high-gain amplifier, making them ideal for low-light-level detection applications, such as spectroscopy and fluorescence measurements. They can detect optical signals in the sub-picowatt to 0.5 nanowatt range, and when used with a chopper and lock-in amplifier to reduce the measurement bandwidth, these photoreceivers can achieve sensitivity levels in the femtowatt range.

The Model 2151 has a 1-mm-diameter silicon PIN photodetector and can detect light from 300 to 1050 nm. The Model 2153 has a 1-mm-diameter InGaAs PIN photodetector and operates from 800 to 1700 nm. Typical responsivity curves for the units can be found in the “Responsivity” section on page 24.

The circuitry inside the Model 215X consists of a photodetector followed by an electronic gain stage. The incredibly high gain and low-noise performance of these photoreceivers was achieved by careful selection and design of the amplifier-resistor pair. A large feedback resistor is used to achieve the high transimpedance gain values while an ultra-quiet amplifier keeps noise to a minimum. A simplified schematic of the Model 215X circuitry is shown in Figure 1.

**Figure 1:**  
Functional  
schematic of  
the Model 215X  
circuitry

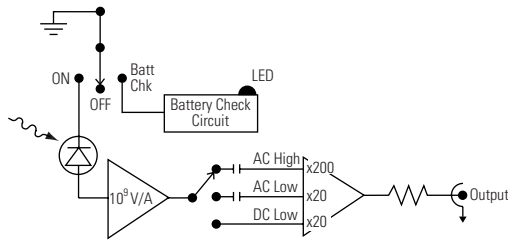

The femtowatt photoreceiver has three gain/bandwidth settings: DC Low, AC Low, and AC High. The Low gain setting has  $2 \times 10^{10}$  V/A transimpedance gain, and the High gain setting has  $2 \times 10^{11}$  V/A gain. The bandwidth of the DC setting is DC to 750 Hz, and the two AC settings have a 30 to 750 Hz bandwidth. For the AC settings the low-frequency roll-off at 30 Hz helps to reduce DC offsets and drift. The label on the front of the case summarizes the various gain and bandwidth values for the three settings.

The Model 215X runs off a single 9-volt alkaline battery and does not require a high-voltage power supply or a cooling system. So, in some applications the Model 215X can be used as a simple substitute for a photomultiplier tube. The BNC connector and the switches are conveniently located on the top of the photoreceiver for easy access and to minimize the thickness of the housing so it can fit in tight spaces.

**Note:**

*Diagrams and specifications for the Model 215X femtowatt photoreceiver can be found in the “Characteristics” chapter beginning on page 21.*

## Quick Start

- 1. Check the battery voltage.** The Model 215X is powered by a single 9-volt alkaline battery. To check the battery condition, push the red power switch to the **BATT CHK** position. If the green LED lights up, the battery is in good condition; if the

LED does not light, the battery needs to be replaced (see page 8).

2. **Mount the photoreceiver.** Use the 8-32 thread (M4 for metric versions) on the bottom of the casing to mount the photoreceiver to a post or pedestal.



*The threading is seated in a non-conductive plastic pad to reduce the electrical noise associated with ground loops. Be careful not to over-tighten when attaching the casing to a post or pedestal, or the threaded insert can strip out of the plastic pad.*

3. **Turn the power switch to “on.”** The output voltage should appear at the BNC connector.
4. **Adjust the gain.** Use the black switch on top of the receiver to set the gain DC Low, AC Low, and AC High. The bandwidths vary with the gain setting (the label on the front of the photoreceiver indicates the gain and bandwidth values).
5. **Turn the receiver off.** When you are finished with the receiver, return the power switch to the “off” position.

---

## Using the Photoreceivers

### Checking the Battery

The Model 215X is powered by a single, standard 9-volt alkaline battery. Under normal operating conditions with low light levels and a high impedance load attached to the BNC connector, the photoreceiver draws about 2.5 mA from the battery, and the battery lifetime is approximately 200 hours.

To check the condition of the battery, push the red power switch to the **BATT CHK** position. If the green LED lights up, the battery is in good condition.

When the battery voltage falls below about 6.5 volts, the green LED will not light up, and the battery should be replaced.

## Replacing the Battery

1. Turn the red power switch to “off” to prevent damage to the receiver.
2. Remove the screw on the back of the photoreceiver casing and remove the back cover.
3. Unplug the old battery by rotating it away from the circuit board about the snap-on terminal contacts
4. Install a new 9-volt alkaline battery.
5. Reinstall the back cover and screw.
6. Test the new battery’s status by pushing the power switch to the BATT CHK position.

## Detecting Light

### Optical Power and Output Voltage

The typical operating range for these receivers is from femtowatts up to 0.22 to 0.5 nanowatts, where the amplifier will saturate. Be careful to keep the optical power under the maximum optical power of 10 mW to avoid damaging the photodetector.

To compute the approximate output voltage for a given input optical power use the relationship

$$V_{out} = P_{in} \cdot R \cdot G$$

where  $P_{in}$  is the input optical power in watts,  $R$  is the photodetector’s responsivity in A/W (see page 24 for typical responsivities), and  $G$  is the amplifier’s transimpedance gain in V/A.

For example, the Model 2151 on the DC Low gain setting and with 0.1 nW of optical power at 900 nm



will have an output voltage of approximately  $(0.1 \text{ nW}) \cdot (0.5 \text{ A/W}) \cdot (2 \times 10^{10} \text{ V/A}) = 1 \text{ V}$ .

The maximum optical power that can be detected by the photoreceiver is determined by the input optical power at which the transimpedance gain stage saturates. We can calculate the saturation power at 900 nm for the Model 2151 assuming a maximum output voltage of 5 volts. (The output can typically generate greater than 5 volts, but to be conservative we assume a maximum output of 5 volts.)

Using the expression  $5 \text{ V} = P_{\text{sat}} \cdot R \cdot G$ , the Model 2151 has a saturation power of 0.5 nW for the DC Low and AC Low gain settings and 0.05 nW for the AC High gain setting. At other wavelengths where the responsivity is lower, the saturation power increases inversely with responsivity.

## Shielding the Photodetector

Since the femtowatt photoreceivers have extremely high sensitivity, you should to be careful to shield the photodetector from any unwanted light sources. The simplest technique is to use baffling or other physical barriers such as black cloth or opaque beam tubes to block stray light. Use of the Model 1280 1" filter holder (see page 19) with appropriate optical bandpass filters is also highly recommended.

To illustrate the problems that can be caused by even a low power point source far from the photoreceiver, take a look at the following calculation:

$$P_{\text{received}} = P_o \frac{\pi r^2}{4\pi R^2} = \frac{1}{4} P_o \left(\frac{r}{R}\right)^2 = 0.25 \cdot 1 \text{ mW} \cdot \left(\frac{0.5 \text{ mm}}{1 \text{ m}}\right)^2 = 0.06 \text{ nW}$$

where  $r$  is the photodiode radius,  $R$  is the distance from a point source to the photodiode,  $P_o$  is the power emitted from a point source, and  $P_{\text{received}}$  is the power which will be incident on the photodiode from that point source at that distance.

Notice that with a responsivity of 0.5 A/W and transimpedance gain of  $2 \times 10^{10}$  V/A, a 1-mW point source (such as a bright LED) at a distance of 1 meter gives an output voltage of 0.6 V. This illustrates that you cannot be too careful to exclude extraneous optical signals when you want to measure power at femtowatt levels.

Since stray light typically has its strongest frequency components at DC and line frequency harmonics, optical chopping and synchronous detection techniques are quite valuable for improving your measurement sensitivity.

## **AC versus DC Settings**

The internal circuitry of the femtowatt photoreceiver consists of a two-stage amplifier (see Figure 1). The first stage is a transimpedance amplifier with a fixed gain of  $10^9$  V/A. The second stage is a variable-gain voltage amplifier with the following three settings:

1. Gain of 20, DC-coupled amplifier
2. Gain of 20, AC-coupled amplifier
3. Gain of 200, AC-coupled amplifier

The AC-coupled amplifier uses a passive RC high-pass filter with a corner frequency of 30 Hz. This stage may still result in some small DC-level output, depending on the DC offset of the amplifier.

Keeping this two-stage circuit in mind, you will not be confused by saturation of the first stage amplifier. If your DC light level is sufficient to saturate the first stage amplifier, AC signals will be reduced, distorted, or removed entirely by the saturation effects. Switching to an AC output under these conditions will not recover the AC signal which is lost in the first stage. The recourse under these conditions is to reduce the optical power level.

# Frequency Response and Noise

---

## Measuring Bandwidth

The frequency response and noise characteristics of the femtowatt photoreceiver depend on the selected gain. Figures 2 and 3 on the following pages give the typical frequency response and noise behavior for the photoreceivers at each of the three gain settings—DC Low, AC Low, and AC High. The frequency response of the transimpedance gain is plotted using the expression

$$20 \cdot \log \left[ \frac{\text{Gain}(f)}{\text{Gain}(0)} \right]$$

where  $f$  is the frequency and  $\text{Gain}(0)$  is the gain at DC. The photoreceiver's bandwidth is defined as the frequency where the gain has decreased by 3 dB, or a factor of  $\sqrt{2}$ .

---

## Measuring Noise

The photoreceiver noise is characterized using the noise equivalent power (NEP), which is a measure of the weakest optical signal that the photoreceiver can detect. The NEP is the optical power which will produce a signal-to-noise ratio of 1 in a 1-Hz bandwidth. The minimum detectable optical power can be found using the relationship

$$\text{Minimum Optical Power} = \text{NEP} \cdot \sqrt{BW},$$

where  $BW$  is the bandwidth. Note that NEP is a wavelength-dependent quantity that changes with the photodetector's responsivity.

Another way to characterize the noise is with the photocurrent noise ( $I_n$ ), which is related to NEP by

$$I_n = R \cdot NEP$$

where  $R$  is the photodetector's responsivity. The photocurrent noise is independent of wavelength because it gives the photoreceiver's noise with the photodetector's responsivity factored out.

To characterize the noise of the femtowatt photoreceivers, the output electrical noise spectrum is measured with a spectrum analyzer. This voltage noise spectrum is converted to an equivalent optical photocurrent noise by dividing the voltage noise by the transimpedance gain ( $V/A$ ). The photocurrent noise,  $I_n(f)$ , has units of  $fA/\sqrt{Hz}$  and is plotted in Figures 2 and 3 using the expression  $20 \cdot \log[I_n(f)/1 A]$ .

## Calculating NEP

The noise equivalent power (NEP) can be calculated by dividing the photocurrent noise by  $R$ , the detector's responsivity (see Figure 6 on page 24).

For instance, the Model 2151 on the DC Low gain setting has a minimum photocurrent noise of  $6 fA/\sqrt{Hz}$  (see Figure 2c). When operating around 900 nm where the responsivity is about  $0.5 A/W$ , the NEP is  $12 fW/\sqrt{Hz}$ .

The integrated noise equivalent power from DC to 750 Hz is then obtained by multiplying the average NEP by  $\sqrt{BW}$ , the square root of the bandwidth. The expression  $BW = 2\pi f_{3-dB}/4$  for a one-pole low-pass filter is useful for calculating the equivalent noise bandwidth. For the Model 215X with a 3-dB bandwidth of 750 Hz, the equivalent noise bandwidth is  $BW = 1200$  Hz.

This gives an optical noise equivalent power of about 0.4 pW, which means that the minimum detectable optical signal (with a signal-to-noise ratio of 1 and the

full 750 Hz bandwidth) for the Model 2151 on the DC Low setting with 900 nm light is 0.4 pW. “Using the 215X with a Chopper” on page 14 discusses using an optical chopper and a lock-in amplifier to reduce the minimum detectable power to much lower levels.

## Calculating Output-Voltage Noise

The output-voltage noise can be calculated from

$$G \cdot R \cdot NEP \cdot \sqrt{BW}$$

where  $G$  is the transimpedance gain (V/A),  $R$  is the photodiode responsivity (A/W),  $NEP$  is the average noise equivalent power, and  $BW$  is the bandwidth. This gives an output noise voltage for the Model 2151 on the DC Low setting of  $(2 \times 10^{10} \text{ V/A}) \cdot (0.5 \text{ A/W}) \cdot (12 \text{ fW}/\sqrt{\text{Hz}}) \cdot (1200 \text{ Hz})^{1/2} = 4 \text{ mV}_{\text{rms}}$ .

Something to consider when determining the noise limits is that there can be other environmental sources of noise in a measurement. The most likely noise source you will encounter when using the femtowatt photoreceiver is unwanted optical signals. It will be extremely helpful to use optical filters and a layout which prevents stray light from reaching the photoreceiver.

## Summary

To summarize, the NEP is  $12 \text{ fW}/\sqrt{\text{Hz}}$  for the Model 2151 on the DC Low setting, and this yields an output noise voltage of  $4 \text{ mV}_{\text{rms}}$ . Viewed another way, for operation at the peak responsivity wavelength of 900 nm and for the DC Low gain setting, you will achieve a signal-to-noise ratio of unity if the input power is 0.4 pW. Note that this assumes operation without any post-photoreceiver filtering and with the full photoreceiver bandwidth of 750 Hz. By using an electronic band-pass filter or an optical chopper and lock-in detection, the minimum detectable optical signal can be reduced significantly.

---

## Using the 215X with a Chopper

Because the photocurrent in the femtowatt photoreceiver is generated in a photodiode, and the gain is set by fixed resistors, the output voltage under steady illumination is quite stable. Therefore, for many applications, you may read the photoreceiver's output directly. This gives you a measurement bandwidth of 750 Hz, or a time resolution of about 1 msec. You can easily reduce this bandwidth by low-pass filtering or averaging the output voltage to get improved noise performance.

When noise reduction beyond what low-pass filtering can provide is needed, you must find a way to limit the measurement bandwidth. One common technique is to use an optical chopper and synchronous detection. The chopper technique will be particularly useful because an interfering optical noise source can be differentiated from the desired optical signal by passing the desired optical beam through a chopper.

The chopper should be run at a frequency lower than the 750-Hz bandwidth of the femtowatt photoreceiver. Because many interfering optical signals and residual noise in amplifier electronics occur at harmonics of the line-power frequency, your chopper should be set to avoid these frequencies. For instance, the chopper can be run at 470 Hz, using a synchronous detection with a two-pole lock-in amplifier time constant of 1 second. Now the collected data is limited to a bandwidth of 0.125 Hz, and the photoreceiver noise contribution is reduced to an integrated noise equivalent power of 4.2 fW at peak responsivity (visible), or 7.8 fW for the Model 2153 infrared photoreceiver. Excess optical noise contributions with frequency components outside of the 0.125-Hz window around 470 Hz are rejected.

# Typical Frequency Response and Noise Spectra

The 3-dB frequency bandwidth is defined as the frequency where the Model 2151's transimpedance gain has decreased by a factor of  $\sqrt{2}$ . For the Model 2151 on the DC Low setting the gain is  $2 \times 10^{10}$  V/A, and the bandwidth is DC–750 Hz. The AC Low setting has the same gain, and the bandwidth is 30–750 Hz. The gain on the AC High setting is  $2 \times 10^{11}$  V/A, and the bandwidth is 30–750 Hz. The noise spectrum is plotted in units of photocurrent noise,  $fA/\sqrt{Hz}$ .

**Figure 2:**  
Typical  
frequency  
response and  
noise spectra  
for the Model  
2151 with the  
gain set to  
(a) DC Low,  
(b) AC Low, and  
(c) AC High.

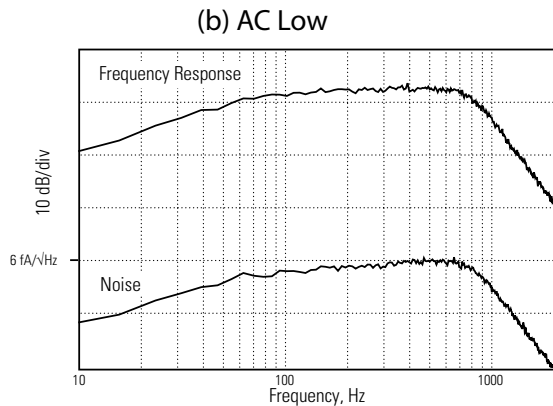
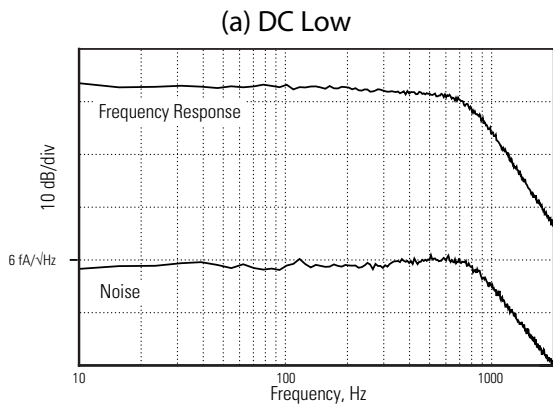

(c) AC High

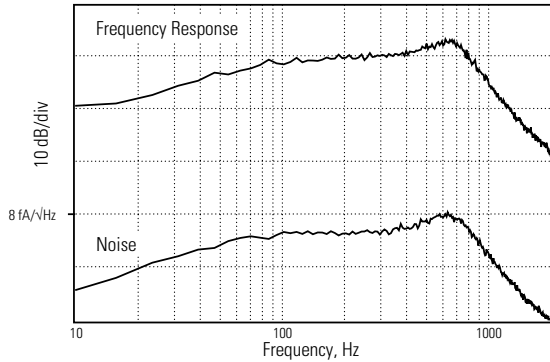

For the Model 2153 on the DC Low setting the gain is  $2 \times 10^{10}$  V/A, and the bandwidth is DC–750 Hz. The AC Low setting has the same gain, and the bandwidth is 30–750 Hz. The AC High setting has a  $2 \times 10^{11}$  V/A gain, and the bandwidth is 30–750 Hz. The noise spectrum is plotted in units of photocurrent noise,  $fA/\sqrt{Hz}$ .

**Figure 3:**

Typical frequency response and noise spectra for the Model 2153 with the gain set to (a) DC Low, (b) AC Low, and (c) AC High.

(a) DC Low

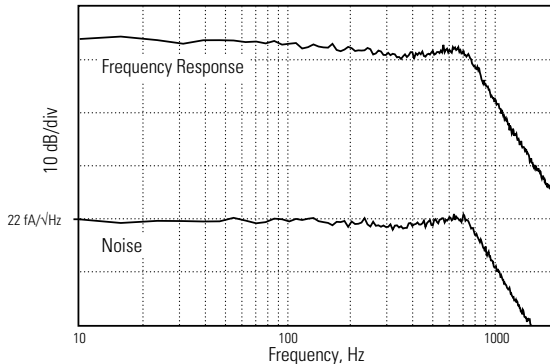



(b) AC Low

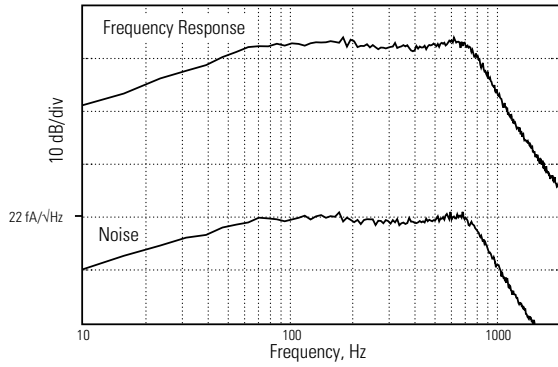

(c) AC High

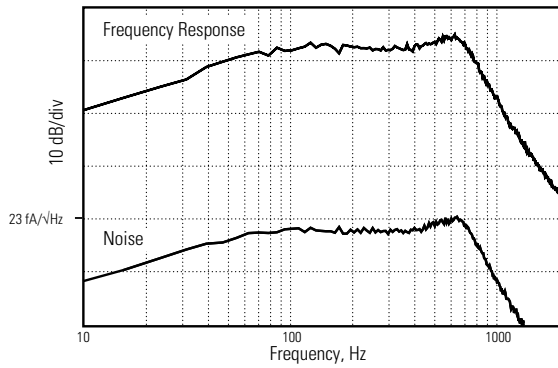

This page has been intentionally left blank

# Using Filters and Optical Fiber

Newport offers accessories that can be used for attaching a 1"-diameter filter or an optical fiber to the Model 215X femtowatt photoreceiver. These accessories are sold separately, and they are not supplied with the photoreceiver. Both accessories attach to the unit using the 1.04-32 threads located in the casing around the photodetector. Note that the accessories are also compatible with the Model 162X nanosecond photodetector.

The Model 1280 1" filter holder (see Figure 4) allows a 1"-diameter optic to be mounted in front of the photo-detector. For instance, you can mount a colored glass filter to remove unwanted wavelengths or attach a neutral-density filter to attenuate the optical-power incident on the photodetector. Since the Model 215X has extremely high gain, using an optical bandpass filter to remove background optical noise sources can help improve your measurement sensitivity. The Model 1280 has a plastic ring for mounting a filter that is up to about 0.25" (6.4-mm) thick, or a thicker optic can be held in place using the 6-32 nylon-tipped set screw. Use a 1/16" or 1.5-mm Allen key or ball-driver to adjust the set screw.

The Model 1281 FC fiber adapter (see Figure 4) allows a FC-connectorized fiber to be attached in front of the photodetector. If you need fibers and accessories for coupling light into optical fibers, a variety of fiber couplers, fiber collimators and pigtailed are available from Newport.

**Figure 4:**  
Model 1280  
filter holder  
and Model  
1281 FC-fiber  
adapter

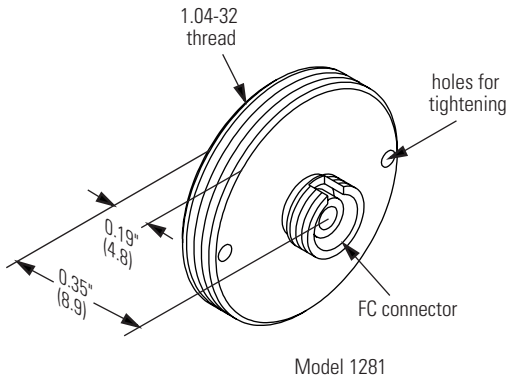
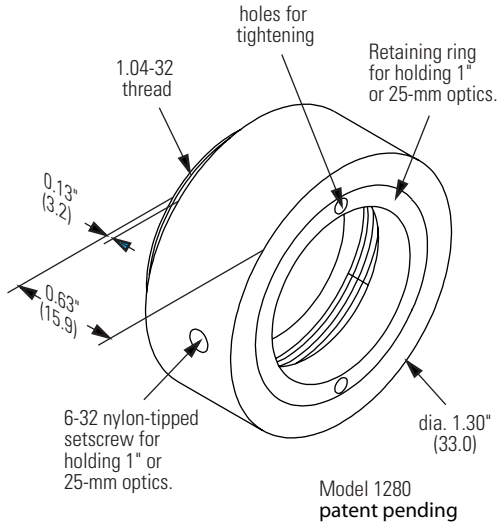

# Characteristics

## Physical Specifications

**Figure 5:**

Mechanical drawing of the Model 215X casing

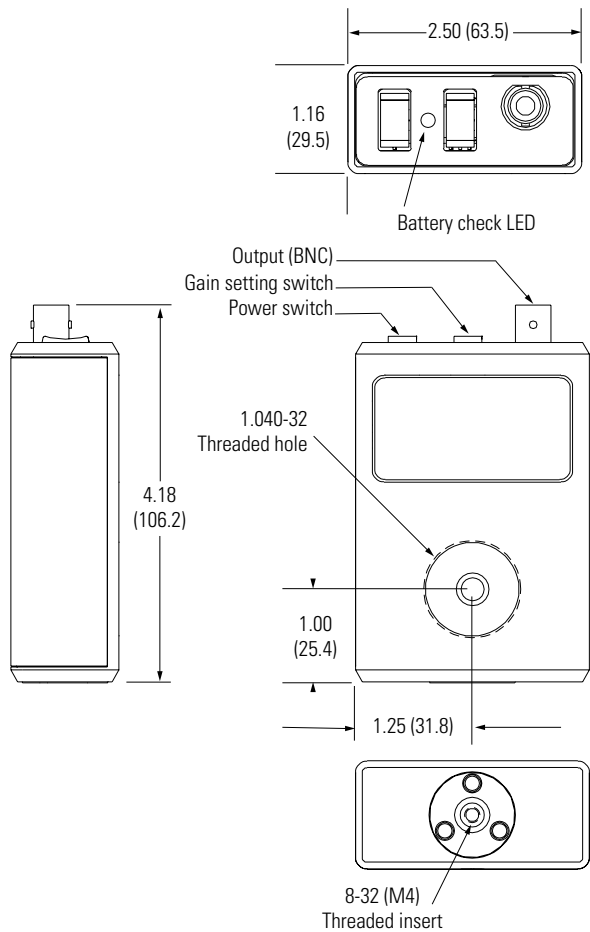

## Model 2151 Visible Femtowatt Photoreceiver

	Model 2151		
Wavelength Range	300–1050 nm		
Detector Material/Type	Silicon/PIN		
Detector Diameter	1.0 mm		
Typical Max. Responsivity	0.5 A/W (at 900 nm)		
Maximum Optical Power	10 mW		
Gain Setting	<b>DC Low</b>	<b>AC Low</b>	<b>AC High</b>
Transimpedance Gain (V/A)	$2 \times 10^{10}$	$2 \times 10^{10}$	$2 \times 10^{11}$
3-dB Bandwidth (Hz)	DC–750	30–750	30–750
Max. Conversion Gain (V/W)	$1 \times 10^{10}$	$1 \times 10^{10}$	$1 \times 10^{11}$
cw Saturation Power (at 900 nm)	0.5 nW	0.5 nW	0.05 nW
Minimum NEP	$\leq 16 \text{ fW} / \sqrt{\text{Hz}}$		
Output Impedance	100 $\Omega$		
Electrical Output Connector	BNC		
Power Requirements	One 9-V alkaline battery		
Battery Lifetime	Approx. 200 hours		

## Model 2153 IR Femtowatt Photoreceiver

	Model 2153		
Wavelength Range	800–1700 nm		
Detector Material/Type	InGaAs/PIN		
Detector Diameter	1.0 mm		
Typical Max. Responsivity	1.0 A/W (at 1600 nm)		
Maximum Optical Power	10 mW		
Gain Setting	<b>DC Low</b>	<b>AC Low</b>	<b>AC High</b>
Transimpedance Gain (V/A)	$2 \times 10^{10}$	$2 \times 10^{10}$	$2 \times 10^{11}$
3-dB Bandwidth (Hz)	DC–750	30–750	30–750
Max. Conversion Gain (V/W)	$2 \times 10^{10}$	$2 \times 10^{10}$	$2 \times 10^{11}$
cw Saturation Power (at 1600 nm)	0.25 nW	0.25 nW	0.025 nW
Minimum NEP	$\leq 23 \text{ fW}/\sqrt{\text{Hz}}$		
Output Impedance	100 $\Omega$		
Electrical Output Connector	BNC		
Power Requirements	One 9-V alkaline battery		
Battery Lifetime	Approx. 200 hours		

# Responsivity

**Figure 6:**  
Typical  
responsivity of  
the silicon PIN  
photodetector  
(Model 2151)  
and the InGaAs  
PIN photo-  
detector  
(Model 2153)

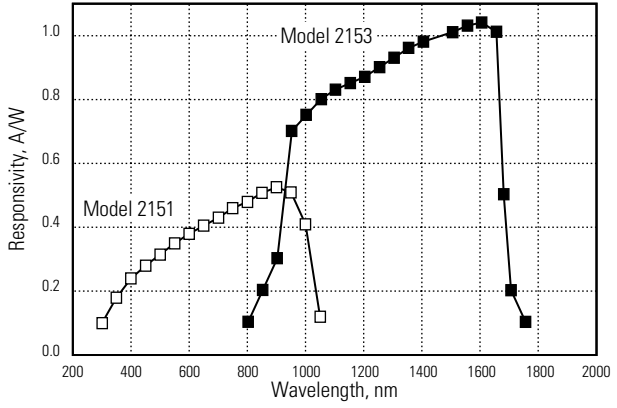



# Customer Service

---

## Technical Support

Information and advice about the operation of any Newport product is available from our applications engineers. For quickest response, ask for “Technical Support” and know the model number and serial number for your product.

**Hours:** 8:00–5:00 PST, Monday through Friday (excluding holidays).

**Phone:** 1-877-835-9620

Support is also available by email and chat

**Chat:** Connect with us at [www.newport.com](http://www.newport.com)

**Email:** [tech@newport.com](mailto:tech@newport.com)

We typically respond to emails within one business day.

---

## Service

In the event that your device malfunctions or becomes damaged, please contact Newport for a return merchant authorization (RMA) number and instructions on shipping the unit back for evaluation and repair.