

MEMS MS1X2 Optical Switch

Operation Manual

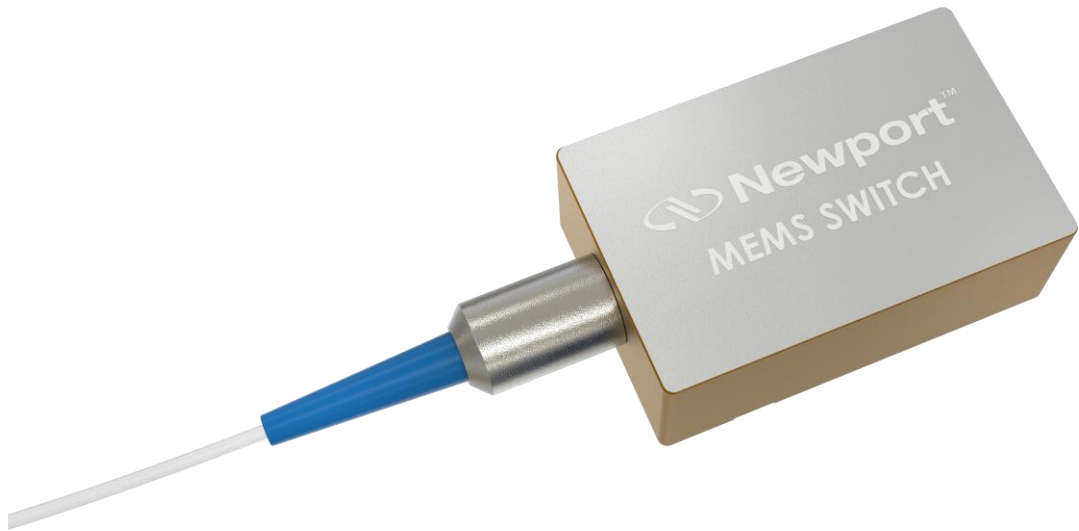



This Product is ESD sensitive

**Please take all necessary precautions
when handling the MEMS switch**

Contents

1. PRODUCT OVERVIEW	4
1.1 MEMS 1x2 Optical Switch	4
2. SWITCH OPERATION	5
2.1 Pin Assignments	5
2.2 Electrical Specifications	6
2.3 Environmental Specification	6
3. MECHANICAL DIMENSIONS	7
4. TTL INTERFACE	8
4.1 Parallel Digital I/O Control	8
4.2 Parallel Digital I/O Timing	8
5. HANDLING FIBEROPTIC COMPONENTS AND CABLES	9
5.1 Handling Fiber Optic Cables	9
5.2 Storing Optical Connectors	10
5.3 Cleaning Optical Connectors	10
5.4 Mating Optical Connectors	10

Tables

Table 1. TTL Interface Pin Assignment.....	5
Table 2. Electrical Specifications	6
Table 3. Environmental Specifications	6
Table 4. MEMS 1x2 Logic Table for TTL Interface	8
Table 5. Parallel Digital I/O Timing Parameters.....	9

Figures

Figure 1. MEMS 1x2 Switch Operation Schematic.....	4
Figure 2. Pin Assignment Schematic.....	5
Figure 3. Parallel Digital I/O Timing Diagram	8
Figure 4. Fiber optic component, connectors, and fiber pigtailed.....	10

1. Product Overview

This manual is intended for use with the following part numbers:

MS-1315TT-12
MS-1315TT-12-PC
MS-1315TT-12-APC

1.1 MEMS 1x2 Optical Switch

Newport's MEMS 1x2 Switch is based on a micro-electro-mechanical system (MEMS) chip. The MEMS chip consists of an electrically movable mirror with two axes of rotation. Voltages applied to the MEMS chip cause the mirror to tilt along one or both axes, which changes the coupling of light between a common fiber and N input/output fibers.

The MEMS 1x2 Switch is a non-latching device. When electrical power is removed, the position of the switch will automatically move to its default position. The default position of a standard MEMS 1x2 Switch is to block the light moving through the switch. Upon request the default position can be set to one of the 2 fibers.

An operation schematic for the MEMS 1x2 Switch is presented in Figure 1.



Figure 1. MEMS 1x2 Switch Operation Schematic

Note: The above schematic shows the MEMS switch operating in a 1 to 2 application. The common fiber is used as the input, and the 2 channels are used as output fibers. The switch is bidirectional, however, and can be used as either a 1x2 or as an 2x1 switch.

When the switch is operated as an 2 to 1, the 2 channels are the 2 inputs and the common fiber is the output.

2. Switch Operation

2.1 Pin Assignments

The MEMS 1x2 Switch operates through a 14-pin interface. Pin assignments are listed in the following table. The relative position of each pin is presented in Figure 2.

The 1xN built-in driver is based on an 8051 Microcontroller with external 16-bit D/A converter (DAC) and amplifier. This driver will support parallel digital data input with STROBE control.

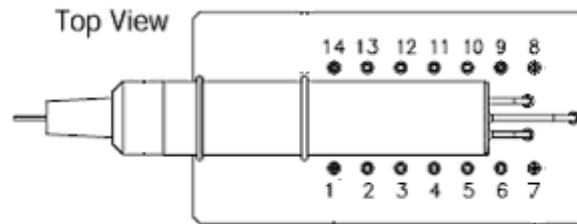

Figure 2. Pin Assignment Schematic

Table 1. TTL Interface Pin Assignment

Pin	Name	Description	Direction	Note
1	NC	No Connection		
2	VCC	Power Supply	IN	
3	/STROBE	Falling Edge Active	IN	
4	GND	Signal & Power Ground		
5	D0	Data 0 Input	IN	
6	D1	Data 1 Input	IN	1
7	D2	Data 2 Input	IN	2
8	NC	No Connection		
9	NC	No Connection		
10	NC	No Connection		
11	GND NC	Case Ground for MS1 Switches No Connection for MSP Switches		
12	NC	No Connection		
13	D3	Data 3 Input	IN	3
14	/RESET	Hardware Reset; Logic Low Active	IN	4

1. D1 should be connected to Ground for switches with $N \leq 2$. For switches with $N > 2$, D1 is an active data bit.
2. D2 should be connected to Ground for switches with $N \leq 4$. For switches with $N > 4$, D2 is an active data bit.
3. Pin 13 serves as the D3 data input. For 1xN switches with $N \leq 8$, D3 should be connected to Ground. For 1xN switches with $N > 8$, D3 is used as the data input.
4. Logic high for normal switch operation. Logic low performs hardware reset.

2.1.1 VCC (Pin 2)

VCC (pin 2) is the power supply pin to the MEMS 1x2 Switch. The value of the supply voltage can vary within the specified range without affecting the switch output. If VCC is absent, the switch will revert to the default position (parking state for standard products). The switch will initialize to the default state at start-up (i.e. at the time VCC receives voltage).

2.1.2 Reset (Pin 14)

Set the reset pin to logic high to allow for normal switch operation. When the reset pin is set to logic low the switch will reset, which will revert the switch to its default state and reset the internal MCU. The default state is defined when the switch is manufactured and if not otherwise specified it will be set to the parking state, which is optically off. Please refer to the "Reset" plot in the timing diagram of section 4.2 for clarification and timing requirements. Also, please be aware that for MEMS switches with firmware version 3.4 or earlier, this pin is not utilized and can be left floating.

2.2 Electrical Specifications

Table 2. Electrical Specifications

Parameter	Minimum	Maximum	Damage Threshold	Unit
Latching Type	Non-latching		-	
VCC voltage	4.75	13.2	15	VDC
VCC power consumption (at 12V)	-	170	-	mW
Digital I/O logic high	2.0	5.25	5.8	VDC
Digital I/O logic low	0	0.8	5.8	VDC

2.3 Environmental Specification

Table 3. Environmental Specifications

Parameter	Specification	Unit
Operating Temperature	-5 to 70	°C
Storage Temperature	-40 to 85	°C

3. Mechanical Dimensions

(Units: mm)

Bare Fiber

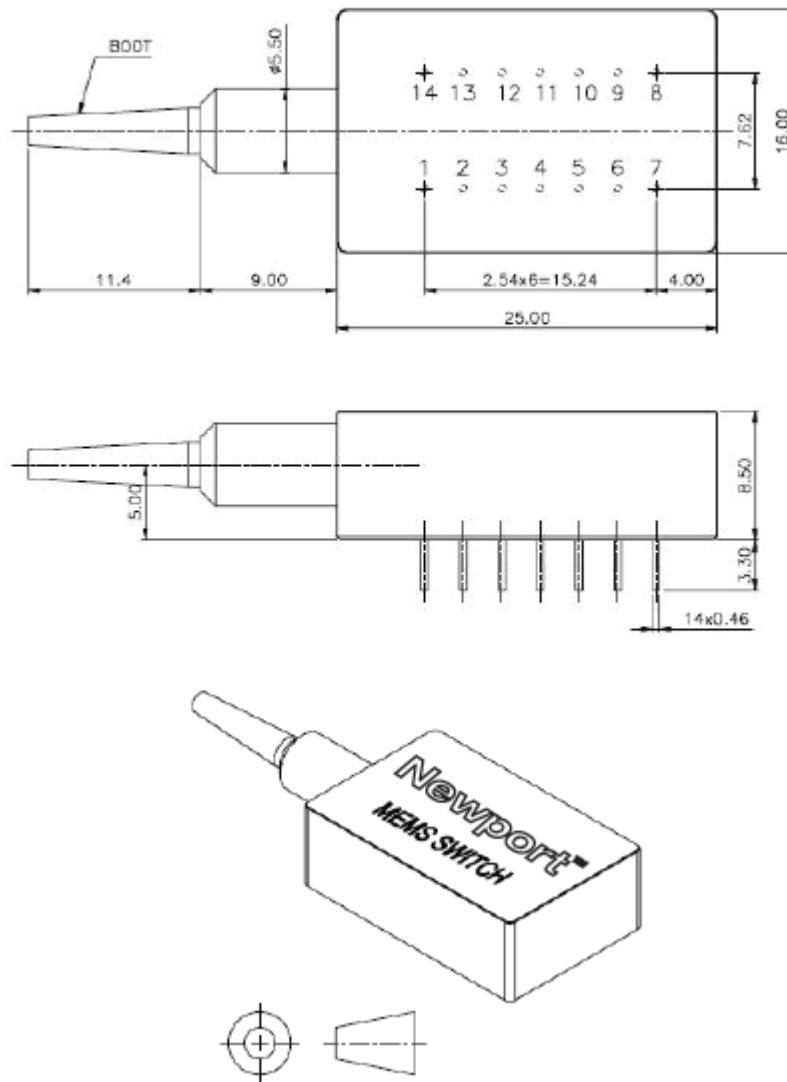

Figure 3. MS1 with Bare Fiber Mechanical Specifications

4. TTL Interface

4.1 Parallel Digital I/O Control

TTL control is only available for switches having up to 16 channels since there are four TTL control pins (D0, D1, D2, D3).

With TTL control, switches with <16 channels may be set to a parking state (<-50dB Crosstalk on all channels) by selecting the “N+1” channel. For example, with a 1x4 switch, the parking state is defined as channel 5 within Table 5 below. For switches with 16 channels, the parking state is not available with TTL control.

Table 4. MEMS 1x2 Logic Table for TTL Interface

Channel	D3	D2	D1	D0
Channel 1	0	0	0	0
Channel 2	0	0	0	1
Channel 3	0	0	1	0
Channel 4	0	0	1	1
Channel 5	0	1	0	0
Channel 6	0	1	0	1
Channel 7	0	1	1	0
Channel 8	0	1	1	1
Channel 9	1	0	0	0
Channel 10	1	0	0	1
Channel 11	1	0	1	0
Channel 12	1	0	1	1
Channel 13	1	1	0	0
Channel 14	1	1	0	1
Channel 15	1	1	1	0
Channel 16	1	1	1	1

4.2 Parallel Digital I/O Timing

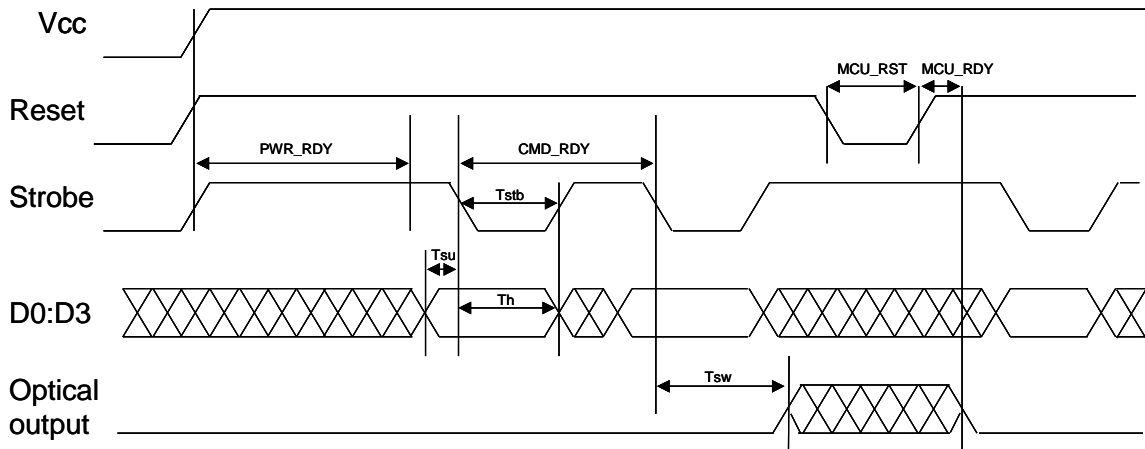

Figure 3. Parallel Digital I/O Timing Diagram

Table 5. Parallel Digital I/O Timing Parameters

Parameter	Description	Min	Max	Units
Tsu	Setup time. The channel address <D0:D3> and RESET inputs must remain stable preceding the falling edge of STROBE	1	-	µs
Th	Hold time. The channel address <D0:D3> and RESET inputs must remain stable following the falling edge of STROBE	10	-	µs
Tstb	STROBE pulse width	1		µs
Tsw	Switching time. During this period the switch would have no optical transmission on all channels.		1x2 – 10ms 1x4 / 1x8 – 20ms 1x12 – 30ms	ms
PWR_RDY	Power-up ready. No channel switching possible and STROBE/TTL control would not work during this startup time.	-	200	ms
MCU_RST	A falling pulse will revert the switch to the default state	-	100	µs
MCU_RDY	MCU reset ready begins from the rising edge of the reset pulse	-	10	ms
CMD_RDY	Command ready. The delay is required between two strobe signals	-	15	ms

5. Handling Fiberoptic Components and Cables

Fiber optic components require special handling. Follow these guidelines when handling the cables and connectors.

5.1 Handling Fiber Optic Cables

To avoid cable damage and to minimize optical loss, follow these guidelines when handling fiber optic cables.

- Handle the fiber pigtail outputs carefully.
- The minimum bend radius for most optical cables is 35mm. Never bend an optical cable more sharply than this specification. Optical performance will degrade, and the cable might break.
- Avoid bending the optical cable near a cable strain relief boot. Bending an optical cable near a strain relief boot is one of the easiest ways to permanently damage the optical fiber.

- Avoid bending the optical cable over a sharp edge.
- Avoid using cable tie wraps to hold optical cable. Tie wraps when tightened can create microbends or break an optical cable. Microbends can cause a dramatic reduction in optical performance.
- Do not pull on the bare fiber as this can break the fiber inside the component.
- Avoid using soldering irons near optical cables. Accidental damage can easily occur when a soldering iron is used near an optical cable. In addition, solder splatter can contaminate and permanently damage optical fiber connectors.
- To assure the most stable, repeatable optical performance after the optical cables have been connected, immobilize the cables using wide pieces of tape or another form of mechanical cushion.

5.2 Storing Optical Connectors

All switches that include optical connectors are shipped with dust caps covering those optical connectors. Optical connectors should always remain covered when the instrument is not in use.

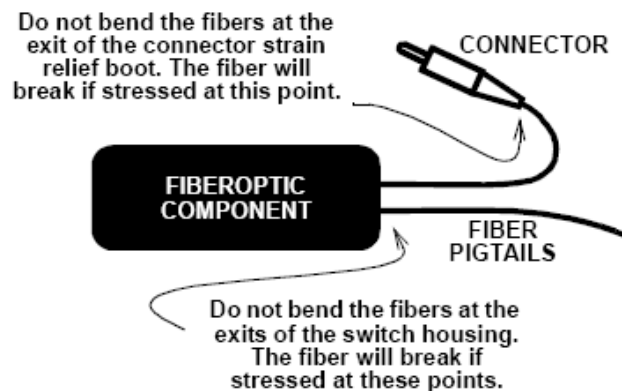

Figure 4. Fiber optic component, connectors, and fiber pigtails

5.3 Cleaning Optical Connectors

Clean any exposed connector using a cleaning kit supplied by the connector manufacturer or high-grade isopropyl alcohol and a cotton swab. To clean with alcohol and a swab, dab the tip of a cotton swab in alcohol and then shake off any excess alcohol. The tip should be moist, not dripping wet. Stroke the swab tip gently across the surface of the connector and around the connector ferrule. Either allow the connector a minute to dry or blow-dry the connector using compressed air. Be careful when using compressed air: improper use may deposit a spray residue on the connector.

5.4 Mating Optical Connectors

Follow these instructions when mating optical connectors.

- Clean both connectors prior to mating. Any small particles trapped during the mating process can permanently damage the connector.

- Smoothly insert the appropriate connector ferrule into the adapter. Do not allow the fiber tip to contact any surface. If the tip accidentally contacts a surface before mating, stop. Re-clean the connector and try again.
- Tighten the connector until it is finger tight or to the torque specified by the connector manufacturer. Do not over-tighten the connector as this can lead to optical loss and connector damage.
- Check the optical insertion loss. If the loss is unacceptable, remove the connector, re-clean both ends of the mate, and reconnect them. You may have to repeat this process several times before a low-loss connection is made.
- After you make the connection, monitor the stability of the optical throughput for a few minutes. Optical power trending (slowly increasing or decreasing) is caused by the slow evaporation of alcohol trapped in the connector. Continue to monitor optical power until it stabilizes. If the loss is unacceptable, re-clean the connectors and start again.