

Sol1A Solar Simulator

ORIEL[®] Sol1A[™] CLASS ABB SOLAR SIMULATOR



User's Manual



M940x1A Rev D

TABLE OF CONTENTS

1	INTRODUCTION	4
2	FEATURES AND SPECIFICATIONS	5
	2.1 Components Included	5
	2.2 Electrical Specifications	5
	2.3 Specifications and Certifications	6
3	SAFETY	9
	3.1 Electrical Hazards	9
	3.2 Ultraviolet Radiation Hazards.....	9
	3.3 Ozone	11
	3.4 Lamp Hazards	11
	3.5 Electromagnetic Interference (EMI)	12
4	SETTING UP THE SYSTEM	13
	4.1 Unpacking the System	13
	4.2 Mounting the System	15
	4.3 Installing Filters	16
	4.4 Lamp Access/ Removing Panels	18
	4.5 Installing the Lamp	19
	4.5.1 Installing the 150W Lamp	19
	4.5.2 Installing the 450W Lamp	20
	4.5.3 Installing the 1.0kW Lamp.....	21
	4.5.4 Installing the 1.6 kW Lamp	22
	4.6 Electrical Connections.....	23
	4.7 Illuminator Housing Controls	25
5	USING THE SYSTEM	26
	5.1 SETTING UP THE POWER SUPPLY.....	26
	5.2 Shutter Control	26
	5.3 Starting the Lamp	26
	5.4 Power Supply and DIGITAL EXPOSURE System.....	26
6	ROUTINE MAINTENANCE	27
	6.1 Lamp Replacement	27
	6.2 Lamp Alignment	32
	6.3 Cleaning Optics	34
7	TROUBLESHOOTING	35
8	WARRANTY AND RETURNS	37
	8.1 Contacting Oriel Instruments.....	37
	8.2 Request for Assistance / Service	38
	8.3 Repair Service.....	38
	8.4 Non-Warranty Repair	39
	8.5 Warranty Repair	39
	8.6 Loaner / Demo Material.....	40
9	PRODUCTS AND ACCESSORIES	41
10	APPENDIX A: Dimensional and Mounting Diagrams	42
11	APPENDIX B: Reports and Certifications	46
	11.1 Non Uniformity Report.....	46
	11.2 Temporal Instability Report	47
	11.3 Spectral Match Report	48

FIGURES

Figure 1: Performance Validation Certificate for ORIEL® Sol1A™	8
Figure 2: Proper installation of air mass filters for various models	16
Figure 3: Air Mass Definitions	17
Figure 4: Installing the 150W Lamp	19
Figure 5: Installing the 450W Lamp	20
Figure 6: Lamp Assembly for 1kW	21
Figure 7: Installing the 1.6kW Lamp	22
Figure 8: 2x2 System (94021A)	42
Figure 9: 4x4 System (94041A)	43
Figure 10: 6x6 System (94061A)	44
Figure 11: 8x8 System (94081A)	45

PHOTOS

Photo 1: Sol1A™ Solar Simulator and Power Supply	5
Photo 2: Lamp and heat sink (with packing crate)	13
Photo 3: Air mass filter assembly (stored in case)	14
Photo 4: Unpacked components	14
Photo 5: Simulator and power supply unpacked	14
Photo 6: Air Mass Filters: AM0 (2"x2"), AM1.5D filters (2"x2")	17
Photo 7: Removing the lamp access panel	18
Photo 8: Lamp access panel removed	18
Photo 9: 150W Lamp with adapter attached	19
Photo 10: 450W Lamp with heat sink attached	20
Photo 11: 1kW lamp with heat sink attached	21
Photo 12: 1.6 kW lamp with heat sink attached	22
Photo 13: Electrical connections on simulator (black and gray cables)	23
Photo 14: Electrical connections on power supply (black and gray cables)	23
Photo 15: The illuminator housing control panel	25
Photo 16: The Illuminator (rear view)	27
Photo 17: Removing the lamp access panel	28
Photo 18: Lamp access panel removed	28
Photo 19: #10-32 thumb nut on heat sink	29
Photo 20: Removing the high voltage lead from the heat sink	29
Photo 21: Heat sink unscrewed from socket	30
Photo 22: Heat sink and lamp removed	30
Photo 23: Lamp focus adjustment mechanisms (Access panel removed)	32
Photo 24: Lamp run under reverse polarity	36

TABLES

Table 1: Performance Specifications	6
Table 2: General Specifications	7
Table 3: Certifications	7
Table 4: Riser Assemblies	15
Table 5: Newport Breadboard Mount Solutions	15
Table 6: Air Mass Filters	17
Table 7: Troubleshooting Guide	36
Table 8: Products and Accessories	41

1 INTRODUCTION

Congratulations for choosing an Oriel® Class ABB Solar Simulator!

With over 45 years of proven performance and rugged durability built into our solar simulator product family, NEWPORT Corporation's Oriel® Sol1A™ Class ABB systems take solar simulation to the next level. These large area sources use a xenon lamp and proprietary filter that efficiently and reliably meets Class ABB performance parameters without compromising the 1 SUN output power. The result is a cost-effective and rugged system, backed by our global service and support network.

2 FEATURES AND SPECIFICATIONS



Photo 1: Sol1A™ Solar Simulator and Power Supply

2.1 Components Included

Each system includes:

- An illuminator with a built-in arc lamp ignitor;
- An arc lamp power supply (69907 for 150W lamps, 69920 for 450W and 1kW lamps, and 69922 for 1.6kW lamps);
- An arc lamp;
- Heat Sink;
- Lamp Socket Adaptor;
- All necessary adapters and cables;
- Air mass filter(s) in black case;
- AC Line Cords (2) correct for the AC main in the destination country;

2.2 Electrical Specifications

AC INPUT:

- 95-264VAC, 47-63Hz; 3A maximum current for simulator
- 95-264VAC, 47-63Hz; 12A maximum current for [69907 & 69920 power supply](#)
- 190-264VAC, 47-63Hz; 15A maximum current for [69922 power supply](#)

2.3 Specifications and Certifications

PERFORMANCE SPECIFICATIONS

PARAMETER	94021A	94041A	94061A	94081A
Nominal Lamp Electrical Power (W) ¹	150	450	1000	1600
Illumination Area (in.) [mm]	2 x 2 [50 x 50]	4 x 4 [100 x 100]	6 x 6 [150 x 150]	8 x 8 [200 x 200]
Maximum Angle of Incidence (°)	< ± 6	< ± 4	< ± 3	< ± 2
Nominal Working Distance (in.) [mm]	2.0 [50]	6.0 [150]	7.0 [180]	15.0 [380]
Typical Output Power	100 mW / cm ² (1 SUN)			

Table 1: Performance Specifications

GENERAL SPECIFICATIONS

PARAMETER	94021A	94041A	94061A	94081A
Weight lbs. [kg]	65.0 [29.5]	70.0 [32]	75.0 [34]	130.0 [59]
Dimensions inches [mm] Height (not including risers)	19.9 [507]	19.0 [483]	19.0 [483]	20.4 [518]
Width (not including fan assembly)	18.7 [474]	29.8 [758]	35.5 [901]	38.3 [974]
Depth	9.5 [241]	12.8 [324]	12.8 [324]	15.5 [394]
Operating Temperature Range (°C)	20 to 30			
Storage Temperature Range (°C)	-40 to 70			
Humidity	< 45%, relative, non-condensing			

Maximum Input Power Specifications For lamp housing	-	250 VAC, 1A, 47-63 Hz	250 VAC, 1A, 47-63 Hz	250 VAC, 1A, 47-63 Hz
For power supply	264 VAC, 12A, 47-63 Hz	264 VAC, 12A, 47-63 Hz	264 VAC, 12A, 47-63 Hz	264 VAC, 15A, 47-63 Hz

Table 2: General Specifications

CERTIFICATIONS

Parameter	
CE Certification	Yes
Spectral Irradiance scan ²	250 – 1700 nm at 1 SUN without a filter installed and subsequent scan(s) with the ordered filter(s) installed
Spectral Match Classification	A- IEC 60904-9 (2007), ASTM E927-10, JIS 8904-9 (2017)
Uniformity Classification	B- IEC 60904-9 (2007), ASTM E927-10, JIS 8904-9 (2017)
Temporal Stability Classification	B- IEC 60904-9 (2007), ASTM E927- 10, JIS 8904-9 (2017)

Table 3: Certifications

NOTES

1. ±20% adjustable power from lamp rated power without adverse performance via power supply.
2. Provided with the Class ABB test data on the USB thumb drive.

Below is an example of a calibration certificate that will be included with each Sol1A.

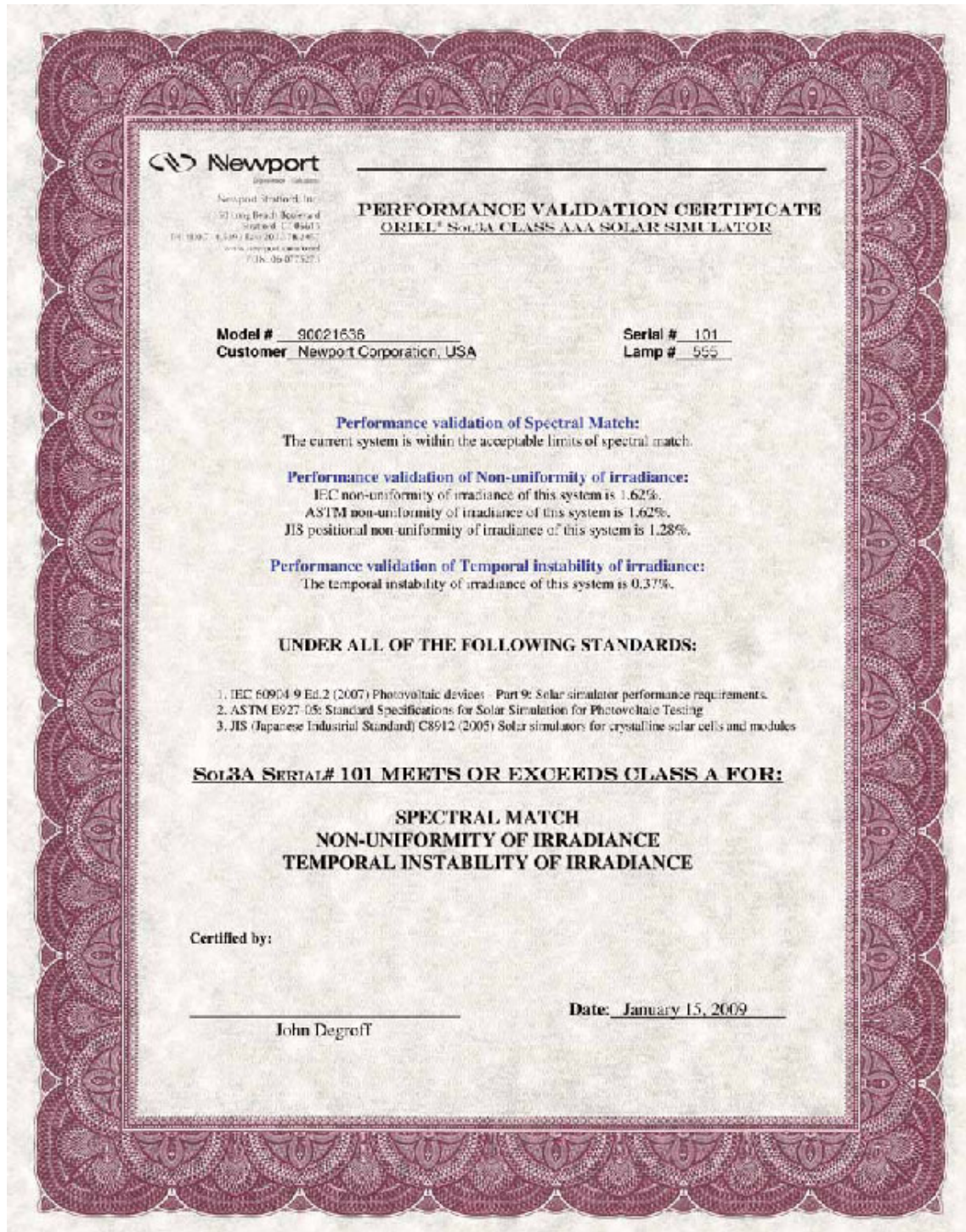

Figure 1: Performance Validation Certificate for ORIEL® Sol1A™

3 SAFETY

DO NOT OPERATE THIS EQUIPMENT UNTIL YOU HAVE READ THIS MANUAL!

THE HAZARDS ASSOCIATED WITH THE OPERATION OF THIS EQUIPMENT FALL INTO THE FOLLOWING FOUR CATEGORIES:

- **ELECTRICAL HAZARDS**
- **ULTRAVIOLET RADIATION HAZARDS**
- **LAMP HAZARDS**
- **AND TRANSIENT EMI HAZARDS**

DURING NORMAL OPERATION AND IN ACCORDANCE WITH THE PRECAUTIONS PRESENTED IN THIS MANUAL, NONE OF THESE HAZARDS PRESENT A PROBLEM.

3.1 Electrical Hazards

There is no hazard during **normal** operation. **Normal operation** means that the power supply and illuminator are operated at the **specified** current and voltage, with their covers properly in place and all cables correctly connected.

Incorrect connection of the cables is hazardous to the equipment and can result in violent lamp explosion!

The power supply provides voltages and currents that could be **lethal**. Do not operate the power supply unless it and the illuminator are properly cabled.

Do not remove the power supply cover and turn it on! The power supply cover should **only** be removed by a qualified electronics technician experienced with high-voltage power supplies.

The illuminator produces very high internal voltages. A transient ignition pulse of several kilovolts is used to start the lamp. This voltage, under certain circumstances, could be **lethal**.

The illuminator is equipped with an interlock switching system.

- DO NOT attempt to circumvent this system.
- DO NOT operate the illuminator with any access to the interior of the housing.

For complete instructions on proper operation, read all of this manual as well as the Power Supply Manuals ([69907](#) for use with 150W, [69920](#) for use with 450W and 1kW, and the [69922](#) for use with the 1.6kW).

3.2 Ultraviolet Radiation Hazards

This unit produces high intensity ultraviolet (UV) radiation. This radiation can cause **severe burns** to skin and the outer layers of the eye which may not become apparent for hours or even days after exposure.

As with sunlight, there is a risk of ***melanoma*** (skin cancer) as well as the formation of cataracts with repeated exposure.

Under normal operating conditions, the user receives minimal UV exposure even over long periods of operation. However, certain precautions should always be taken when operating this equipment:

- Always avoid exposure to the direct, reflected, or diffuse radiation from the lamp or the unit itself.
- Always wear UV-blocking glasses, goggles or other face shielding during operation.
- Always wear protective clothing and gloves if it is necessary to be exposed to the direct beam, even if only for a few seconds.

For a list of Newport-recommended UV protection solutions, please refer to Table 7.

3.3 Ozone

Ultraviolet light reacts on a molecular level with the atmosphere to produce **ozone** that is vented from the housing during normal operation by the cooling fans. When this exhaust is vented into an enclosed area, the ozone concentration can build up beyond the recommended 1 ppm exposure level.

Ozone is considered toxic and can induce headaches, nausea, and flu-like symptoms. For people with chronic respiratory conditions such as asthma, extremely high levels of ozone can pose a serious health hazard. Susceptibility varies significantly from individual to individual.

Fortunately, ozone has a distinctive odor. If this smell is noticed persistently in an area remote from the fans, it is recommended to check the ozone levels with a test kit and improve the ventilation of the area.

It is the user's responsibility to ensure that the equipment is operated in an area with adequate ventilation or provide other means for eliminating excessive levels of ozone, such as an Oriel model 66087 Ozone Eater or direct outside exhaust.

3.4 Lamp Hazards

The arc lamps used in this illuminator are filled with rare gas at high pressure. There is always a danger of lamp explosion due to mechanical failure. This is particularly true when the lamp is operating, since the internal pressure can reach tens of atmospheres. Thermal strains can cause the lamp to explode under certain conditions.

- **Never touch the lamp with bare fingers or other contaminants.** Skin oil or other substances can burn into the lamp envelope and weaken its structure.
- Always wear appropriate gloves and impact-resistant goggles when handling the lamp.
- Avoid any mechanical strain during handling.
- DO NOT operate the lamp unless all housing panels are in place.
- Arc lamps become very hot (up to 220°C) after only a few minutes of operation, and remain quite hot for at least 25-30 minutes after being turned off.
- If the Arc Lamp is turned off, do not attempt to restart the lamp until the lamp has completely cooled. Lamp life may be significantly reduced by failure to adequately cool it.

3.5 Electromagnetic Interference (EMI)

Ignition of an arc lamp requires a high voltage pulse. This pulse is a source of EMI - both radiated and conducted. **Good grounding, cable routing practice, and EMI shielding** may be necessary to protect sensitive circuitry from this ignition pulse.

It is suggested to start the arc lamp before powering up nearby computer equipment. Keep computers and other sensitive electronic devices at least six feet (1.8 meters) away from the light source.

Summary of Precautions:

- Always wear UV protective goggles and gloves;
- Never look directly into the output beam;
- Never look at the specular reflection of the beam;
- Never handle an arc lamp with bare hands;
- Never apply torque to the lamp;
- Always provide adequate ventilation;
- Always operate the unit with all covers fully in place;
- Never try to override the safety interlocks;
- Sol1A solar simulators are not designed for human research studies.

4 SETTING UP THE SYSTEM

4.1 Unpacking the System

Remove all items from the shipping containers and verify that the primary items as well as any optional accessories that you ordered are accounted for by cross-checking the contents against the packing slip.

Be sure to retain all packing materials for shipment of the product back to the company for service and/or recertification.

Each system includes:

- Illuminator housing with a built-in arc lamp ignitor;
- Arc lamp power supply;
- Arc lamp;
- Heat sink;
- Lamp socket adaptor;
- All necessary adapters and cables;
- Air mass filter(s) in black case;
- AC Line Cords (2) correct for the AC main in the destination country
- Check to ensure the serial number on the lamp box matches the serial number reported on the certificate. If multiple lamps have been purchased, all may have the same referenced model number but should have unique serial numbers. Note that only one lamp was used to certify the simulator by the factory.
- If any items are missing or damaged, contact your NEWPORT sales representative immediately.



Photo 2: Lamp and heat sink (with packing crate)



Photo 3: Air mass filter assembly (stored in case)



Photo 4: Unpacked components



Photo 5: Simulator and power supply unpacked

4.2 MOUNTING THE SYSTEM

When removing the Sol1A from the crate be careful when placing it on a surface as it has a center of gravity shifted to the front of the unit and can easily tip. Be certain to support the unit temporarily until it is permanently mounted to a work surface.

See Appendix A for dimensional drawings to determine how your Sol1A solar simulator will be mounted to accommodate your test fixture.

Note: The following model comes with risers from the factory due to its working distance:

Solar Simulator Model	Riser Assembly Factory PN
94061A	603873

Table 4: Riser Assemblies

See [Table 1: Model Information](#) for required working distances to achieve Class B uniformity.

SAFETY NOTE:

[Section II. SAFETY](#) details the hazards associated with this equipment.

When setting up and operating illuminators you MUST:

- Wear eye protection;
- Wear gloves;
- Cover all exposed skin;
- Make sure the housing and power supply are unplugged from the AC line.

It is recommended that the Solar Simulator be mounted to an optical table or breadboard. The following table provides a few Newport mounting solutions for each model:

Model	Base Plate Dimensions	Breadboard Solution	Full Length Dimensions	Breadboard Solution
94021A	7.75" x 9.50"	SA2-08X10	18.65" x 9.50"	SA2-12
94041A	12.75" x 12.31"	SA2-18X18	29.83" x 12.75"	Sa2-18x30
94061A	12.75" x 12.31"	SA2-18X18	35.46" x 12.75"	SA2-18X36
94081A	15.50" x 16.26"	SA2-18X18	38.34" x 15.50"	SA2-24

Table 5: Newport Breadboard Mount Solutions

4.3 Installing Filters

Remove the side cover of the output assembly to inspect the lens, mirror, and front surface of the beam homogenizer for shipping damage as shown in Figure 2. If any optical surface requires cleaning, refer to [section V.2 Cleaning Optics](#) in this manual for more details.

Solar simulators include **spectral correction filters (Air Mass filters)**, which correct the light output to closely match the solar spectrum under varying conditions. This section discusses these filters and how to properly install them in your unit. The Sol1A simulators include an **AM1.5G Filter** standard with the system as shown below. The filter is shipped in its own case. Note that the solar simulator should never be transported with the filter in place. Save this case for storage of the filter. A label indicates which side must face away from the lamp.

To install the filter, remove the side cover of the output assembly, insert the filter into Position A until it sets into the detents, and secure the cover panel back to the housing.

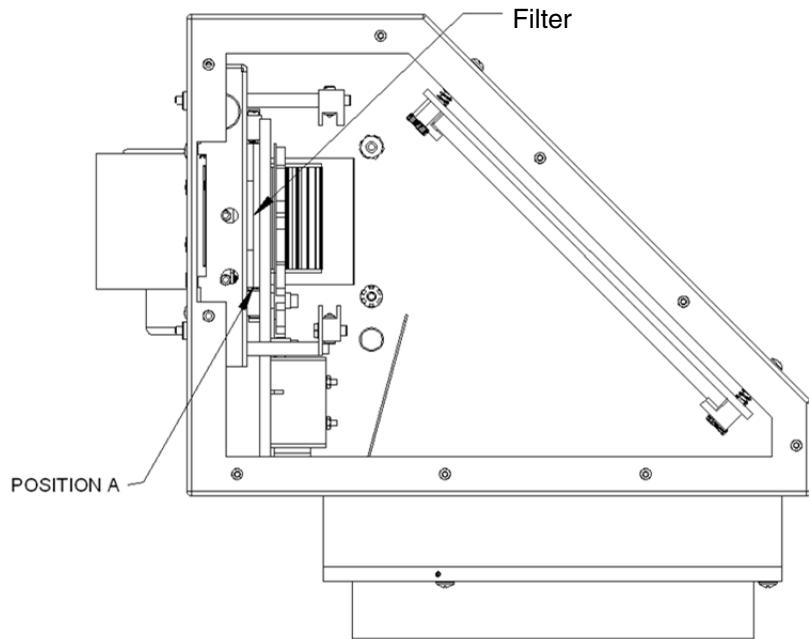

Figure 2: Proper installation of air mass filters for various models

Alternate Air Mass Filters can be installed in the Sol1A series to simulate conditions other than AM1.5G.

Air Mass Filter Type	Function	Model No(s).
AM 0	Corrects the output of a xenon lamp to better match the solar spectrum found outside the earth's atmosphere.	81311
AM 1.5 Direct	Simulates the direct solar spectrum when the SUN is at a zenith angle of 37.0° (ASTM E891).	81389

Table 6: Air Mass Filters

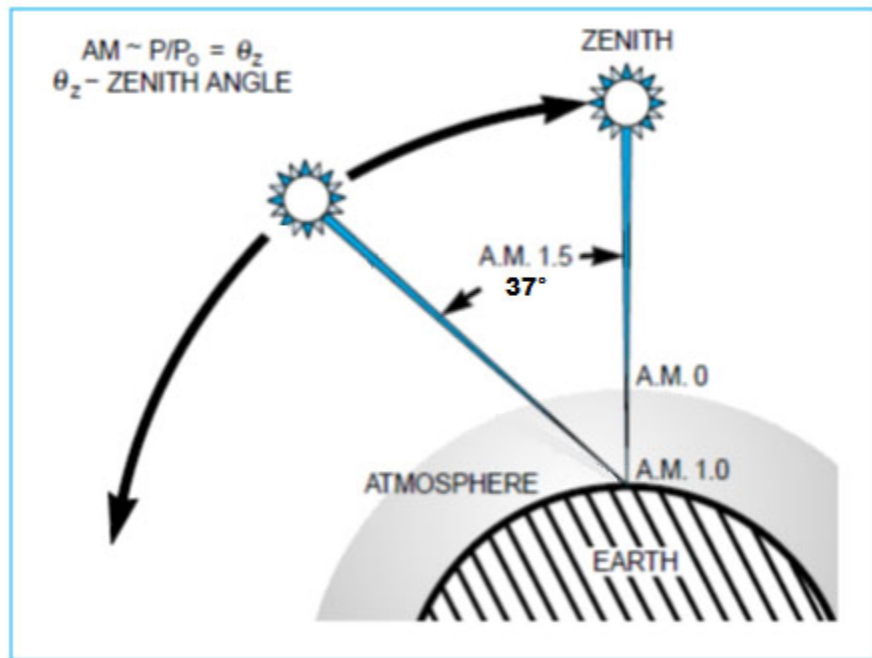

Figure 3: Air Mass Definitions

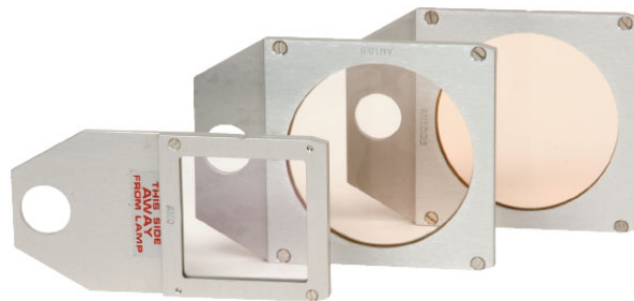

Photo 6: Air Mass Filters: AM0 (2"x2"), AM1.5D filters (2"x2")

Proper installation placement of other Air Mass filters for various simulator models is the same location (Position A) as the standard AM 1.5G filter.

4.4 Lamp Access/ Removing Panels

Remove the top side cover of the lamp housing, which is referred to as the lamp access panel, by unscrewing all the panel screws and lifting the panel from the housing. Carefully inspect the ellipsoidal reflector, primary mirror, and rear surface of the beam homogenizer for any damage that may have been caused during shipping. If any optical surface requires cleaning, refer to [section V.2 Cleaning Optics](#) in this manual for more details.

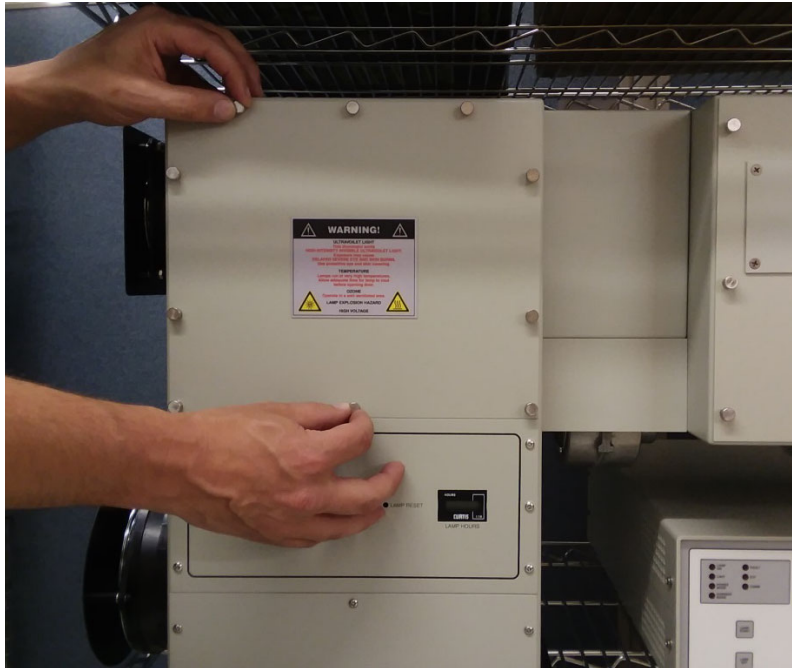

Photo 7: Removing the lamp access panel

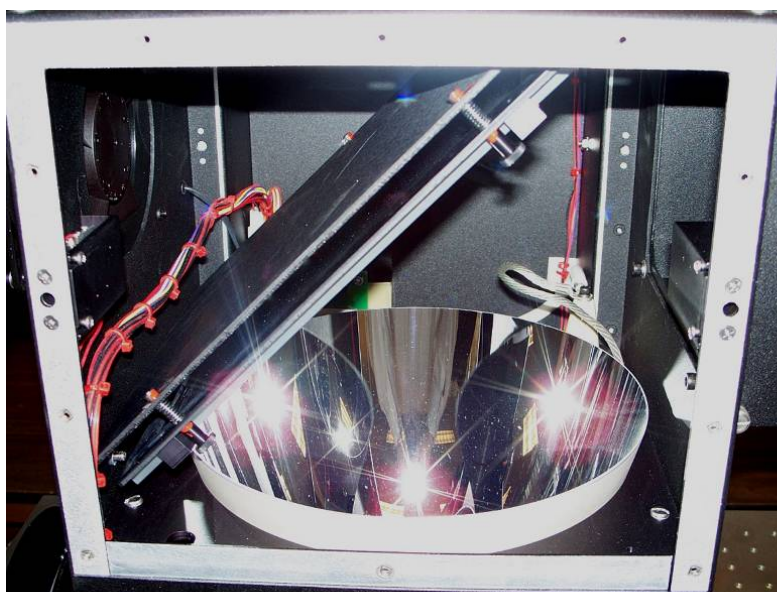

Photo 8: Lamp access panel removed

4.5 Installing the Lamp

4.5.1 Installing the 150W Lamp

CAUTION

- Always wear appropriate gloves and impact-resistant goggles when handling the lamp. Refer to Table 7 for a list of Newport-recommended options.
- Avoid undue stress on the glass portion of the lamp (protecting both the seals and envelope) to minimize the chance of catastrophic lamp failure. Use only your fingers when the lamp is held at one end and you are exerting a force on the other end.
- Lamp orientation is **critical**. Xenon lamps are designed to operate with the anode (+) end pointing upwards.
- If your lamp has a “starter” wire in place; do not remove it from the lamp.

1. Locate the 150W Heat Sink Assembly (PN 6255-ADAPTER-KIT) consisting of the brass lamp threaded adapter (PN 90015772) and lamp adapter (PN 90015771).
2. Remove the lamp from its container and check to make sure that the envelope is clean (if necessary, clean it using denatured alcohol and lint-free tissues).
3. Screw the brass threaded adapter onto the cathode of the lamp (- endcap).
4. Place the lamp adapter over the exposed + endcap, ensuring that the endcap inserts fully into the adapter. Tighten the thumb nut to secure the adapter to the lamp.
5. Hold the lamp by the adapter and place the threaded end through the ellipse into the socket. Screw the lamp into the socket, being careful not to over tighten. **Use fingers only – DO NOT use any tool to tighten the lamp in the socket** as this could over stress the envelope and seals, resulting in catastrophic lamp failure.

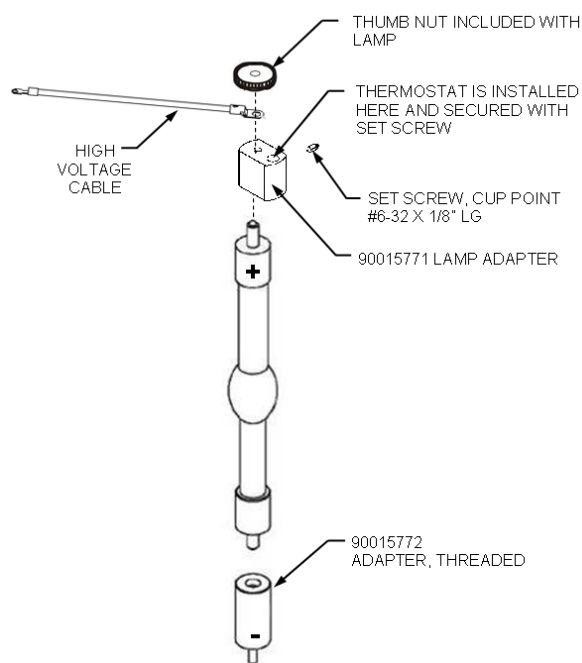

Figure 4: Installing the 150W Lamp



Photo 9: 150W Lamp with adapter attached

4.5.2 Installing the 450W Lamp

CAUTION

- Always wear appropriate gloves and impact-resistant goggles when handling the lamp. Refer to Table 7 for a list of Newport-recommended options.
- Avoid undue stress on the glass portion of the lamp (protecting both the seals and envelope) to minimize the chance of catastrophic lamp failure. Use only your fingers when the lamp is held at one end and you are exerting a force on the other end.
- Lamp orientation is critical. Xenon lamps are designed to operate with the anode (+) end pointing upwards.
- If your lamp has a “starter” wire in place; do not remove it from the lamp.

6. Locate the 450W Heat Sink Assembly (PN 90023031) consisting of the brass lamp threaded adapter (PN 8071-2-1005-2) and heat sink (PN 90015859).
7. Remove the lamp from its container and check to make sure that the envelope is clean (if necessary, clean it using denatured alcohol and lint-free tissues).
8. Place the brass threaded adapter on the cathode of the lamp (- endcap). Tighten the set screws to secure it in place.
9. Place the heat sink over the exposed + endcap, ensuring that the endcap inserts fully into the heat sink. Tighten the two #10-32 set screws with the provided hex wrench to secure the heat sink to the lamp.
10. Hold the lamp by the heat sink and place the threaded end through the ellipse into the socket. Screw the lamp into the socket, being careful not to over tighten. **Use fingers only – DO NOT use any tool to tighten the lamp in the socket** as this could over stress the envelope and seals, resulting in catastrophic lamp failure.

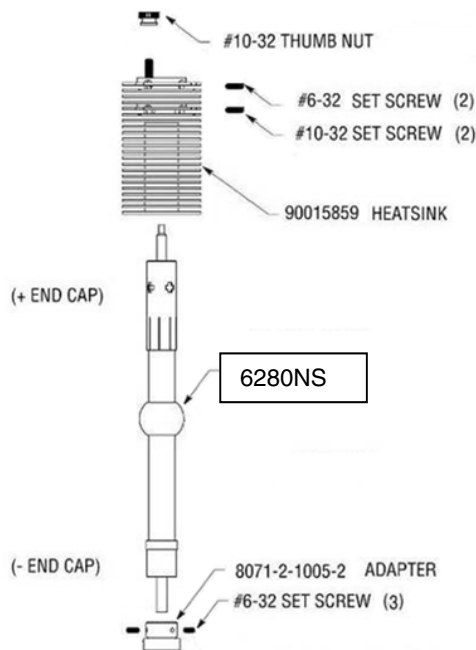

Figure 5: Installing the 450W Lamp



Photo 10: 450W Lamp with heat sink attached

4.5.3 Installing the 1.0kW Lamp

CAUTION

- Always wear appropriate gloves and impact-resistant goggles when handling the lamp. Refer to Table 7 for Newport-recommended options.
- Avoid undue stress on the glass portion of the lamp (protecting both the seals and envelope) to minimize the chance of catastrophic lamp failure. Use only your fingers when the lamp is held at one end and you are exerting a force on the other end.
- Lamp orientation is critical. Xenon lamps are designed to operate with the anode (+) end pointing upwards.
- If your lamp has a “starter” wire in place; do not remove it from the lamp.

1. Locate the 1.0kW Heat Sink Assembly (PN 90023032) consisting of the brass lamp threaded adapter (PN 8071-2-1005-1), and heat sink (PN 90026578).
2. Remove the lamp from its container and check that the envelope is clean (if necessary, clean it using denatured alcohol and lint-free tissues).
3. Place the brass threaded adapter on the cathode of the lamp (- endcap). Tighten the #6-32 set screws to secure the adapter to the lamp.
4. Place the heat sink over the exposed + endcap, ensuring that the endcap inserts fully into the heat sink. Tighten the #6-32 socket head cap screw to secure the heat sink to the lamp.
5. Hold the lamp by the heat sink and place the threaded end through the ellipse and into the socket. Screw the lamp into the socket, being careful not to over tighten. **Use fingers only - do not use any tool to tighten the lamp in the socket** as this could over stress the envelope and seals, resulting in catastrophic lamp failure.

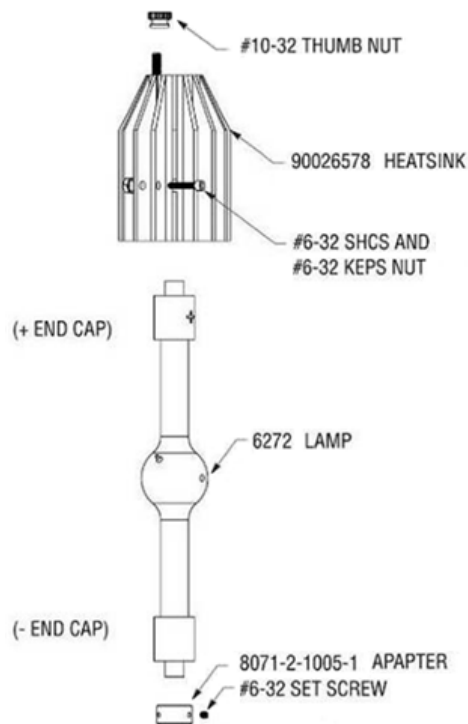

Figure 6: Lamp Assembly for 1kW



Photo 111: 1kW lamp with heat sink attached

4.5.4 Installing the 1.6 kW Lamp

CAUTION

- Always wear appropriate gloves and impact-resistant goggles when handling the lamp. Refer to Table 7 for Newport-recommended options.
- Avoid undue stress on the glass portion of the lamp (protecting both the seals and envelope) to minimize the chance of catastrophic lamp failure. Use only your fingers when the lamp is held at one end and you are exerting a force on the other end.
- Lamp orientation is critical. Xenon lamps are designed to operate with the anode (+) end pointing upwards.
- This lamp has a “starter” wire in place; do not remove it from the lamp.

1. Locate the 1.6kW Heat Sink Assembly (PN 90026576) consisting of the brass lamp threaded adapter (PN 8071-2-1005-1) and heat sink (PN 90026577).
2. Remove the lamp from its container and check that the envelope is clean (if necessary, clean it using denatured alcohol and lint-free tissues).
3. Place the brass threaded adapter on the cathode of the lamp (- endcap). Tighten the #6-32 set screws to secure the adapter to the lamp.
4. Place the heat sink over the exposed + endcap, ensuring that the endcap inserts fully into the heat sink. Tighten the #6-32 socket head cap screw to secure the heat sink to the lamp.
5. Hold the lamp by the heat sink and place the threaded end through the ellipse and into the socket. Screw the lamp into the socket, being careful not to over tighten. **Use fingers only - do not use any tool to tighten the lamp in the socket** as this could over stress the envelope and seals, resulting in catastrophic lamp failure.

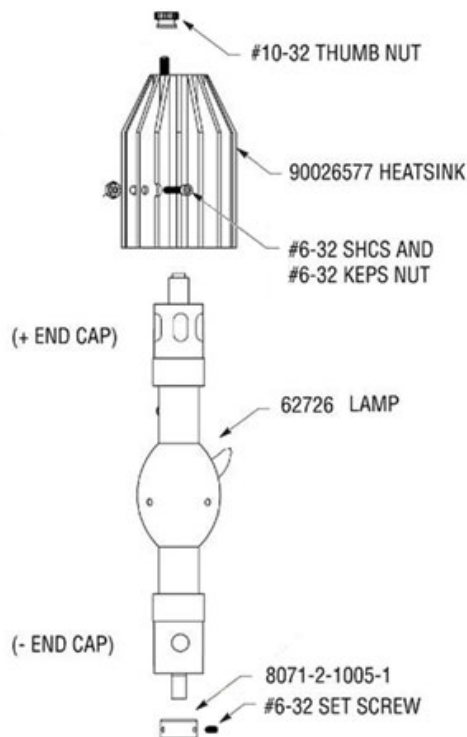

Figure 7: Installing the 1.6kW Lamp

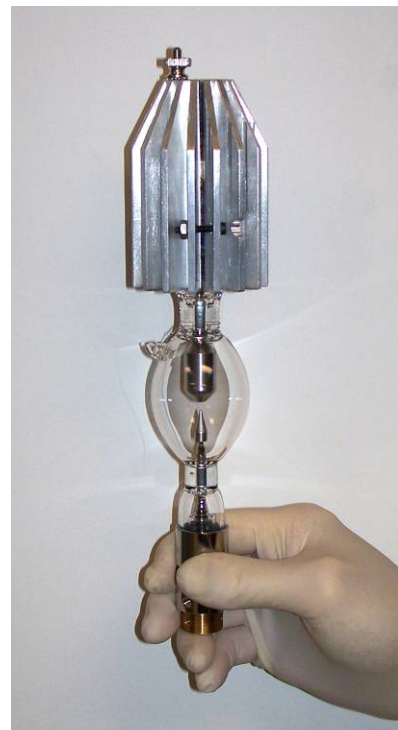

Photo 122: 1.6 kW lamp with heat sink attached

4.6 ELECTRICAL CONNECTIONS

There are two cables that connect the [69907](#) / [69920](#) / [69922](#) power supply to the illuminator housing. One cable has a **black** connector on each end (**70050**) while the other has a **gray** connector on each end (**70051**). The receptacles for these connectors are clearly marked on both the power supply and the housing. Make sure the connectors are firmly seated and that the jack screws are finger tight.

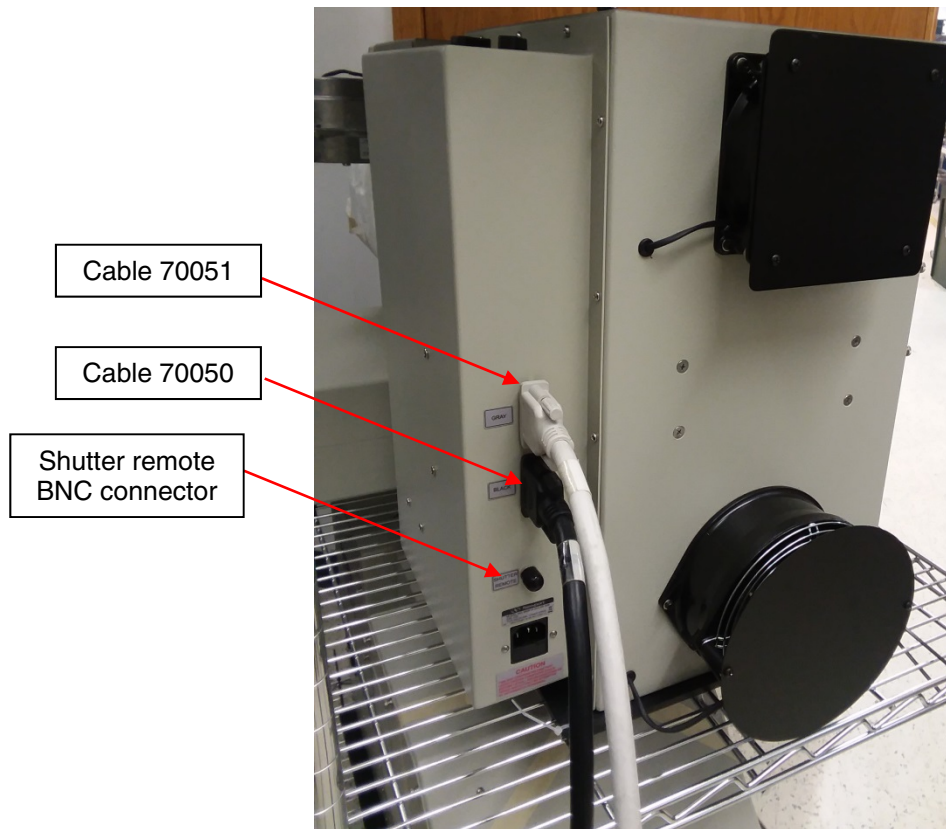

Photo 133: Electrical connections on simulator (black and gray cables)

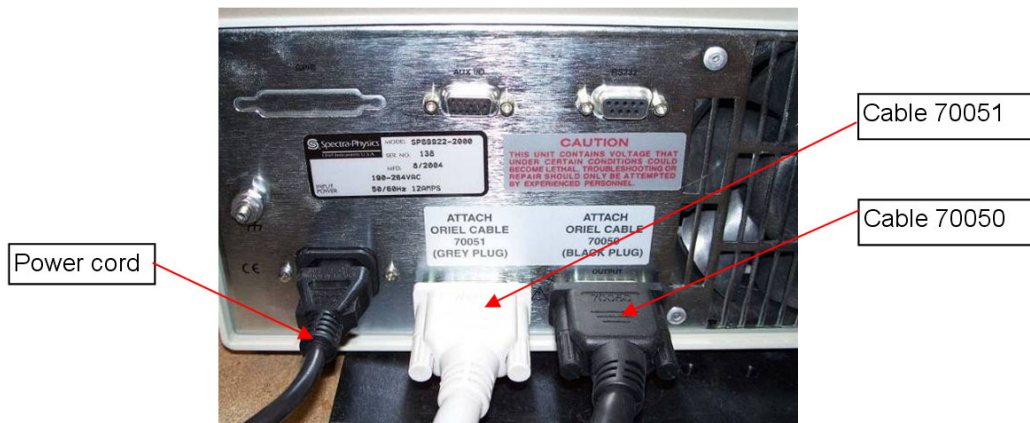

Photo 144: Electrical connections on power supply (black and gray cables)

The BNC connector on the housing labeled “SHUTTER REMOTE” is the connection to be used for the optional hand-held foot switch shutter controller, or the optional digital controller. If a **Digital Exposure System** is in the system, please refer to the [Digital Exposure System Manual](#) for set-up instructions.

The remaining connector on the housing is for the AC line cord. The AC input is universal (it auto senses the input voltage so no configuration is required for line voltages within the specification limits) and will operate between 95-265VAC and 47-63Hz.

Avoid using an outlet strip for powering the solar simulator since the fans require the AC voltage to complete their 10 minute time-out. This time-out is required in order to properly cool the lamp after power is turned off.

4.7 ILLUMINATOR HOUSING CONTROLS

Take a few minutes to familiarize yourself with the illuminator housing control panel.

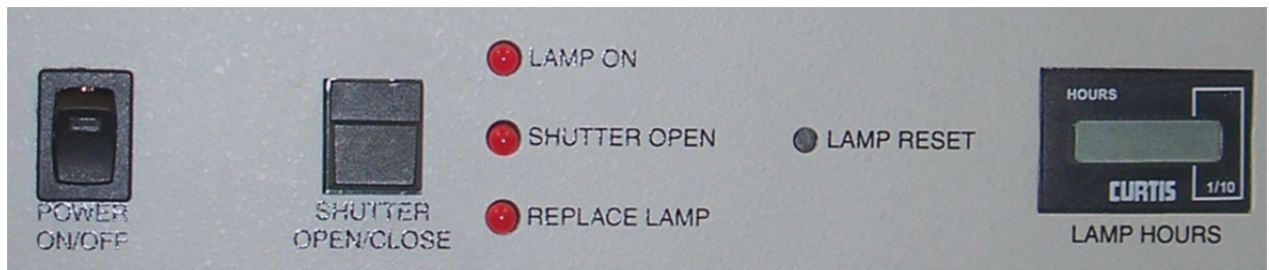

Photo 155: The illuminator housing control panel

The **POWER ON/OFF** button energizes the illuminator control panel, providing power to activate the shutter. Even when this switch is OFF, there may be hazardous voltages present in the REAR compartment of the illuminator. This area is not accessible under normal use and presents no hazard to the operator.

The **SHUTTER OPEN/CLOSE** switch manually activates the shutter. This button replicates the function of the optional hand-held or foot-activated remote switch.

NOTE: If the front panel shutter switch is depressed, the remote input will have no effect. Similarly, if the remote input is active (TTL high), the front panel shutter switch has no effect.

The **LAMP HOURS meter (ETI)** indicates the cumulative lamp hours since the last lamp change.

The **LAMP RESET button** resets the ETI to zero and turns OFF the REPLACE LAMP indicator LED.

NOTE: The lamp housing power must be plugged in to reset the ETI.

The **REPLACE LAMP light** will come on when the lamp has undergone approximately 90% of the manufacturer's expected lifetime. This does not imply that the lamp's spectral performance meets Class A spectral performance at this level of usage. **LAMP LIFE WILL DIFFER DEPENDING ON THE LEVEL OF USE.** This is especially true if you are operating the lamp at a power different from the nominal power or if your application requires more frequent lamp changes.

Note that this indicator is only a visual aid and should be used in conjunction with reading the ETI display.

The **SHUTTER OPEN light** is lit when the shutter is open.

The **LAMP ON light** is lit when the lamp is energized. Note that this light may stay on for a short time after the lamp is turned off because the lamp electrodes are still glowing enough to activate the photo sensor.

5 USING THE SYSTEM

5.1 SETTING UP THE POWER SUPPLY

Your simulator and power supply were set up and run as a system to certify its performance. The correct power supply settings for your system including operating power and maximum power limits are stored in the power supply.

Refer to the Power Supply Manuals ([69907](#), [69920](#) and [69922](#)) for information on modifying the power supply settings.

5.2 SHUTTER CONTROL

The shutter can be manually controlled using the housing control panel or via a TTL signal through the BNC input connector on that panel.

5.3 STARTING THE LAMP

1. Verify that all connections are properly in place according to [section III.4 Installing the Lamp](#). Also verify that all access panels are in place.
2. Turn ON the illuminator power switch and verify that the shutter switch activates the shutter. **Be sure to leave the shutter in the closed position before proceeding.**
3. Turn ON the power supply.
4. Your power supply has been factory set for your Sol3A and is operating in the constant power mode. The power limit has been set to 10% above the nominal lamp power. Your system has been factory configured to yield one SUN at the working plane after a 30 minute warm-up period. Lamp life may be significantly shortened if the lamp is operated outside the range of +10% to -20% of the nominal lamp rating.
5. Push the LAMP START switch. The lamp should start. If it does not, wait a few seconds, and then try again. If the lamp does not ignite after several tries, refer to the Power Supply Manuals ([69907](#), [69920](#) and [69922](#)) and [section VI. TROUBLESHOOTING](#) of this manual.
6. Verify that all fans are operating. The fans come on at full speed about 10 seconds after the lamp starts. If any fan is not running, shut the system down and contact NEWPORT for assistance.

<p>NOTE: The fans will continue to run for about 15-20 minutes after the system is shut off in order to cool down the lamp. Do not turn off the Illuminator before the fans stop.</p>
--

5.4 POWER SUPPLY AND DIGITAL EXPOSURE SYSTEM

Refer to the Power Supply Manuals ([69907](#), [69920](#) and [69922](#)) for details on the power supply operation.

[The Digital Exposure System Manual](#) describes how to mount the detector/fiber pick-off and how to set up and operate the controller.

6 ROUTINE MAINTENANCE

Routine maintenance is necessary to ensure that your Class ABB Solar Simulator performs to specification. The following section outlines routine maintenance of the product and its components.

6.1 Lamp Replacement

To remove the old lamp:

1. Wait for the fans to stop running and for the lamp to cool (about 15-20 minutes)
2. Turn OFF and UNPLUG the power supply
3. Turn OFF and UNPLUG the illuminator.



Photo 166: The Illuminator (rear view)

4. Remove the lamp access panel from the housing by unscrewing all panel screws.

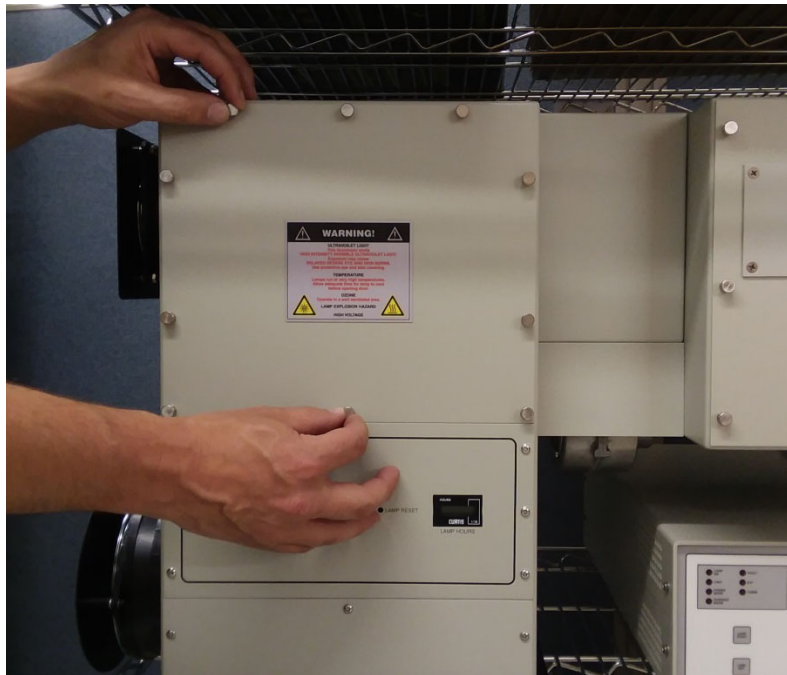

Photo 17: Removing the lamp access panel

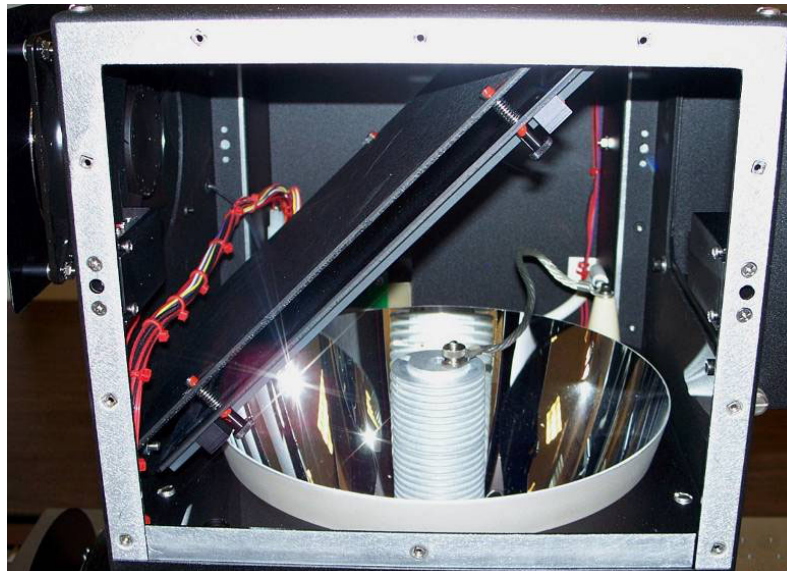

Photo 18: Lamp access panel removed

NOTE: Your lamp and heat sink may appear different than shown depending on your model of Sol1A™ Solar Simulator.

5. Loosen the #10-32 thumb nut, and remove from the threaded post atop the heat sink.

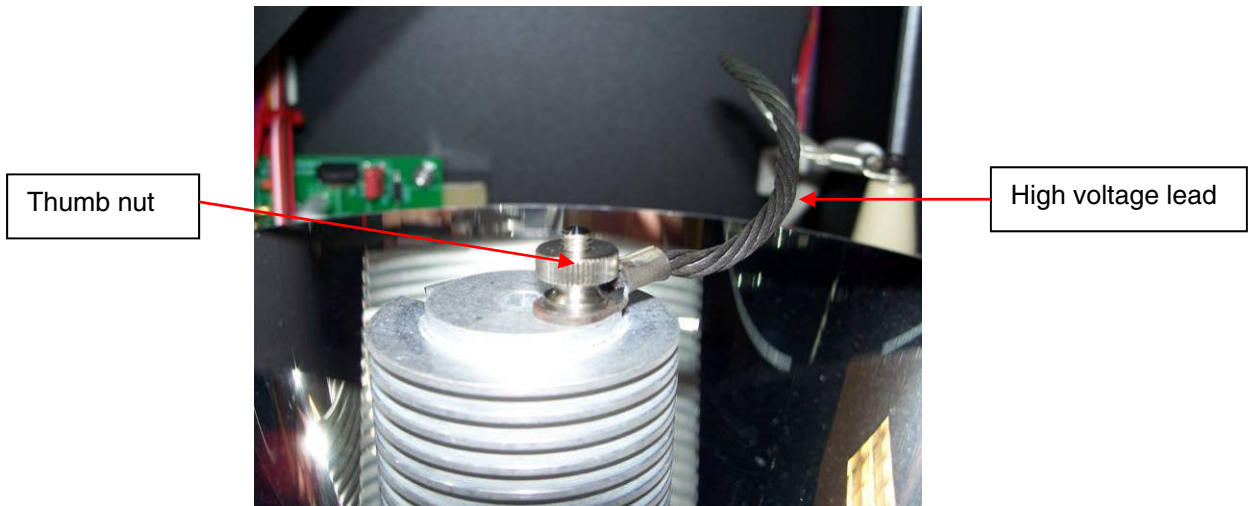

Photo 19: #10-32 thumb nut on heat sink

6. Remove high voltage lead from the heat sink.

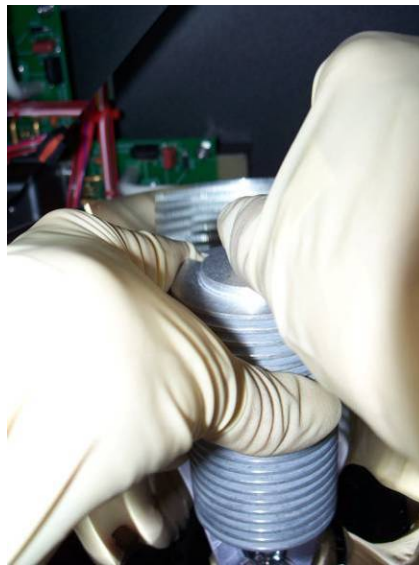

Photo 200: Removing the high voltage lead from the heat sink.

REMEMBER: Always wear appropriate gloves and impact-resistant goggles when handling the lamp. Refer to Table 7 for a list of Newport-recommended safety options.

7. Grasp the heat sink and unscrew the lamp from the socket (counterclockwise).



Photo 21: Heat sink unscrewed from socket

8. Remove the threaded adapter and the heat sink from the lamp endcap. [See sections [III.4.1](#), [III.4.2](#), and [III.4.3](#) for details removal of the adaptor and/or heat sink for the four different lamps.]
9. Inspect the optics to see if they require cleaning or replacement.
If cleaning or replacement is required, consult NEWPORT.

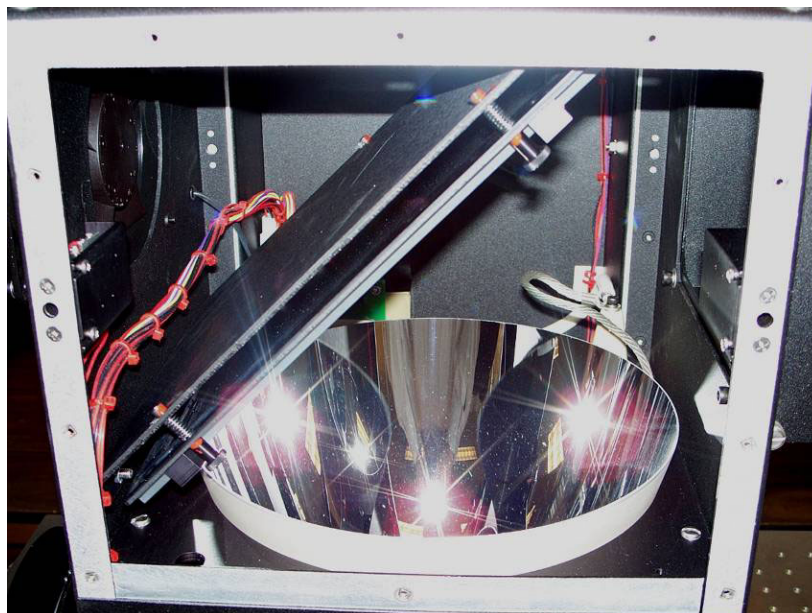

Photo 22: Heat sink and lamp removed

10. Install the new lamp, following directions detailed in [section III.4 Installing the Lamp](#). Refer to sections [III.4.1](#), [III.4.2](#), and [III.4.3](#) for details on installing the four different lamps.
11. Reconnect the AC line cord and turn ON the power switch on the illuminator control panel
12. Depress the “LAMP RESET” button using a small screwdriver or hex key. The “CHANGE LAMP” indicator should go out and the “LAMP HOURS” should reset to **zero**.

6.2 Lamp Alignment

Once a lamp is replaced it may need to be aligned. Unless the alignment settings are changed for some other reason, this procedure should **only** be performed when a new lamp is installed. We recommend using the 91150V calibrated reference cell and meter to insure 1 SUN at the working plane is achieved.

Although *it is default*, **Make sure the shutter is closed** before completing step 1.

1. Refer to the solar simulator test reports, which include the settings used when the system was tested and validated at the factory. Set-up the power supply to the operating power reported in these test reports. Start the lamp and allow it to warm up for at least 10 minutes.

NOTE: For desired results in measuring/testing stability, non-uniformity, or spectral match, the lamp should be allowed to warm-up for at least 30 minutes.

2. Remove the access panel from the lamp housing panel by loosening the panel screws and identify the adjustment mechanisms (knurled knobs (2) and ladder chain). The ladder chain helps to move the lamp position along the Z (vertical) axis, while the two knurled knobs help to change the position of the lamp in the XY (horizontal) plane but NOT particularly on the X and Y axes.

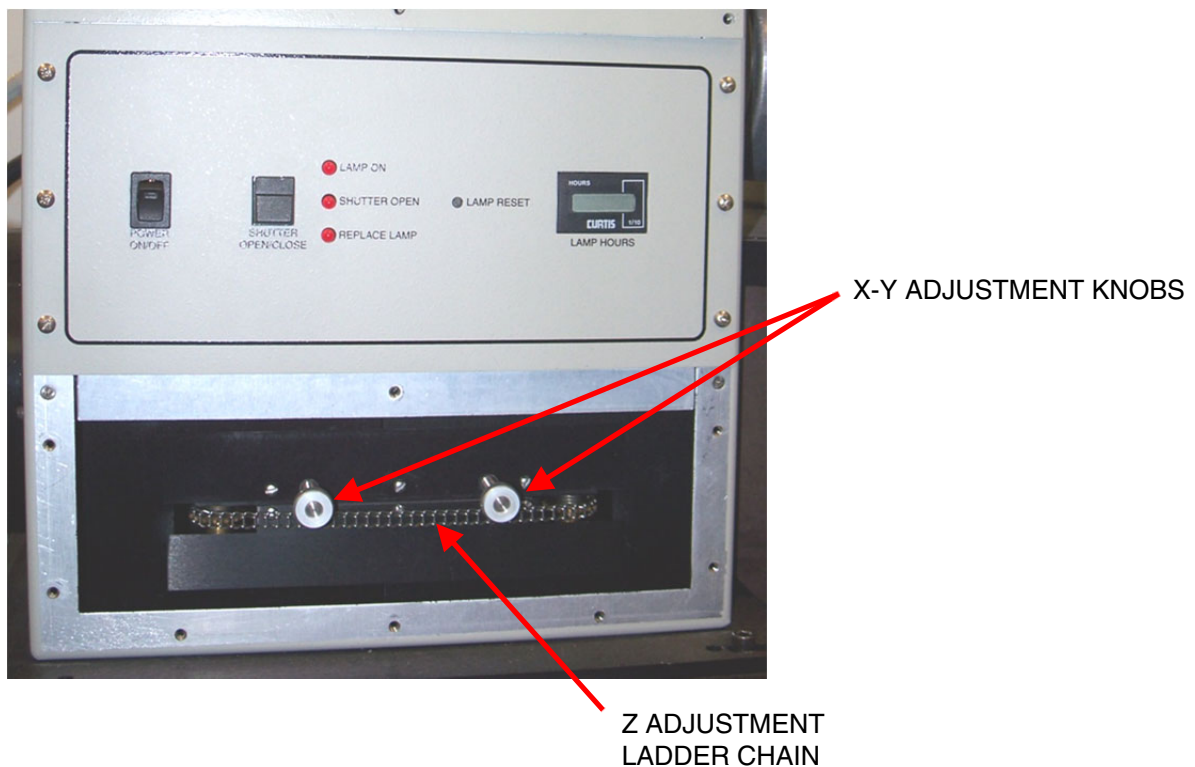

Photo 233: Lamp focus adjustment mechanisms (Access panel removed)

Place a calibrated reference cell in the exact optical center of the output at the recommended working distance from the lens vertex. Refer to [Table 1: Model Information/Optical Specifications](#) (for mounting purposes) of this manual to determine the appropriate working distance for your particular source.

1. Turn ON and zero your light intensity measuring device with the shutter of the simulator closed.

CAUTION

These sources produce intense ultraviolet, visible, and infrared radiation. Always wear adequate eye and skin protection when operating the system. Refer to Table 7 for Newport-recommended safety options.

2. Open the shutter of the Sol1A simulator and observe the reading.
3. Without changing any of the knob adjustments, adjust the ladder chain (Z-adjust) to obtain a maximum reading on the cell.

NOTE: The ladder chain can become quite warm during operation. While the temperature is not hazardous, you may find it more comfortable as well as easier to make this adjustment by inserting a small hex wrench or screwdriver into the chain and sliding it back and forth.

4. Close the shutter and allow the calibrated reference cell to cool down for approximately five minutes.
5. Open the shutter and turn one of the knurled knobs (X-Y adjust) to read maximum intensity on the calibrated reference cell. Knob adjustments fine tune the lamp position, so DO NOT turn knobs more than 2 rotations in either direction.
6. Adjust the second knurled knob for maximum intensity; to maintain the lamp position in the desired range, DO NOT turn the knob more than 2 rotations in either direction.
7. Close the shutter, allow the calibrated reference cell to cool, and repeat the three adjustments to verify the settings. At this point, to read the maximum intensity on the calibrated reference cell, one should adjust or make only minor changes to the ladder chain and knurled knobs.
8. Following the procedure stated above typically yields better uniformity, but not necessarily all the time. An operator may use their own procedures and insight to get best possible uniformity by adjusting the ladder chain and X-Y knobs. To be certain about % non-uniformity, the user should manually measure uniformity by using uniformity measurement tools or similar devices.
9. After achieving desired uniformity, close the shutter and replace the access panel.

NOTE: Your unit and lamp were rigorously tested at the NEWPORT facility by manually optimizing lamp position. Following the steps mentioned above will get your system close or within specification to meet percentage non-uniformity standards. In order to ensure your system's performance to meet percentage non-uniformity standards after installing/changing a lamp, you must make measurements on site EACH TIME A LAMP IS REPLACED by adjusting and optimizing the lamp position in order to achieve percentage non-uniformity within specifications of standards.

You may need to adjust the intensity to get 1 SUN (100mW/cm²). You can fine tune the power setting within the specified limits to achieve proper illumination.

6.3 Cleaning Optics

Newport recommends cleaning the optics only by using oil-free air or dry nitrogen to blow off contaminants. For additional cleaning, contact Newport to schedule a cleaning.

The optical components in the system may require removal in order to clean them. Since in most cases this requires partial disassembly of the housing, removal of these components should **ONLY** be performed by a qualified technician. Please contact NEWPORT for details.

7 TROUBLESHOOTING

PROBLEM	POSSIBLE CAUSE	ACTION
Lamp does not start	No power	Check that Simulator and Power Supply main power switches are turned on and cables from the power supply to the simulator housing are plugged in.
	Lamp not properly installed	Follow the lamp installation procedure carefully. Connections should be firm.
	Defective or marginal lamp	1. Repeat ignition sequence . 2. Replace lamp .
	Lamp has passed its usable lifetime	Replace lamp .
	Insulation breakdown	Consult NEWPORT.
	Interlock fault	1. Check for iLOC Error on power supply. Ensure lamp access panels are properly in place and that cables are seated at both ends. Check that the lamp housing is powered ON. 2. If lamp still does not start, Consult NEWPORT.
Shutter does not open	Damaged shutter, shutter mechanically jammed	Repair or replace shutter. <i>Consult Newport</i>
	Shutter actuation switch	Consult NEWPORT for replacement control board and switch.
	Defective shutter drive circuit	Consult NEWPORT.
Loss of power in output beam	Lamp out of focus	Follow instructions in lamp installation for optimization.
	Dirty optic	Clean optics .
	Damaged optic	Inspect all optics for damage and replace.
	Old lamp	Replace lamp .
Loss of beam uniformity	Lamp alignment	Align lamp .
Output unstable	Old lamp	Replace lamp .
	Lamp over/under driven	Run lamp at proper wattage only (nominal -20%, +10%)
	Improper use of Exposure Controller	Refer to Digital Exposure System Manual .

PROBLEM	POSSIBLE CAUSE	ACTION
Lamp explodes	Fingerprints on lamp	Replace lamp. BE SURE TO WEAR PROTECTIVE GLOVES WHEN INSTALLING NEW LAMPS.
	Old lamp	Replace lamp based on specified lamp lifetime .
	Incorrect lamp polarity	Make sure the lamp is installed correctly
	Lamp over driven	Run lamp at proper wattage only (nominal -20%, +10%).

Table 7: Troubleshooting Guide



Photo 244: Lamp run under reverse polarity

8 WARRANTY AND RETURNS

8.1 Contacting Oriel Instruments

Oriel Instruments belongs to Newport Corporation's family of brands. Thanks to a steadfast commitment to quality, innovation, hard work and customer care, Newport is trusted the world over as the complete source for all photonics and laser technology and equipment.

Founded in 1969, Newport is a pioneering single-source solutions provider of laser and photonics components to the leaders in scientific research, life and health sciences, photovoltaics, microelectronics, industrial manufacturing and homeland security markets.

Newport Corporation proudly serves customers across Canada, Europe, Asia and the United States through 9 international subsidiaries and 24 sales offices worldwide. Every year, the Newport Resource catalog is hailed as the premier sourcebook for those in need of advanced technology products and services. It is available by mail request or through Newport's website. The website is where one will find product updates, interactive demonstrations, specification charts and more.

To obtain information regarding sales, technical support, or factory service, United States and Canadian customers should contact Oriel Instruments directly.

Oriel Instruments
31950 E. Frontage Rd.
Bozeman, MT 59715 USA

Telephone: 877-835-9620 (toll-free in United States)
949-863-3144
Fax: 949-253-1680

Sales: orielPV.sales@newport.com
Technical assistance & Repair Service: orielPV.service@newport.com

Customers outside of the United States must contact their regional representative for all sales, technical support and service inquiries. A list of worldwide representatives can be found on Oriel's website: <https://www.newport.com/contact/contactslocations>

8.2 Request for Assistance / Service

Please have the following information available when requesting assistance or service:

- Contact information for the owner of the product.
- Instrument model number (located on the product label).
- Product serial number and date of manufacture (located on the product label).
- Description of the problem.

To help Oriel's Technical Support Representatives diagnose the problem, please note the following:

- Is the system used for manufacturing or research and development?
- What was the state of the system right before the problem?
- Had this problem occurred before? If so, when and how frequently?
- Can the system continue to operate with this problem, or is it non-operational?
- Were there any differences in the application or environment before the problem occurred?

8.3 Repair Service

This section contains information regarding factory service for this product. The user should not attempt any maintenance or service of the system beyond the procedures outlined in this manual. This product contains no user serviceable parts other than what is noted in this manual. Any problem that cannot be resolved should be referred to Oriel Instruments.

If the instrument needs to be returned for service, a Return Material Authorization (RMA) number must be obtained prior to shipment to Oriel Instruments. This RMA number must appear on both the shipping container and the package documents.

Return the product to Oriel Instruments, freight prepaid, clearly marked with the RMA number and it will either be repaired or replaced at Oriel's discretion.

Oriel is not responsible for damage occurring in transit. The owner of the product bears all risk of loss or damage to the returned products until delivery at Oriel's facility. Oriel is not responsible for product damage once it has left the facility after repair or replacement has been completed.

Oriel is not obligated to accept products returned without an RMA number. Any return shipment received by Oriel without an RMA number may be reshipped by Newport, freight collect, to the owner of the product.

8.4 Non-Warranty Repair

For products returned for repair that are not covered under warranty, Newport's standard repair charges shall be applicable in addition to all shipping expenses. Unless otherwise stated in Newport's repair quote, any such out-of-warranty repairs are warranted for ninety (90) days from date of shipment of the repaired Product.

Oriel will charge an evaluation fee to examine the product and determine the most appropriate course of action. Payment information must be obtained prior to having an RMA number assigned. Customers may use a valid credit card, and those who have an existing account with Newport Corporation may use a purchase order.

When the evaluation had been completed, the owner of the product will be contacted and notified of the final cost to repair or replace the item. If the decision is made to not proceed with the repair, only the evaluation fee will be billed. If authorization to perform the repair or provide a replacement is obtained, the evaluation fee will be applied to the final cost. A revised purchase order must be submitted for the final cost. If paying by credit card, written authorization must be provided that will allow the full repair cost to be charged to the card.

8.5 Warranty Repair

If there are any defects in material or workmanship or a failure to meet specifications, notify Oriel Instruments promptly, prior to the expiration of the warranty.

Except as otherwise expressly stated in Oriel's quote or in the current operating manual or other written guarantee for any of the products, Oriel warrants that, for the period of time set forth below with respect to each product or component type (the "Warranty Period"), the products sold hereunder will be free from defects in material and workmanship, and will conform to the applicable specifications, under normal use and service when correctly installed and maintained. Oriel shall repair or replace, at Oriel's sole option, any defective or nonconforming product or part thereof which is returned at the buyer's expense to the Oriel facility, provided, that the buyer notifies Oriel in writing promptly after discovery of the defect or nonconformity and within the Warranty Period. Products may only be returned by the buyer when accompanied by a return material authorization number ("RMA number") issued by Oriel, with freight prepaid by the buyer. Oriel shall not be responsible for any damage occurring in transit or obligated to accept products returned for warranty repair without an RMA number. Buyer bears all risk of loss or damage to the products until delivery at Oriel's facility. Oriel shall pay for shipment back to the buyer for products repaired under warranty.

WARRANTY PERIOD

All products (except consumables such as lamps, filters, etc) described here are warranted for a period of twelve (12) months from the date of shipment.

Lamps, gratings, optical filters and other consumables / spare parts (whether sold as separate products or constituting components of other products) are warranted for a period of ninety (90) days from the date of shipment.

WARRANTY EXCLUSIONS

The above warranty does not apply to products which are (a) repaired, modified or altered by any party other than Oriel; (b) used in conjunction with equipment not provided or authorized by Oriel; (c) subjected to unusual physical, thermal, or electrical stress, improper installation, misuse, abuse, accident or negligence in use, storage, transportation or handling, alteration, or tampering, or (d) considered a consumable item or an item requiring repair or replacement due to normal wear and tear.

DISCLAIMER OF WARRANTIES: EXCLUSIVE REMEDY

THE FOREGOING WARRANTY IS EXCLUSIVE AND IN LIEU OF ALL OTHER WARRANTIES. EXCEPT AS EXPRESSLY PROVIDED HEREIN, ORIEL MAKES NO WARRANTIES, EITHER EXPRESS OR IMPLIED, EITHER IN FACT OR BY OPERATION OF LAW, STATUTORY OR OTHERWISE, REGARDING THE PRODUCTS, SOFTWARE OR SERVICES. NEWPORT EXPRESSLY DISCLAIMS ANY IMPLIED WARRANTIES OF MERCHANTABILITY OR FITNESS FOR A PARTICULAR PURPOSE FOR THE PRODUCTS, SOFTWARE OR SERVICES. THE OBLIGATIONS OF ORIEL SET FORTH IN THIS SECTION SHALL BE ORIEL'S SOLE LIABILITY, AND BUYER'S SOLE REMEDY, FOR BREACH OF THE FOREGOING WARRANTY. Representations and warranties made by any person including distributors, dealers and representatives of Oriel / Newport Corporation which are inconsistent or in conflict with the terms of this warranty shall not be binding on Oriel unless reduced to writing and approved by an expressly an authorized officer of Newport.

8.6 Loaner / Demo Material

Persons receiving goods for demonstrations or temporary use or in any manner in which title is not transferred from Newport shall assume full responsibility for any and all damage while in their care, custody and control. If damage occurs, unrelated to the proper and warranted use and performance of the goods, recipient of the goods accepts full responsibility for restoring the goods to their original condition upon delivery, and for assuming all costs and charges.

9 PRODUCTS AND ACCESSORIES

ITEM	PART NUMBER	USED ON MODEL(S)
Xenon Lamp 150 W	6255	94021A
150W Heat Sink Assembly	90015771	94021A
Xenon Lamp 450 W	6279NS	94041A
450W Heat Sink Assembly	90023031	94041A
Xenon Lamp 1.0 kW	6272	94061A
1.0kW Heat Sink Assembly	90023032	94061A
Xenon Lamp 1.6 kW	62726	94081A
1.6kW Heat Sink Assembly	603760	94081A
High Voltage Cable Assembly	82330-0006	94021A
High Voltage Cable Assembly	90020485	94041A, 94061A, 94081A
Shutter Assembly	8071-210	94021A
Shutter Assembly	91199	94041A, 94061A, 94081A
Solar Simulator Digital Exposure System	68951	94021A, 94041A, 94061A, 94081A
Remote Shutter Control	68955	94021A, 94041A, 94061A, 94081A
Ignitor Assembly	90020217	94021A
Ignitor Assembly	92514-1050	94041A, 94061A, 94081A
UV Protective Eyewear/Goggles	49125 , 49126, 49132	94021A, 94041A, 94061A, 94081A
Protective Gloves	49121 , 49123	94021A, 94041A, 94061A, 94081A

Table 8: Products and Accessories

To obtain these products and accessories, please contact NEWPORT.

For more information visit: <https://www.newport.com/b/oriel-instruments>.

10 APPENDIX A: DIMENSIONAL AND MOUNTING DIAGRAMS

NOTE: For figures 8 - 11, dimensions are listed in [millimeters] and inches.

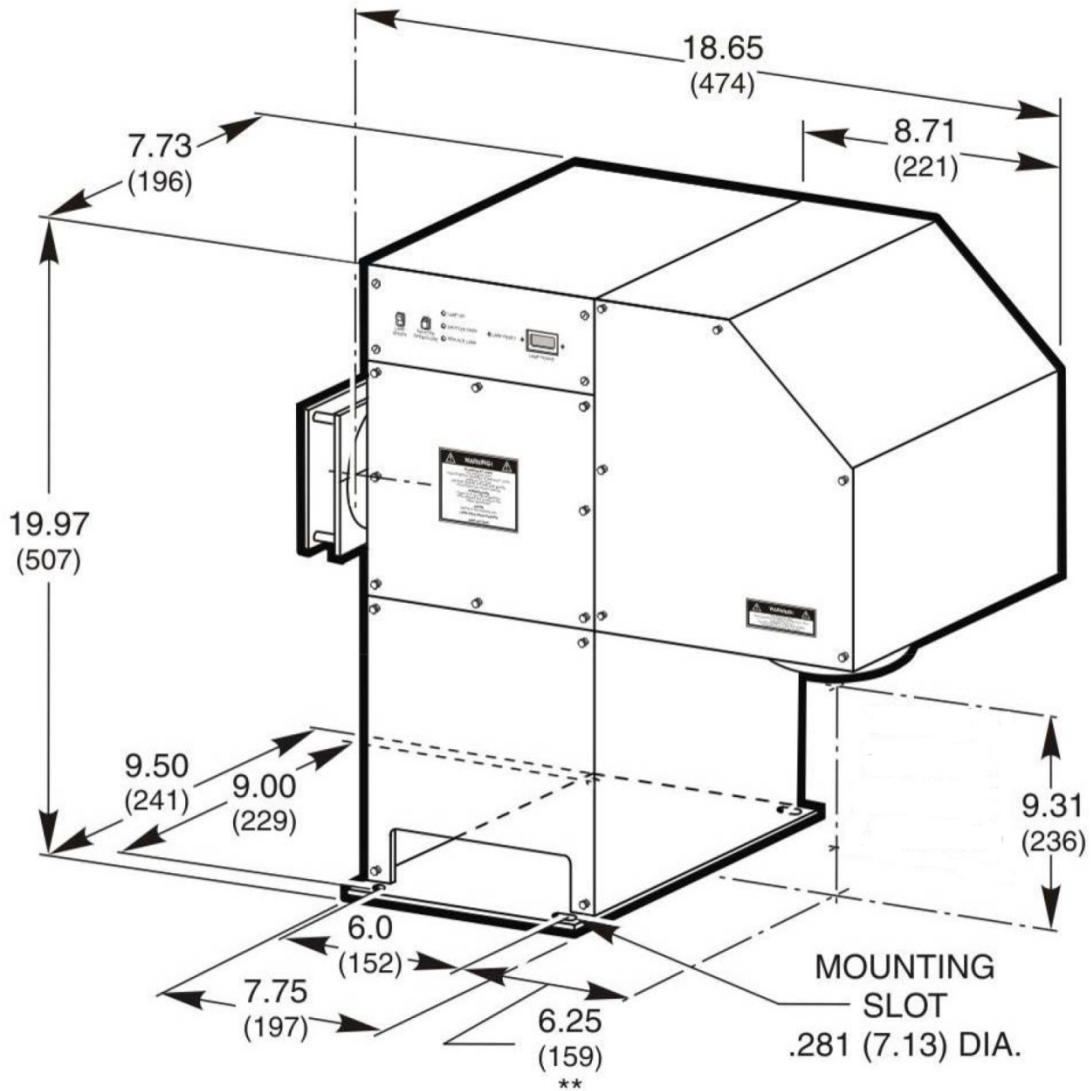

** THE DISTANCE FROM THE CENTER OF THE BEAM PATH TO THE CENTER OF THE MOUNTING HOLE.

Figure 8: 2x2 System (94021A)

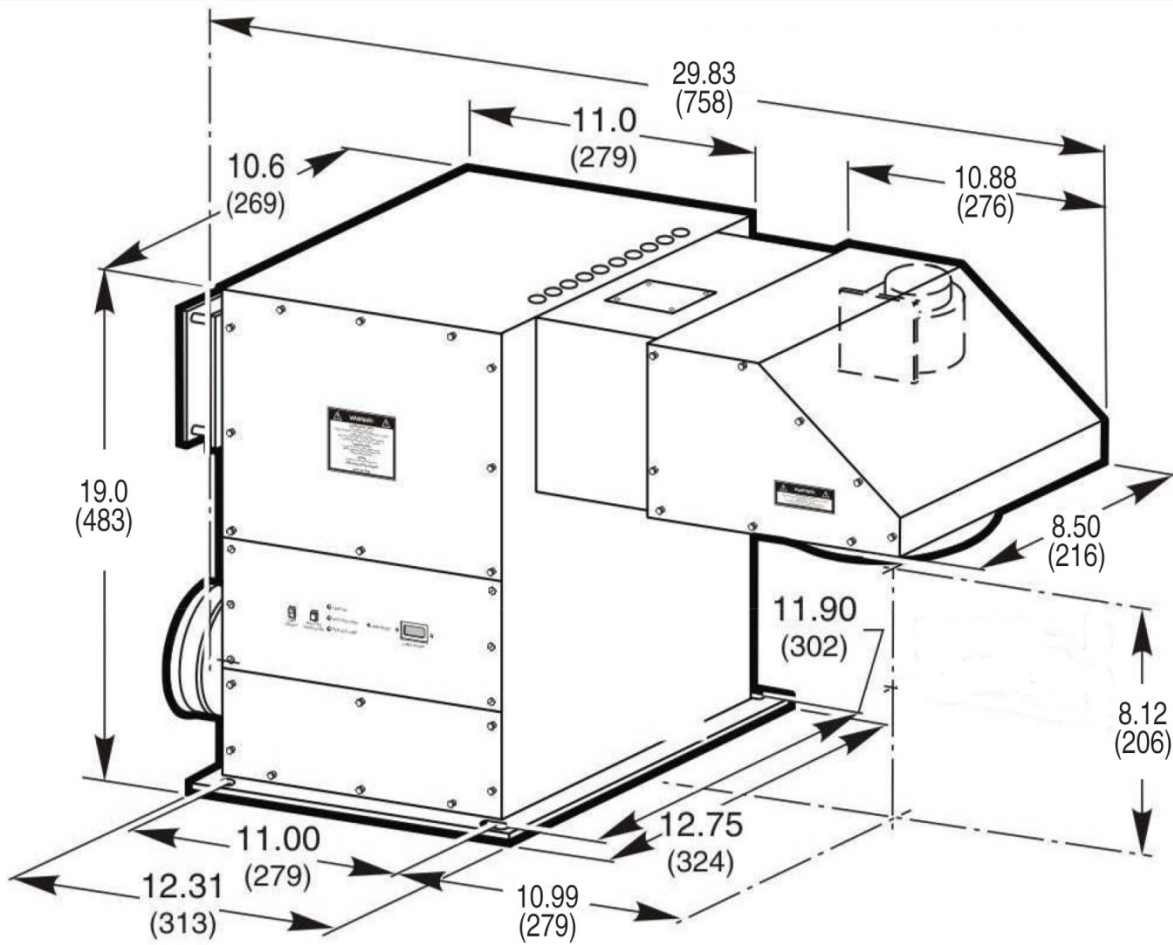
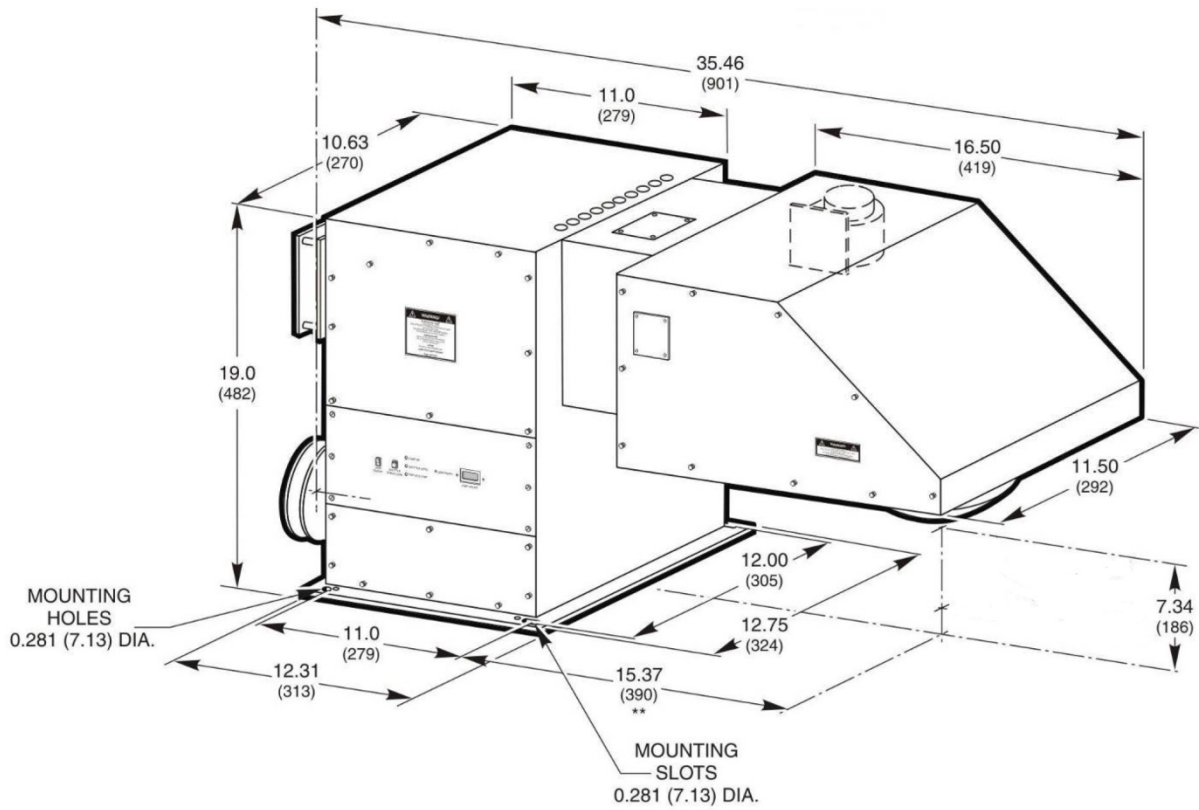

Figure 9: 4x4 System (94041A)



** THE DISTANCE FROM THE CENTER OF THE BEAM PATH TO THE CENTER OF THE MOUNTING HOLE.

Figure 10: 6x6 System (94061A)

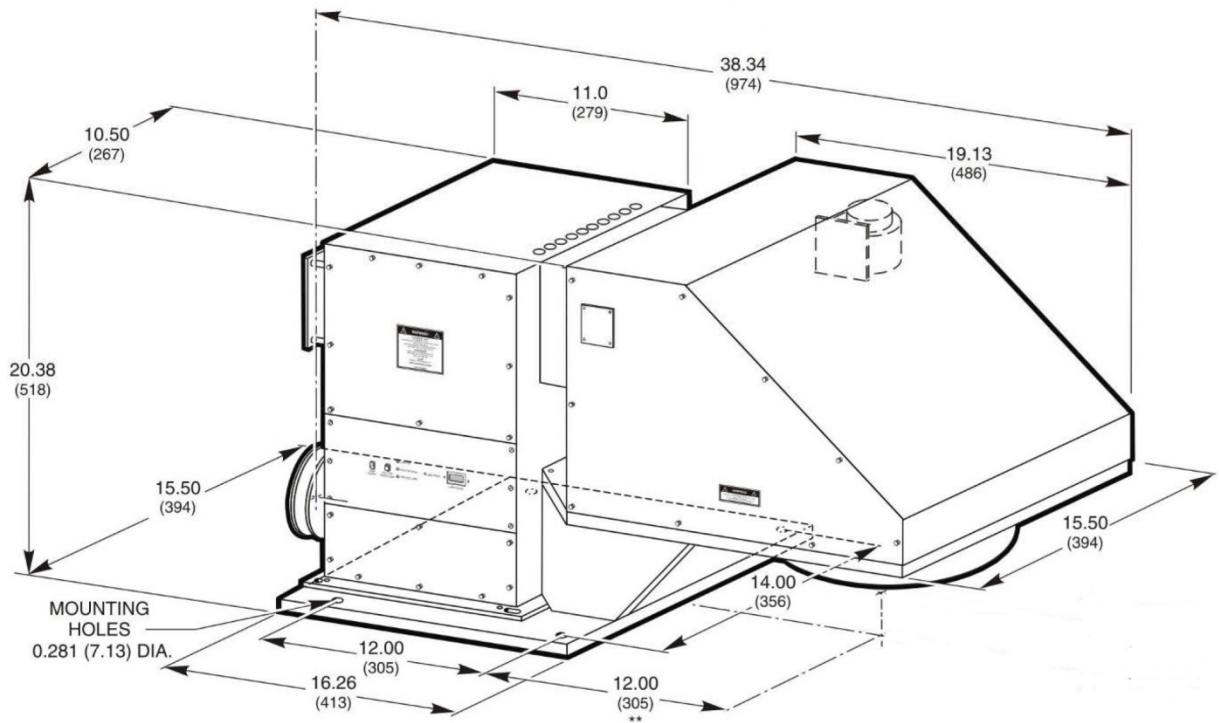

Figure 11: 8x8 System (94081A)

11 APPENDIX B: REPORTS AND CERTIFICATIONS

11.1 NON UNIFORMITY REPORT

Performance validation procedure of Non-uniformity of irradiance:

1. IEC and ASTM non-uniformity of irradiance of Sol1A Model 94021A, Serial# 1005, lamp serial# RCO677 is 2.44%

The IEC and ASTM uniformity measurement data consists of 64 data points, where the designated test area was divided into 64 equally sized (by area) test positions (blocks). The uniformity detector size was divided by 64. A single detector was used for measurements covering 100% of the designated area and measurement positions were distributed uniformly over the designated test area.

2. JIS non-uniformity of irradiance of Sol1A Model 94021A, Serial# 1005, lamp serial# RCO677 is 2.06%

The JIS uniformity measurement data consists of 17 data points as required and mapped in JIS standard for measuring positional non-uniformity of irradiance, where a single square detector was used with size not exceeding 2 cm and 4% of effective irradiated plane.

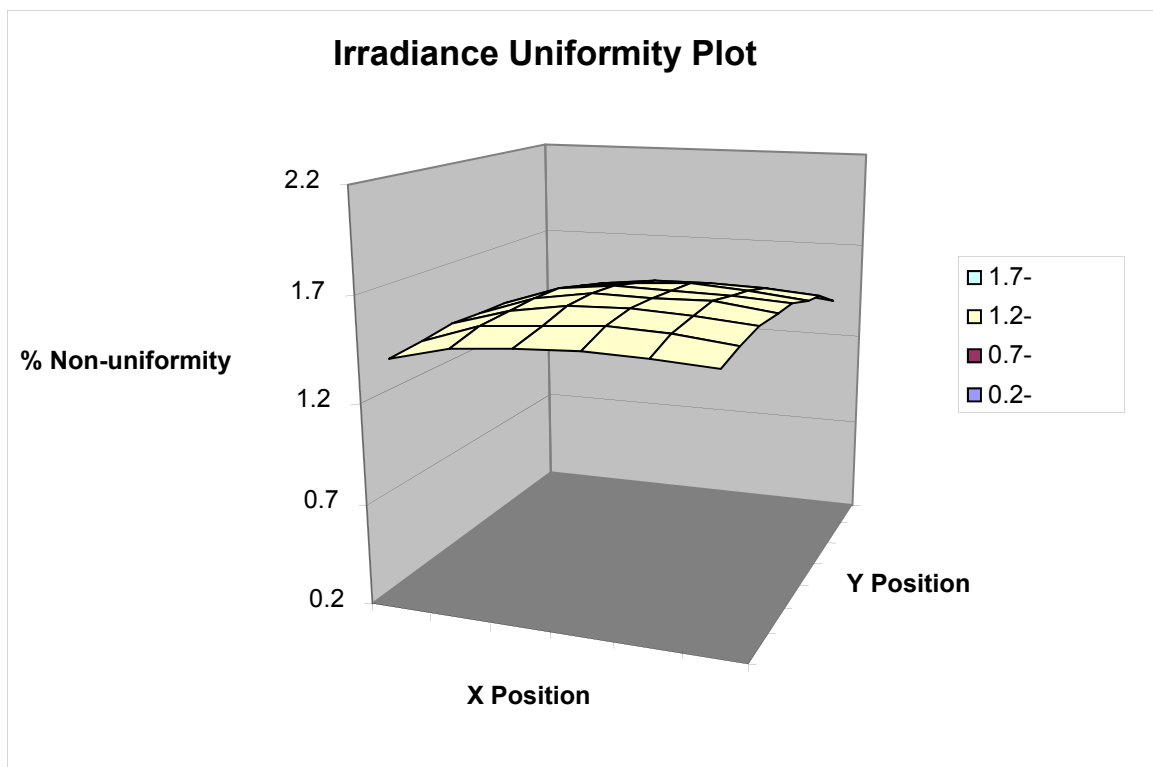

11.2 TEMPORAL INSTABILITY REPORT

Performance validation procedure of temporal instability of irradiance:

1. Temporal instability of irradiance of Sol1A Model 94021A, Serial# 1005, Lamp# RCC677

The temporal instability measurement data consists of 20 samples acquired over each time period in consideration. Data was acquired by placing a solar cell in the optical center of the lens at the model-specified height of reference plane where the measured irradiance was 1 SUN (+/- 0.05 SUN). Irradiance level was measured using a NREL-calibrated reference cell.

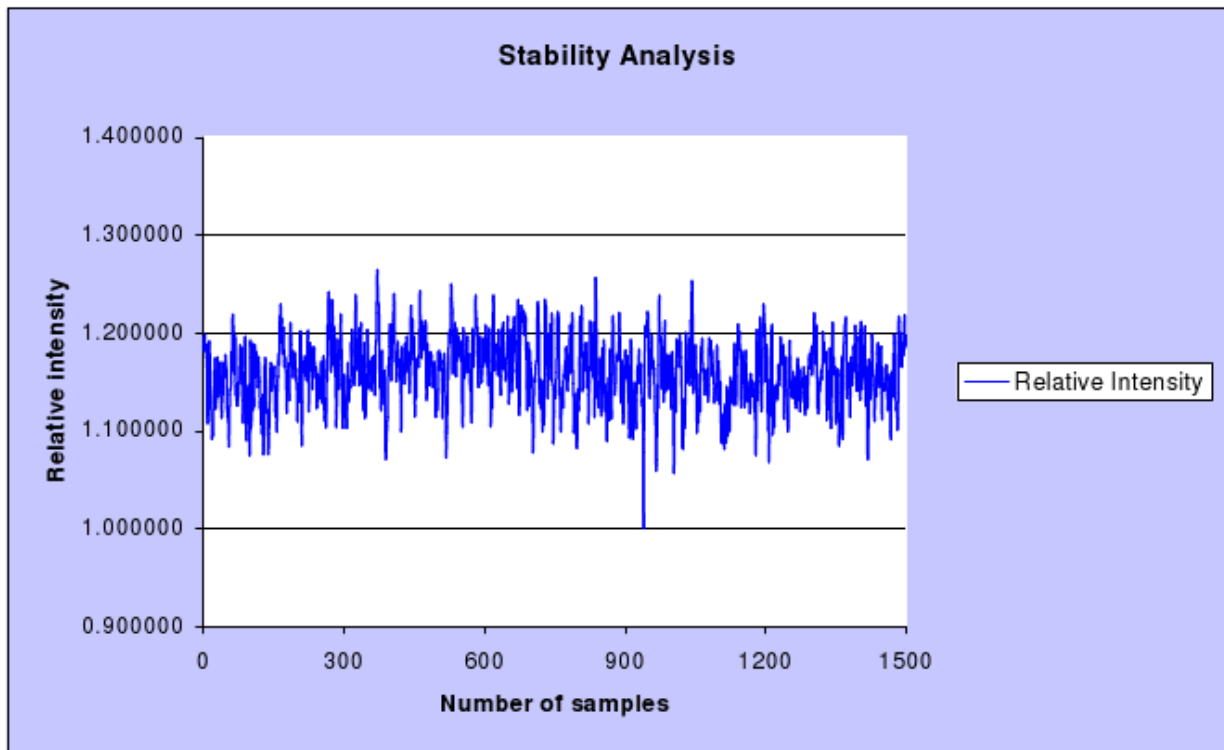

11.3 SPECTRAL MATCH REPORT

Performance validation of Spectral Match:

	400-500	500-600	600-700	700-800	800-900	900-1100	400-1100
Ideal Match%	18.40%	19.90%	18.40%	14.90%	12.50%	15.90%	100.00%
Upper Limit%	23.00%	24.88%	23.00%	18.63%	15.63%	19.88%	
Lower Limit%	13.80%	14.93%	13.80%	11.18%	9.38%	11.93%	
Sol1A%	21.69%	21.23%	18.88%	11.57%	12.32%	14.31%	

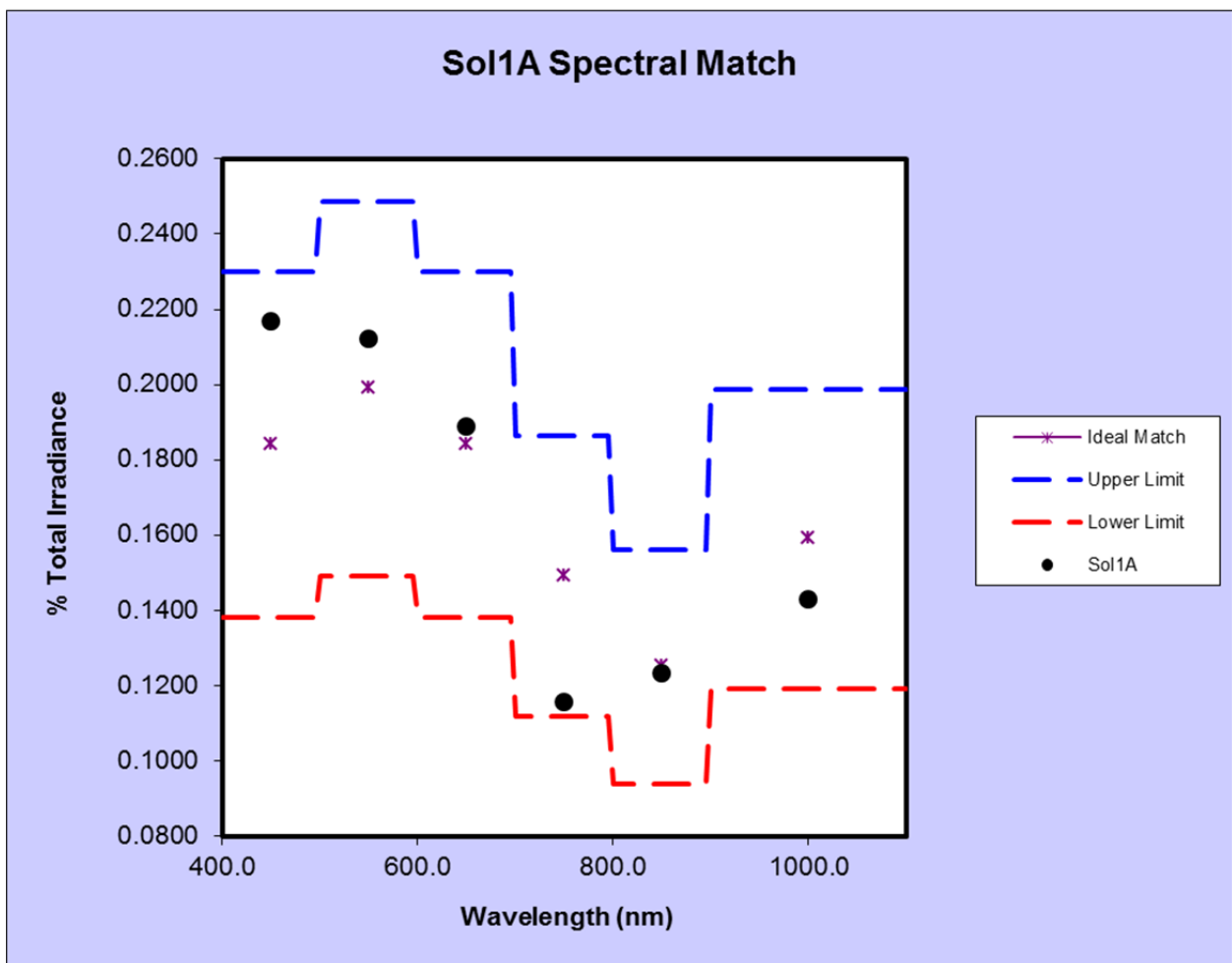

First printing 2010

© 2011 by Newport Corporation, Irvine, CA. All rights reserved.
No part of this manual may be reproduced or copied without the prior written approval of Newport Corporation.

This manual has been provided for information only and product specifications are subject to change without notice.
Any change will be reflected in future printings.

Newport Corporation 1791 Deere Avenue Irvine, CA, 92606 USA