

HIGH PRECISION MOTION SIMULATOR

RGV HIGH SPEED ROTATION STAGES

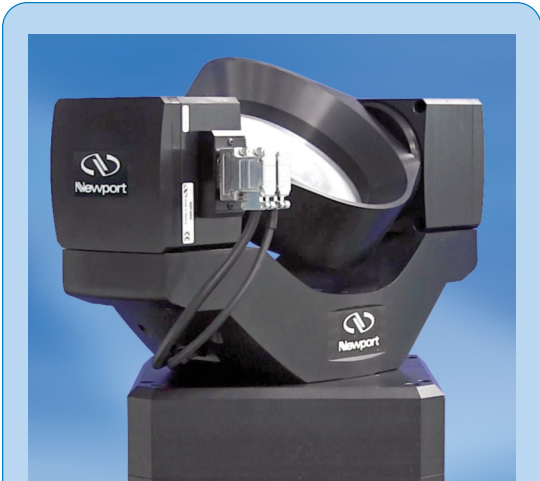

High speed 2-axis motion simulator using RGV series for MEMS-based inertial sensors testing.

- High Precision
- Robust
- Easy programming and control
- Configurable to your needs

Unit Under Test Capability

Mass	10 kg
Envelope	10" x Ø 10" (254 x Ø 254 mm)
Slip ring to UUT	Customer definable

Leveraging Newport's expertise in high-precision stages and motion control, we now offer motion simulators for the accurate calibration and testing of Inertial Guidance Sensors or MEMS devices, whether in a research setting or in a production environment.

Newport's standard Direct Drive Rotation stages are high dynamic performance rotation stages and are optimized to address high throughput needs. The design leverages over 50 years of expertise in supplying motion control equipment to various industries that demand high precision motion.

Complementing the robust rotary stages is the XPS Universal Controller, a powerful and feature-rich controller with integrated drivers, making it very easy to configure, use and program. Multiple digital and analog I/O's, triggers and synchronization make the XPS more than suitable in motion simulator applications.

Controller

- Integrated controller and driver for minimal setup
- Ethernet Communication Interface for remote monitoring of process
- TCL scripting for real time execution of programs
- Multiple Digital and Analog I/O's
- Interlock for safety

Options

- Slip rings
- Brakes

Call us for your Motion Simulator or Test and Calibration needs!

General Simulator Specifications

	Elevation	Azimuth
Travel Range (°)	Programmable Range or Continuous	
MIM (°)	0.0001	0.00004
Accuracy (°)	0.01	
Repeatability (°)	0.0004	0.0003
Max. Rate (°/s)	720	960
Max. Acceleration (°/s ²)	5000	7000



RGV100HL High-speed precision rotation stage.

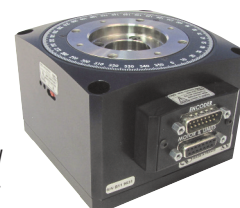

Dimensions

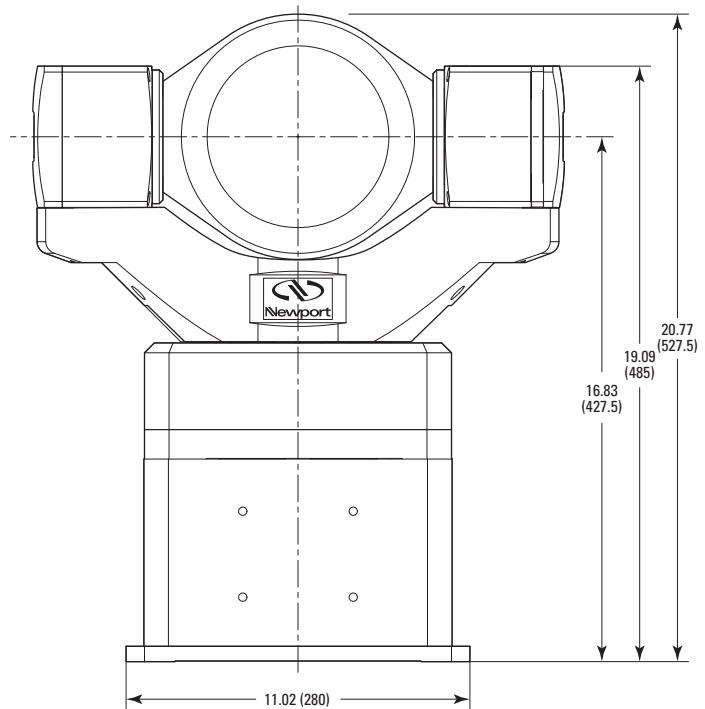
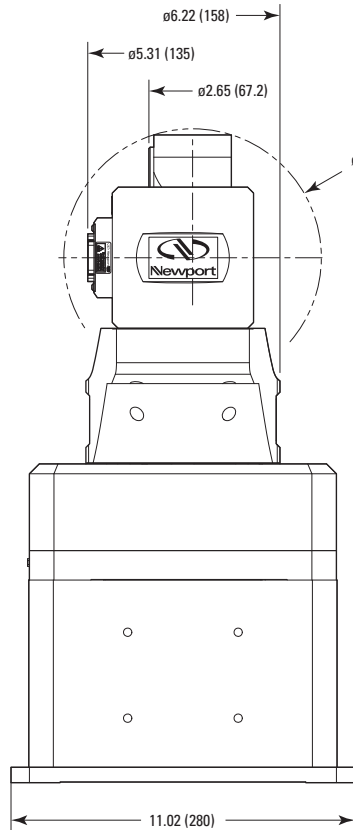
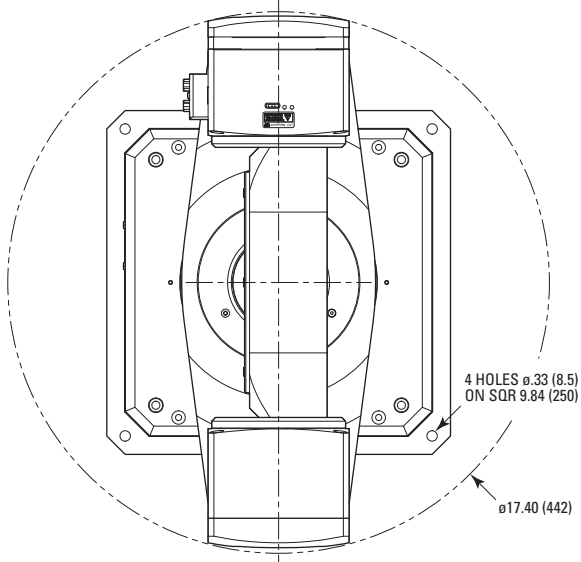

Newport Corporation, Global Headquarters
1791 Deere Avenue, Irvine, CA 92606, USA

PHONE: 1-800-222-6440 1-949-863-3144 FAX: 1-949-253-1680 EMAIL: sales@newport.com
Complete listings for all global office locations are available online at www.newport.com/contact

www.newport.com

	PHONE	EMAIL
Belgium	+32-(0)0800-11 257	belgium@newport.com
China	+86-10-6267-0065	china@newport.com
France	+33-(0)1-60-91-68-68	france@newport.com
Japan	+81-3-3794-5511	spectra-physics@splasers.co.jp
Taiwan	+886 -(0)2-2508-4977	sales@newport.com.tw

	PHONE	EMAIL
Irvine, CA, USA	+1-800-222-6440	sales@newport.com
Netherlands	+31-(0)30 6592111	netherlands@newport.com
United Kingdom	+44-1235-432-710	uk@newport.com
Germany / Austria / Switzerland	+49-(0)6151-708-0	germany@newport.com

Newport Corporation, Irvine, California and Franklin, Massachusetts; Evry and Beaune-La-Rolande, France and Wuxi, China have all been certified compliant with ISO 9001 by the British Standards Institution. Santa Clara, California is DNV certified.