

CONEX-AGAP

Agilis-D Controller with Strain Gages Feedback



Warranty

Newport Corporation warrants that this product will be free from defects in material and workmanship and will comply with Newport's published specifications at the time of sale for a period of one year from date of shipment. If found to be defective during the warranty period, the product will either be repaired or replaced at Newport's option.

To exercise this warranty, write or call your local Newport office or representative, or contact Newport headquarters in Irvine, California. You will be given prompt assistance and return instructions. Send the product, freight prepaid, to the indicated service facility. Repairs will be made and the instrument returned freight prepaid. Repaired products are warranted for the remainder of the original warranty period or 90 days, whichever occurs last.

Limitation of Warranty

The above warranties do not apply to products which have been repaired or modified without Newport's written approval, or products subjected to unusual physical, thermal or electrical stress, improper installation, misuse, abuse, accident or negligence in use, storage, transportation or handling.

THIS WARRANTY IS IN LIEU OF ALL OTHER WARRANTIES, EXPRESSED OR IMPLIED, INCLUDING ANY IMPLIED WARRANTY OF MERCHANTABILITY OR FITNESS FOR A PARTICULAR USE. NEWPORT CORPORATION SHALL NOT BE LIABLE FOR ANY INDIRECT, SPECIAL, OR CONSEQUENTIAL DAMAGES RESULTING FROM THE PURCHASE OR USE OF ITS PRODUCTS.

©2019 by Newport Corporation, Irvine, CA. All rights reserved.

Original instructions.

No part of this document may be reproduced or copied without the prior written approval of Newport Corporation. This document is provided for information only, and product specifications are subject to change without notice. Any change will be reflected in future publishings.

Table of Contents

Warranty	ii
<hr/>	
1.0 System Overview.....	1
1.1 General Description	1
1.2 Part Numbers	1
1.2.1 CONEX-AGAP.....	1
1.2.2 Accessories.....	1
1.3 CONEX-AGAP.....	2
1.3.1 Delivered Items	2
1.3.2 Specifications	2
1.3.3 Dimensions.....	3
1.4 System Environmental Specifications.....	3
1.5 Connector Identification	3
1.6 USB Communication Settings	4
<hr/>	
2.0 Programming	5
2.1 State Diagram.....	5
2.2 Command Syntax.....	7
2.3 Command Execution Time	7
2.4 Command Set.....	7
DB[a] — Set/Get corrector deadband	9
DD[a] — Set/Get deadband settling time	10
ID — Set/Get stage identifier.....	11
JA _[a] — Jog motion	12
KI[a] — Set/Get integral gain.....	13
KP[a] — Set/Get proportional gain.....	14
KY[a] — Set/Get calibration coefficients.....	15
KZ[a] — Set/Get calibration coefficients	16
LF — Set/Get low pass filter frequency.....	17
MM — Enter/Leave DISABLE state	18
PA _[a] — Move absolute	19
PR _[a] — Move relative.....	20
PW — Enter/Leave CONFIGURATION state	21
RS — Reset controller	22
RS## — Reset controller's address.....	23
SA — Set/Get controller's RS-485 address	24
SL _[a] — Set/Get negative software limit	25
SR _[a] — Set/Get positive software limit	26

ST — Stop motion	27
SU — Set/Get system resolution.....	28
TB — Get command error string	29
TE — Get last command error	30
TH _[a] — Get target position.....	31
TP _[a] — Get current position	32
TS — Get positioner error and controller state	33
VE — Get controller revision information	35
XR _[a] — Step motion.....	36
XU _[a] — Set/Get step motion size	37
ZT — Get all configuration parameters	38
<hr/>	
3.0 Connector interfaces.....	39
3.1 USB (Male mini-USB).....	39
<hr/>	
Service Form	41



Agilis-D Controller with Strain Gages Feedback

CONEX-AGAP

1.0 System Overview

1.1 General Description

The CONEX-AGAP is a two-axis motion controller/driver for piezo actuator with Strain Gages Feedback. It provides a very compact and low-cost solution for driving a variety of Newport Agilis-type piezo stages from a PC.

Communication with the CONEX-AGAP is achieved via an USB port (requires Windows™ operating system). A Windows™ based software enables basic motion. Advanced application programming is simplified by an ASCII command interface and a set of three-letter mnemonic commands.

1.2 Part Numbers

1.2.1 CONEX-AGAP

Product	Description
CONEX-AG-M100-D	CONEX-AGAP controller with mirror mount.

1.2.2 Accessories

CONEX-USB	USB cable, 1.8 m length
CONEX-BP	Base plate to attach up to 6 CONEX controllers

1.3 CONEX-AGAP

1.3.1 Delivered Items

- CONEX-AG-M100D Controller box with stage (cable length: 1 m)
- CONEX-USB USB cable, 1.8 m length
- CONEX-MOTION CD-Rom



1.3.2 Specifications

General Description	Agilis controller with strain gages feedback
Control Capability	Piezo motors, open or closed loop
Piezo Output Voltage	35 V _{peak}
Control loop	– Digital PI loop – 50 Hz servo rate
Motion	Absolute and relative motion in open or closed loop
Computer interface	– USB (requires Windows™ operating system)
Programming	– 25+ intuitive, 2- or 3-letter ASCII commands – Command set includes software limits...
Dedicated inputs	– Analog signals from gages
Status display	Two color LED
Communication rate	50 Hz Max. (USB)
Internal safety feature	Watchdog timer
Consumption +5V (USB):	<0.5 A

1.3.3 Dimensions

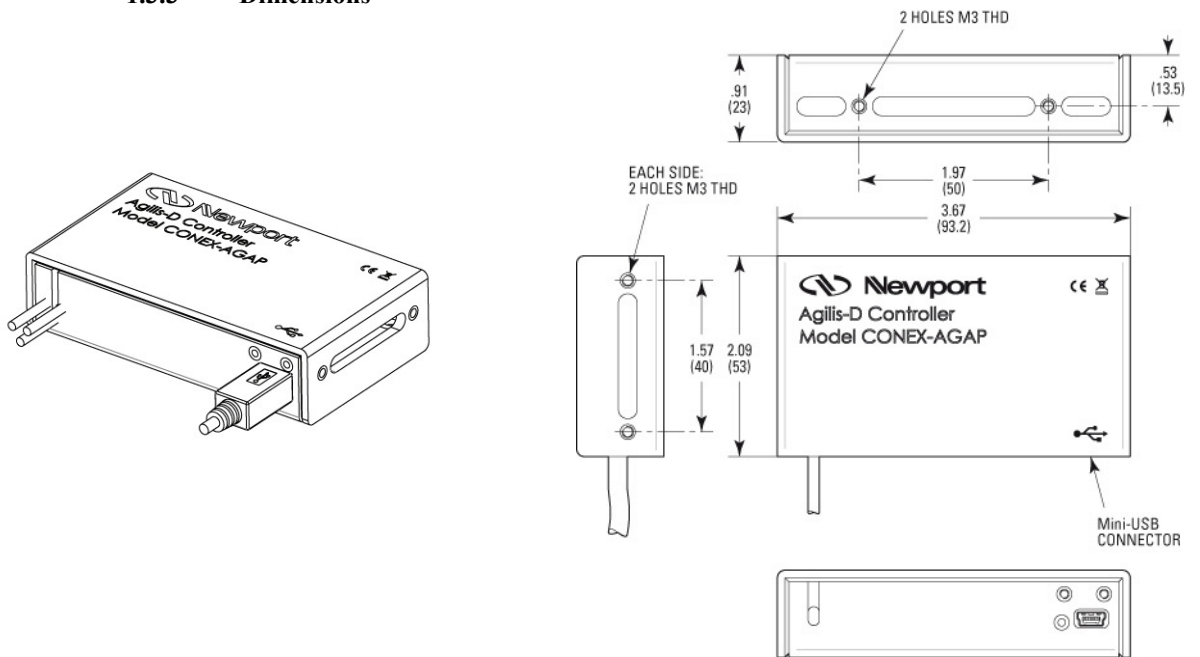

1.4 System Environmental Specifications

Operating temperature	15 °C to 35 °C
Operating humidity	20% to 85% relative humidity, non-condensing
Location	Indoor use only

1.5 Connector Identification

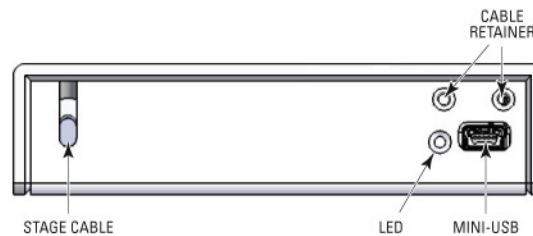

USB	mini USB connector
LED	Status LED
STAGE	Stage entry cable
Cable retainer	2 x M3 threaded hole to attach cable retainer

1.6 USB Communication Settings

Communication parameters are preset in the CONEX-AGAP controller and do not require any configuration:

Bits per second	921,600
Data bits	8
Parity	None
Stop bits	1
Flow control	Xon/Xoff
Terminator	C _R L _F

2.0 Programming

2.1 State Diagram

For a safe and consistent operation, the CONEX-AGAP uses 6 different operational states: Configuration, Ready OL, Disable and Moving CL., Stepping OL and Jogging OL. In each state, only specific commands are accepted by the CONEX-AGAP. Therefore, it is important to understand the state diagram below and which commands and actions cause transitions between the different states. See section 2.4 for additional command/state information:

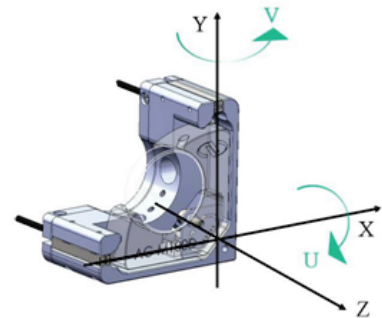
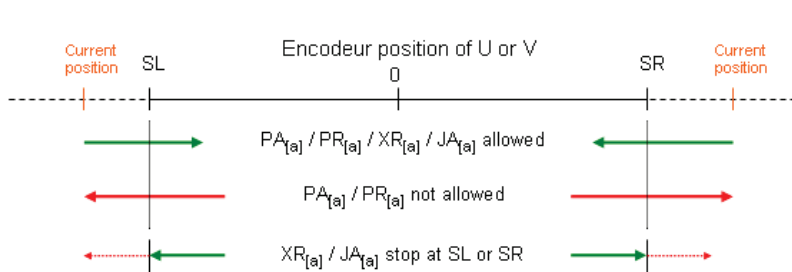
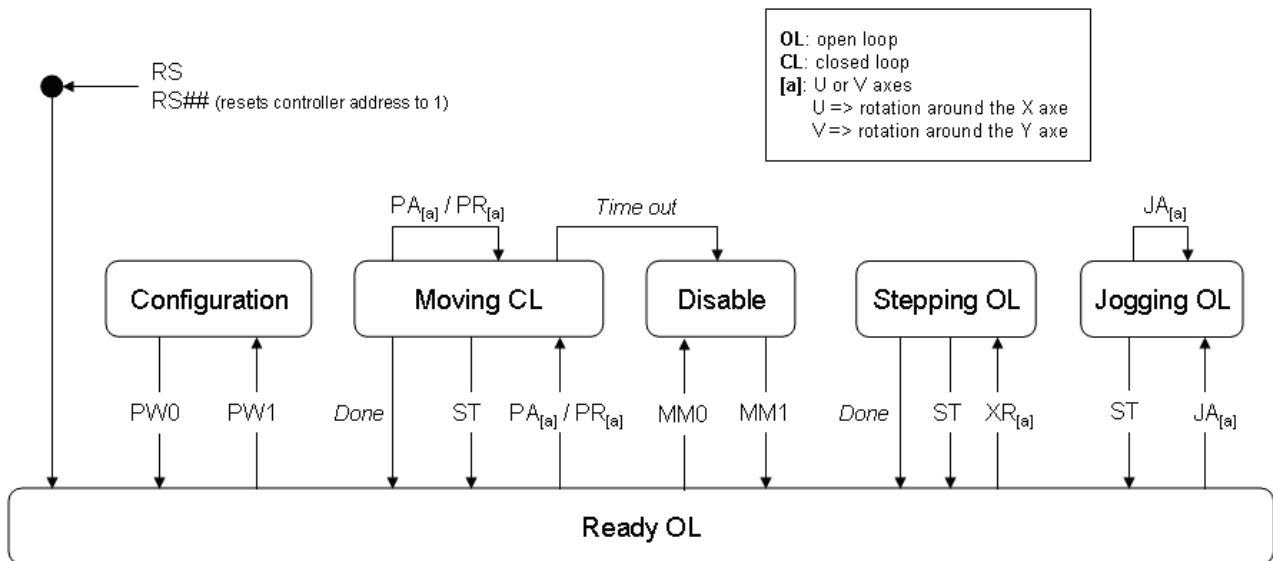

LED display:

- CONFIGURATION: SLOW BLINKING RED.
- READY OL: SOLID GREEN.
- DISABLE: SLOW BLINKING GREEN.
- MOVING CL: FAST BLINKING GREEN.
- STEPPING OL: FAST BLINKING GREEN.
- JOGGING OL: FAST BLINKING GREEN.

When powering the CONEX-AGAP, the controller starts initialization. When the initialization is successful, the controller goes to the READY OL state. The controller can go to the CONFIGURATION state using the PW1 command. In the CONFIGURATION state, the CONEX-AGAP allows changes to all configuration parameters, like travel limits or controller address. The PW0 command saves all changes to the controller's memory and returns the controller back to the DISABLE states.

To execute move commands PA[a], PR[a], the controller must be in the READY OL or MOVING CL states. To get from the DISABLE state to the READY OL state, the positioner must be enabled first with the MM1 command.

In the READY OL state, the control loop is open. During a move execution (PA/PR), the loop is closed, the controller is in the MOVING CL state and goes automatically back to the READY OL state when the move is completed. A time out error during a move changes the controller to the DISABLE state.

In the DISABLE state, the control loop is open. But the encoder is still read and the current position gets updated. To go from the READY state to the DISABLE state and vice versa, use the MM command. Going to DISABLE state is allowed for compatibility with other Newport products.

2.2 Command Syntax

The CONEX-AGAP is a command driven controller. The general format of a command is a two-letter ASCII character preceded and followed by parameters specific to the command:

Command format:

nn	AA	xx
-----------	-----------	-----------

nn — Optional or required controller address.

AA — Command name.

xx — Optional or required value or “?” to query current value.

Both, upper and lower case characters are accepted. Depending on the command, it can have an optional or required prefix (**nn**) for the controller address and/or a suffix (**xx**) value or a “?”.

Blank spaces

Blanks are allowed and ignored in any position, including inside a numerical value. The following two commands are equivalent, but the first example might be confusing and uses more memory:

2P A1.43 6

2PA1.436

Decimal separator

A dot (“.”) is used as decimal separator for all numerical values.

Command terminator

Commands are executed as the command terminator $C_{R}L_{F}$ (carriage-return line-feed, ASCII 13 and ASCII 10) is received. The controller will analyze the received string. If the command is valid and its parameters are in the specified range, it will be executed. Otherwise it will memorize an error.

After the execution of the command, all remaining characters in the input string, if any, will be ignored. In particular, it is not possible to concatenate several commands on a single string from the PC to the CONEX-AGAP

Each command will handle the memorization of related errors that can be accessed with the TE command properly. Please refer to the command set in section 2.4 for details.

2.3 Command Execution Time

The CONEX-AGAP controller interprets commands continuously as received. The typical execution time for a "tell position command" (nTP?) is about 10 ms. Here, command execution time means the time from sending the command until receipt of the answer.

It is important to note that a move command that may last for several seconds will not suspend the controller from further command execution. For an efficient process flow with many move commands, it is recommended to query the controller status (TS command) or the current position (TP command) before any further motion command is sent.

2.4 Command Set

This section describes the supported two-letter ASCII commands used to configure and operate the CONEX-AGAP. The general command format is:

Command format:

nn	AA	a	xx
----	----	---	----

nn — Optional or required controller address.

AA — Command name.

a — Optional axis reference (U or V)

xx — Optional or required value or “?” to query current value.

Most commands can be used to set a value (in that case the command name is followed by the value “xx”) or to query the current value (in that case the command name is followed by a “?”). When querying a value, the controller responds with the command it received followed by the queried value.

Not every command can be executed in all states of the CONEX-AGAP and some commands have different meanings in different states. It is therefore important to understand the state diagram of the controller, see section 2.1.

	Config.	Disable	Ready	Moving	Stepping	Jogging	Description
DB[a]	○	□	□	–	–	–	Set/Get corrector deadband
DD[a]	○	□	□	–	–	–	Set/Get deadband settling time
ID	○	□	□	–	–	–	Set/Get stage identifier
JA[a]	–	–	●	–	–	●	Move jogging
KI[a]	○	□	□	–	–	–	Set/Get integral gain
KP[a]	○	□	□	–	–	–	Set/Get proportional gain
KY	○	–	–	–	–	–	Set/Get calibration coefficients
KZ	○	–	–	–	–	–	Set/Get calibration coefficients
LF	○	□	□	–	–	–	Set/Get low pass filter frequency
MM	–	●	●	–	–	–	Leave DISABLE state
PA[a]	–	–	●	●	–	–	Move absolute
PR[a]	–	–	●	●	–	–	Move relative
PW	●	–	●	–	–	–	Enter/Leave CONFIGURATION state
RS	●	●	●	●	●	●	Reset controller
RS##	●	●	●	●	●	●	Reset controller’s address to 1
SA	○	–	–	–	–	–	Set/Get controller’s RS-485 address
SL[a]	○	□	□	–	–	–	Set/Get negative software limit
SR[a]	○	□	□	–	–	–	Set/Get positive software limit
ST[a]	–	–	–	●	●	●	Stop motion
SU	○	□	□	–	–	–	Set/Get encoder resolution
TB	●	●	●	●	●	●	Get command error string
TE	●	●	●	●	●	●	Get last command error
TH[a]	●	●	●	●	–	–	Get target position
TP[a]	●	●	●	●	●	●	Get current position
TS	●	●	●	●	●	●	Get positioner error and controller state
VE	●	●	●	●	●	●	Get controller revision information
XR[a]	–	–	●	–	–	–	Move stepping
XU[a]	□	□	□	–	–	–	Set/Get step size for STEPPING OL state
ZT	●	●	●	–	–	–	Get all controller parameters

- Changes configuration parameters. Those changes will be stored in the controller’s memory with the PW1 command and remain available after switching off the controller.
- Changes working parameters only. Those changes will get lost when switching off the controller.
- Accepted command.
- Write command not accepted (will return an error).

Command: Command passed without preceding controller number applies to all controllers (e.g. ST stops all controllers).

DB[a] — Set/Get corrector deadband

Usage	Config.	Disable	Ready OL	Moving CL	Stepping OL	Jogging OL
	○	□	□	-	-	-
Syntax	xxDB[a]nn or xxDB[a]?					
Parameters						
Description	xx [int]	—	Controller address.			
	a [char]	—	Axe reference.			
	nn [int]	—	Deadband value.			
Range	xx	—	1 to 31			
	a	—	U or V			
	nn	—	0 to 0.005			
Units	xx	—	None.			
	nn	—	Deg.			
Defaults	xx Missing:	Error B.				
	Out of range:	Error B.				
	Floating point:	Error A.				
Description	The deadband parameter defines an area, around a set position, in which the controller will consider it is the end of the closed loop motion.					
Errors	A	—	Unknown message code or floating point controller address.			
	B	—	Controller address not correct.			
	D	—	Execution not allowed.			
	V	—	Unknown axe reference.			
Rel. Commands	DD[a]	—	Set/Get deadband settling time.			
Example	1DB0.00075		<i>Set controller #1 deadband to 0.75 mdeg.</i>			

DD[a] — Set/Get deadband settling time

Usage	Config.	Disable	Ready OL	Moving CL	Stepping OL	Jogging OL
	○	□	□	-	-	-
Syntax	xxDD[a]nn or xxDD[a]?					
Parameters						
Description	xx [int]	—	Controller address.			
	a [char]	—	Axe reference.			
	nn [int]	—	Timer value.			
Range	xx	—	1 to 31			
	a	—	U or V			
	nn	—	0 to 10⁴			
Units	xx	—	None.			
Defaults	xx	Missing:	Error B.			
		Out of range:	Error B.			
		Floating point:	Error A.			
Description	This command sets the deadband settling time. It corresponds to the number of corrector cycle after which, when the current position is below the deadband value from the target position, the system considers it has reached the target position.					
Errors	A	—	Unknown message code or floating point controller address.			
	B	—	Controller address not correct.			
	D	—	Execution not allowed.			
	V	—	Unknown axe reference.			
Rel. Commands	DB[a]	—	Set/Get corrector deadband.			
Example	1DD10		<i>Set controller #1 timer to 10 control loop period.</i>			

ID — Set/Get stage identifier

Usage	Config.	Disable	Ready OL	Moving CL	Stepping OL	Jogging OL
	○	□	□	-	-	-
Syntax	xxIDnn or xxID?					
Parameters						
Description	xx [int]	—	Controller address.			
	nn [char]	—	Stage model number.			
Range	xx	—	1 to 31			
	nn	—	1 to 31 ASCII characters.			
Units	xx	—	None			
	nn	—	None			
Defaults	xx Missing:		Error B.			
	Out of range:		Error B.			
	Floating point:		Error A.			
	nn Missing:		Error C.			
	Out of range:		Error C.			
Description	The ID? command returns the product name. In CONFIGURATION mode, this command allows changing the controller identifier.					
Returns	If the sign “?” takes place of nn , this command returns the current programmed value.					
Errors	A	—	Unknown message code or floating point controller address.			
	B	—	Controller address not correct.			
	C	—	Parameter missing or out of range.			
	D	—	Execution not allowed.			
Rel. Commands	ZT	—	Get configuration parameters.			
Example	<code>IID?</code>		<i>Get stage identifier for controller #1.</i>			
	<code>IID CONEX-AGAP</code>		<i>Controller returns product name: CONEX-AGAP.</i>			

JA_[a] — Jog motion

	Usage	Config.	Disable	Ready OL	Moving CL	Stepping OL	Jogging OL
		—	—	●	—	—	●
Syntax	xxJA[a]nn or xxJA[a]?						
Parameters							
Description	xx [int]	—	Controller address.				
	a [char]	—	Axe reference.				
	nn [float]	—	Percentage of full speed.				
Range	xx	—	1 to 31				
	a	—	U or V				
	nn	—	-100 to 100				
Units	xx	—	None.				
	nn	—	% Full speed.				
Defaults	xx Missing:	Error B.					
	Out of range:	Error B.					
	Floating point:	Error A.					
Description	If in READY state, the JA command sets the controller in JOGGING state, and make a relative motion with a speed, i.e.: a set of pulse amplitude and frequency, which follows a law between 0 and 100% as shown on the figure below.						
	Both axes can be in jog motion at the same time with different speed values. A speed of 0 stops the motion but does not take the controller out of the JOGGING state. The use of ST command returns to the controller to READY state.						
Errors	A	—	Unknown message code or floating point controller address.				
	B	—	Controller address not correct.				
	I	—	Execution not allowed in CONFIGURATION state.				
	J	—	Execution not allowed in DISABLED state.				
	M	—	Execution not allowed in Motion states.				
	V	—	Unknown axe reference.				
Rel. Commands	TP[a]	—	Get current position				
	ST	—	Stop motion				
Example	1JAU50.35		Set controller #1 speed at 50.35% of full speed on axe U.				

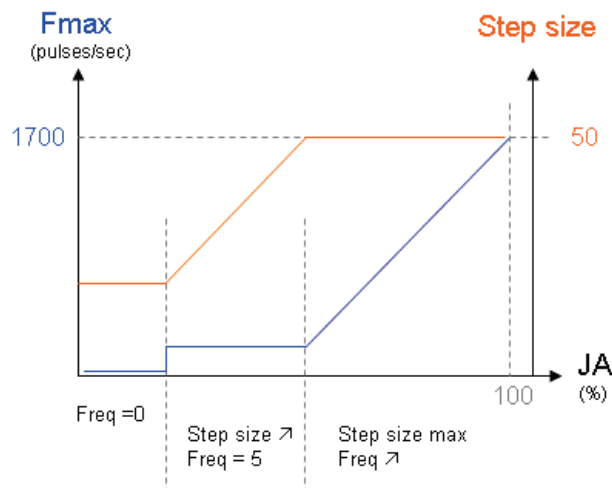

NOTE
Not to scale.

KI[a] — Set/Get integral gain

Usage	Config.	Disable	Ready OL	Moving CL	Stepping OL	Jogging OL
	○	□	□	—	—	—
Syntax	xxKI[a]nn or xxKI[a]?					
Parameters						
Description	xx [int]	—	Controller address.			
	a [char]	—	Axe reference.			
	nn [int]	—	Integral gain.			
Range	xx	—	0 to 31			
	a	—	U or V			
	nn	—	>0.			
Units	xx	—	None.			
	nn	—	None.			
Defaults	xx	Missing:	Change to 0.			
		Out of range:	Error B.			
		Floating point:	Error A.			
	nn	Missing:	Error C.			
		Out of range:	Error C.			
Description	<p>In CONFIGURATION state, this command sets the integral gain of the PID control loop which can then be saved in the controller’s nonvolatile memory using the PW command. It is also the default value that will be used unless a different value is set in DISABLE state.</p> <p>In DISABLE state, this command allows setting a new working parameter for the derivative gain. This value is not saved in the controller’s memory and will be lost after reboot.</p>					
Returns	If the sign “?” takes place of nn, this command returns the current programmed value.					
Errors	A	—	Unknown message code or floating point controller address.			
	B	—	Controller address not correct.			
	C	—	Parameter missing or out of range.			
	D	—	Execution not allowed.			
	M	—	Execution not allowed in Motion states.			
	V	—	Unknown axe reference.			
Rel. Commands	KP	—	Set/Get proportional gain.			
	LF	—	Set/Get low pass filter frequency.			
Example	1KIU5		<i>Set the controller #1U axe integral gain to 5</i>			
	1KIU?					
			<i>1KIU5</i>			

KP[a] — Set/Get proportional gain

Usage	Config.	Disable	Ready OL	Moving CL	Stepping OL	Jogging OL
	○	□	□	-	-	-
Syntax	xxKP[a]nn or xxKP[a]?					
Parameters						
Description	xx [int]	—	Controller address.			
	a [char]	—	Axe reference.			
	nn [float]	—	Proportional gain.			
Range	xx	—	1 to 31			
	a	—	U or V			
	nn	—	>0			
Units	xx	—	None.			
	nn	—	Preset units.			
Defaults	xx	Missing:	Error B.			
		Out of range:	Error B.			
		Floating point:	Error A.			
	nn	Missing:	Error C.			
		Out of range:	Error C.			
Description	<p>In CONFIGURATION state, this command sets the proportional gain of the PID control loop which can then be saved in the controller's nonvolatile memory using the PW command. It is also the default value that will be used unless a different value is set in DISABLE state.</p> <p>In DISABLE state, this command allows setting a new working parameter for the derivative gain. This value is not saved in the controller's memory and will be lost after reboot.</p>					
Returns	If the sign "?" takes place of nn, this command returns the current programmed value.					
Errors	A	—	Unknown message code or floating point controller address.			
	B	—	Controller address not correct.			
	C	—	Parameter missing or out of range.			
	D	—	Execution not allowed.			
	M	—	Execution not allowed in Motion states.			
	V	—	Unknown axe reference.			
Rel. Commands	KI	—	Set/Get integral gain.			
	LF	—	Set/Get low pass filter frequency.			
Example	1KPU5		Set the controller #IU axe proportional gain to 5			
	1KPU?					
			<i>1KPU5</i>			

KY[a] — Set/Get calibration coefficients

Usage	Config.	Disable	Ready OL	Moving CL	Stepping OL	Jogging OL
	○	—	—	—	—	—
Syntax	xxKY[a]nn or xx KY?					
Parameters						
Description	xx [int]	—	Controller address.			
	a [char]	—	Coefficient reference.			
	nn [float]	—	Calibration value.			
Range	xx	—	1 to 31			
	a [char]	—	F or T or C			
Units	xx	—	None.			
	nn	—	Preset units.			
Defaults	xx	Missing:	Error B.			
		Out of range:	Error B.			
		Floating point:	Error A.			
	nn	Missing:	Error C.			
		Out of range:	Error C.			
Description	The KY command is used to set the calibration coefficients. Those are factory set values. Users should not modify those parameters.					
Returns	If the sign “?” takes place of nn , this command returns the calibration values.					
Errors	A	—	Unknown message code or floating point controller address.			
	B	—	Controller address not correct.			
	C	—	Parameter missing or out of range.			
	D	—	Execution not allowed.			

KZ[a] — Set/Get calibration coefficients

Usage	Config.	Disable	Ready OL	Moving CL	Stepping OL	Jogging OL
	○	—	—	—	—	—
Syntax	xxKZ[a]nn or xxKZ?					
Parameters						
Description	xx [int]	—	Controller address.			
	a [char]	—	Coefficient reference.			
	nn [float]	—	Calibration value.			
Range	xx	—	1 to 31			
	a [char]	—	F or T or C.			
Units	xx	—	None.			
	nn	—	None.			
Defaults	xx	Missing:	Error B.			
		Out of range:	Error B.			
		Floating point:	Error A.			
	nn	Missing:	Error C.			
		Out of range:	Error C.			
Description	The KZ command is used to set the calibration coefficients. Those are factory set values. Users should not modify those parameters.					
Returns	If the sign “?” takes place of nn, this command returns the calibration values.					
Errors	A	—	Unknown message code or floating point controller address.			
	B	—	Controller address not correct.			
	C	—	Parameter missing or out of range.			
	D	—	Execution not allowed.			
	J	—	Execution not allowed in DISABLE state.			
	M	—	Execution not allowed in Motion states.			

LF — Set/Get low pass filter frequency

Usage	Config.	Disable	Ready OL	Moving CL	Stepping OL	Jogging OL
	○	□	□	-	-	-
Syntax	xxLFnn or LF?					
Parameters						
Description	xx [int]	—	Controller address.			
	nn [float]	—	Frequency.			
Range	xx	—	1 to 31			
	nn	—	>0			
Units	xx	—	None.			
	nn	—	Hertz.			
Defaults	xx Missing:	Error B.				
	Out of range:	Error B.				
	Floating point:	Error A.				
Description	The LF command sets or gets the digital low pass filter frequency.					
Returns	If the sign “?” takes place of nn , this command returns the current programmed value.					
Errors	A	—	Unknown message code or floating point controller address.			
	B	—	Controller address not correct.			
	D	—	Execution not allowed.			
Rel. Commands	KP[a]	—	Set/Get proportional gain.			
	KI[a]	—	Set/Get integral gain.			
Example	1LF5		Set the <i>controller #1 low pass filter frequency to 5 Hz.</i>			

MM — Enter/Leave DISABLE state

Usage	Config.	Disable	Ready OL	Moving CL	Stepping OL	Jogging OL
	—	●	●	—	—	—
Syntax	xxMMnn or xxMM?					
Parameters						
Description	xx [int]	—	Controller address.			
	nn [int]	—	State change direction.			
Range	xx	—	0 to 31			
	nn	—	0 changes state from READY to DISABLE. 1 changes state from DISABLE to READY.			
Units	xx	—	None.			
	nn	—	None.			
Defaults	xx	Missing:	Change to 0.			
		Out of range:	Error B.			
		Floating point:	Error A.			
	nn	Missing:	Error C.			
		Out of range:	Error C.			
Description	When the MM command is sent without preceding controller number or the controller number is 0, the MM command gets executed on all controllers.					
	MM0 changes the controller's state from READY to DISABLE. The current position gets still updated.					
	MM1 changes the controller's state from DISABLE to READY. The controller's set point position is set equal to its current position and the control loop gets closed.					
Returns	If the sign "?" takes place of nn, this command returns the current controller state (ef). Refer to the TS command for the list of controller states.					
Errors	A	—	Unknown message code or floating point controller address.			
	B	—	Controller address not correct.			
	C	—	Parameter missing or out of range.			
	D	—	Execution not allowed.			
	I	—	Execution not allowed in CONFIGURATION state.			
	M	—	Execution not allowed in Motion states.			
Rel. Commands	PW	—	Enter/leave CONFIGURATION state.			
Example	1MM1		<i>The controller #1 goes to READY state.</i>			
	1MM?					
			<i>1MM32</i>			

PA_[a] — Move absolute

	Usage	Config.	Disable	Ready OL	Moving CL	Stepping OL	Jogging OL
		—	—	●	●	—	—
Syntax	xxPA[a]nn or xxPA[a]?						
Parameters							
Description	xx [int]	—	Controller address.				
	a [char]	—	Axe reference				
	nn [float]	—	New target position.				
Range	xx	—	1 to 31				
	a	—	U or V				
	nn	—	> SL and < SR				
Units	xx	—	None.				
	a	—	U or V				
	nn	—	Preset units.				
Defaults	xx Missing:	Error B.					
	Out of range:	Error B.					
	Floating point:	Error A.					
	nn Missing:	Error C.					
	Out of range:	Error C.					
Description	The PA command initiates an absolute move. When received, the positioner will move to the new target position specified by nn .						
	The PA command gets only accepted in READY or MOVING state, AND when the new target position is higher or equal to the negative software limit (SL), AND lower or equal to the positive software limit (SR).						
Returns	If the sign “?” takes place of nn , this command returns the target position value.						
Errors	A	—	Unknown message code or floating point controller address.				
	B	—	Controller address not correct.				
	C	—	Parameter missing or out of range.				
	D	—	Execution not allowed.				
	G	—	Target position out of limits.				
	I	—	Execution not allowed in CONFIGURATION state.				
	J	—	Execution not allowed in DISABLE state.				
	V	—	Unknown axe reference.				
Rel. Commands	PR	—	Move relative.				
	TH	—	Get target position.				
	TP	—	Get current position.				
Example	1PAV0.2		<i>Move positioner on controller #1 to absolute position 0.2 units.</i>				

PR_[a] — Move relative

	Usage	Config.	Disable	Ready OL	Moving CL	Stepping OL	Jogging OL
		—	—	●	●	—	—
Syntax	xxPR[a]nn						
Parameters							
Description	xx [int]	—	Controller address.				
	a [char]	—	Axe reference				
	nn [float]	—	Displacement.				
Range	xx	—	1 to 31				
	a	—	U or V				
	nn	—	> SL and < SR				
Units	xx	—	None.				
	nn	—	Preset units.				
Defaults	xx Missing:	Error B.					
	Out of range:	Error B.					
	Floating point:	Error A.					
	nn Missing:	Error C.					
	Out of range:	Error C.					
Description	The PR command initiates a relative move. When received, the positioner will move to a new target position nn units away from the current target position.						
	The PR command gets only accepted in READY or MOVING state, AND when the distance of the positioner to the end of runs is larger than the commanded displacement.						
Returns	If the sign “?” takes place of nn , this command returns the target position value.						
Errors	A	—	Unknown message code or floating point controller address.				
	B	—	Controller address not correct.				
	C	—	Parameter missing or out of range.				
	D	—	Execution not allowed.				
	G	—	Displacement out of limits.				
	I	—	Execution not allowed in CONFIGURATION state.				
	J	—	Execution not allowed in DISABLE state.				
	V	—	Unknown axe reference.				
Rel. Commands	PA	—	Move absolute.				
	TH	—	Get target position.				
	TP	—	Get current position.				
Example	1PRU0.2		<i>Move positioner on controller #1 to a new position 0.2 units away from the current target position.</i>				

PW — Enter/Leave CONFIGURATION state

Usage	Config.	Disable	Ready OL	Moving CL	Stepping OL	Jogging OL
	●	—	●	—	—	—
Syntax	xxPWnn or xxPW?					
Parameters						
Description	xx [int]	—	Controller address.			
	nn [float]	—	Mode.			
Range	xx	—	1 to 31			
	nn	—	1: Go from READY state to CONFIGURATION state. 0: Go from CONFIGURATION state to READY state.			
Units	xx	—	None.			
	nn	—	None.			
Defaults	xx	Missing:	Error B.			
		Out of range:	Error B.			
		Floating point:	Error A.			
	nn	Missing:	Error C.			
		Out of range:	Error C.			
Description	<p>PW1 changes the controller's state from READY to CONFIGURATION. In Configuration state all parameter settings are saved in the controller's memory and remain available after switching off the controller.</p> <p>PW0 checks all stage parameters, and if they are acceptable, saves them in the flash memory of the controller. After that, it changes the controller's state from CONFIGURATION to READY.</p> <p>The execution of a PW0 command may take up to 5 seconds. During that time the controller will not respond to any other command.</p>					
Returns	If the sign "?" takes place of nn, this command returns the current state.					
Errors	A	—	Unknown message code or floating point controller address.			
	B	—	Controller address not correct.			
	C	—	Parameter missing or out of range.			
	D	—	Execution not allowed.			
	J	—	Execution not allowed in DISABLE state.			
	M	—	Execution not allowed in Motion states.			
Rel. Commands	MM	—	Enter/Leave DISABLE state.			
Example	1PW1		<i>Changes controller #1 to CONFIGURATION state.</i>			

NOTE

The PW command is limited to 100 writes. Unit failure due to excessive use of the PW command is not covered by warranty.

The PW command is used to change the configuration parameters that are stored in memory, and not parameters that are needed to be changed on the fly.

RS — Reset controller

Usage	Config.	Disable	Ready OL	Moving CL	Stepping OL	Jogging OL
	●	●	●	●	●	●
Syntax	xxRS					
Parameters						
Description	xx [int]	—	Controller address.			
Range	xx	—	1 to 31			
Units	xx	—	None.			
Defaults	xx	Missing:	Error B.			
		Out of range:	Error B.			
		Floating point:	Error A.			
Description	The RS command issues a hardware reset of the controller, equivalent to a power-up.					
Errors	A	—	Unknown message code or floating point controller address.			
	B	—	Controller address not correct.			
	D	—	Execution not allowed.			
Example	1RS		<i>Reset controller #1.</i>			

RS## — Reset controller's address

Usage	Config.	Disable	Ready OL	Moving CL	Stepping OL	Jogging OL
	●	●	●	●	●	●
Syntax	xxRS## or RS##					
Parameters						
Description	xx [int]	—	Controller address.			
Range	xx	—	1 to 31			
Units	xx	—	None.			
Defaults	xx	Missing:	Change to 0.			
		Out of range:	Error B.			
		Floating point:	Error A.			
Description	The RS## command resets the controller's address to 1. This address needs to be different for each CONEX devices when connected on a RS-485 communication network.					
	* The minimum endurance of the memory used to store parameters is of 100 write cycles. Users should limit the use of RS## command.					
Returns						
Errors	A	—	Unknown message code or floating point controller address.			
	B	—	Controller address not correct.			
	D	—	Execution not allowed.			
Example	RS##		<i>Reset controller's address to 1.</i>			

SA — Set/Get controller's RS-485 address

Usage	Config.	Disable	Ready OL	Moving CL	Stepping OL	Jogging OL
	○	—	—	—	—	—
Syntax	xxSAnn or xxSA?					
Parameters						
Description	xx [int]	—	Controller address.			
	nn [int]	—	Controller new address.			
Range	xx	—	1 to 31			
	nn	—	1 to 31 and ≠ xx			
Units	xx	—	None.			
	nn	—	None.			
Defaults	xx	Missing:	Error B.			
		Out of range:	Error B.			
		Floating point:	Error A.			
	nn	Missing:	Error C.			
		Out of range:	Error C.			
Description	The SA command sets the controller's RS-485 address. This address is ONLY used when the controller is configured for RS-485 communication.					
	The SA command is of practical use only when not using this software.					
Returns	If the sign "?" takes place of nn, this command returns the current programmed value.					
Errors	A	—	Unknown message code or floating point controller address.			
	B	—	Controller address not correct.			
	C	—	Parameter missing or out of range.			
	D	—	Execution not allowed.			
	J	—	Execution not allowed in DISABLE state.			
	M	—	Execution not allowed in motion states.			
Example	1SA3		<i>Set controller's RS-485 address to 3.</i>			
	3SA?		<i>Get the controller address</i>			
	3SA3					

SL_[a] — Set/Get negative software limit

Usage	Config.	Disable	Ready OL	Moving CL	Stepping OL	Jogging OL
	○	□	□	-	-	-
Syntax	xxSL[a]nn or xxSL[a]?					
Parameters						
Description	xx [int]	—	Controller address.			
	a [char]	—	Axe reference.			
	nn [float]	—	Negative software limit.			
Range	xx	—	1 to 31			
	a	—	U or V			
	nn	—	≥ -1 and ≤ 0			
Units	xx	—	None.			
	nn	—	Deg.			
Defaults	xx	Missing:	Error B.			
		Out of range:	Error B.			
		Floating point:	Error A.			
	nn	Missing:	Error C.			
		Out of range:	Error C.			
Description	<p>In CONFIGURATION state, this command sets the negative software limit which can than be saved in the controller's nonvolatile memory using the PW command. It is also the default value that will be used unless a different value is set in DISABLE or READY state.</p> <p>In DISABLE or READY state, this command allows setting a new working parameter for the negative software limit. It must be lower or equal to the target position. This value is not saved in the controller's memory and will be lost after reboot.</p> <p>The software limits are useful to limit the travel range of a positioner. There is no possibility to disable software limits.</p>					
Returns	If the sign "?" takes place of nn, this command returns the current programmed value.					
Errors	A	—	Unknown message code or floating point controller address.			
	B	—	Controller address not correct.			
	C	—	Parameter missing or out of range.			
	D	—	Execution not allowed.			
	M	—	Execution not allowed in Motion states.			
	V	—	Unknown axe reference.			
Rel. Commands	SR	—	Set positive software limit.			
Example	1SLV-0.5		<i>Set controller #1 negative software limit to -0.5 units for axe V.</i>			

SR_[a] — Set/Get positive software limit

	Usage	Config.	Disable	Ready OL	Moving CL	Stepping OL	Jogging OL
		○	□	□	–	–	–
Syntax	xxSR[a]nn or xxSR[a]?						
Parameters							
Description	xx [int]	—	Controller address.				
	a [char]	—	Axe reference.				
	nn [float]	—	Positive software limit.				
Range	xx	—	1 to 31				
	a	—	U or V				
	nn	—	≥ 0 and ≤ 1				
Units	xx	—	None.				
	nn	—	Deg.				
Defaults	xx	Missing:	Error B.				
		Out of range:	Error B.				
		Floating point:	Error A.				
	nn	Missing:	Error C.				
		Out of range:	Error C.				
Description	<p>In CONFIGURATION state, this command sets the positive software limit which can than be saved in the controller's nonvolatile memory using the PW command. It is also the default value that will be used unless a different value is set in DISABLE or READY state.</p> <p>In DISABLE or READY state, this command allows setting a new working parameter for the positive software limit. It must be larger or equal to the target position. This value is not saved in the controller's memory and will be lost after reboot.</p> <p>The software limits are useful to limit the travel range of a positioner. There is no possibility to disable software limits.</p>						
Returns	If the sign "?" takes place of nn, this command returns the current programmed value.						
Errors	A	—	Unknown message code or floating point controller address.				
	B	—	Controller address not correct.				
	C	—	Parameter missing or out of range.				
	D	—	Execution not allowed.				
	M	—	Execution not allowed in Motion states.				
	V	—	Unknown axe reference.				
Rel. Commands	SL	—	Set negative software limit.				
Example	1SRU0.75		<i>Set controller #1 positive software positive to 0.75 units for axe U.</i>				

ST — Stop motion

	Usage	Config.	Disable	Ready OL	Moving CL	Stepping OL	Jogging OL
		—	—	—	●	●	●
Syntax	[xx]ST						
Parameters							
Description	xx [int]	—	Controller address.				
Range	xx	—	0 to 31				
Units	xx	—	None.				
Defaults	xx	Missing:	Change to 0.				
		Out of range:	Error B.				
		Floating point:	Error A.				
Description	The xxST command with preceding controller address stops a move in progress on controller xx. The ST command without preceding controller address stops the moves on ALL controllers.						
	On the AGAP controllers, this command stops both U and V axes at the same time. The new target positions for both axes are set to the current positions.						
Errors	A	—	Unknown message code or floating point controller address.				
	B	—	Controller address not correct.				
	D	—	Execution not allowed.				
	I	—	Execution not allowed in CONFIGURATION state.				
	J	—	Execution not allowed in DISABLED state.				
	K	—	Execution not allowed in READY state.				
Example	ST		<i>Stop moves on all controllers.</i>				

SU — Set/Get system resolution

Usage	Config.	Disable	Ready OL	Moving CL	Stepping OL	Jogging OL
	○	□	□	-	-	-
Syntax	xxSU \overline{nn} or SU?					
Parameters						
Description	xx [int]	—	Controller address.			
	nn [float]	—	Resolution.			
Range	xx	—	1 to 31			
	nn	—	>0			
Units	xx	—	None.			
	nn	—	Deg.			
Defaults	xx	Missing:	Error B.			
		Out of range:	Error B.			
		Floating point:	Error A.			
Description	The SU command sets or gets the resolution of the system. The device determines the position using analog signals and rounds it to the encoder resolution set using this command.					
Returns	If the sign “?” takes place of nn , this command returns the current programmed value.					
Errors	A	—	Unknown message code or floating point controller address.			
	B	—	Controller address not correct.			
	D	—	Execution not allowed.			
Rel. Commands	DB	—	Set/Get corrector deadband.			
Example	1SU0.0005		Set the <i>controller #1</i> resolution to 0.5 mdeg.			

TB — Get command error string

Usage	Config.	Disable	Ready OL	Moving CL	Stepping OL	Jogging OL
	●	●	●	●	●	●
Syntax	xxTBnn					
Parameters						
Description	xx [int]	—	Controller address.			
Range	xx	—	1 to 31			
	nn [char]	—	Error code (refer to TE command).			
Units	xx	—	None.			
Defaults	xx	Missing:	Error B.			
		Out of range:	Error B.			
		Floating point:	Error A.			
	nn	Missing:	Returns explanation of current error.			
		Out of range:	Error C.			
Description	The TB command returns a string that explains the meaning of the error code nn (see TE command for complete list).					
Errors	A	—	Unknown message code or floating point controller address.			
	B	—	Controller address not correct.			
	C	—	Parameter missing or out of range.			
	D	—	Execution not allowed.			
Rel. Commands	TE	—	Get error code.			
Example	1TB@		<i>Get explanation to error code @.</i>			
	<i>1TB@ No error Controller returns: @ = means no error.</i>					

TE — Get last command error

Usage	Config.	Disable	Ready OL	Moving CL	Stepping OL	Jogging OL
	●	●	●	●	●	●
Syntax	xxTE					
Parameters						
Description	xx [int]	—	Controller address.			
Range	xx	—	1 to 31			
Units	xx	—	None.			
Defaults	xx	Missing:	Error B.			
		Out of range:	Error B.			
		Floating point:	Error A.			
Description	<p>The TE command returns the currently memorized error. When a command is not executable, it memorizes an error. This error can be read with the TE command. After the execution of a TE command, the error buffer gets erased and another TE command will return @, means no error. When a new command error is generated before the previous command error is read, the new command error will overwrite the current memorized error.</p> <p>For a safe program flow it is recommended to always query the command error after each command execution.</p>					
Errors	A	—	Unknown message code or floating point controller address.			
	B	—	Controller address not correct.			
	D	—	Execution not allowed.			
Rel. Commands	TB	—	Get error string.			
Example	1TE		<i>Get last error memorized on controller #1.</i>			
			<i>Controller returns: 1TE@, means no error.</i>			
	List of errors and corresponding strings (see TB command):					
	@	—	No error.			
	A	—	Unknown message code or floating point controller address.			
	B	—	Controller address not correct.			
	C	—	Parameter missing or out of range.			
	D	—	Command not allowed.			
	G	—	Displacement out of limits.			
	I	—	Command not allowed in CONFIGURATION state.			
	J	—	Command not allowed in DISABLE state.			
	K	—	Command not allowed in READY state.			
	M	—	Command not allowed in motion states.			
	N	—	Current position out of software limit.			
	S	—	Communication Time Out.			
	U	—	Error during EEPROM access.			
	V	—	Unknown axe reference.			

TH_[a] — Get target position

	Usage	Config.	Disable	Ready OL	Moving CL	Stepping OL	Jogging OL
		●	●	●	●	—	—
Syntax	xxTH[a] or xxTH						
Parameters							
Description	xx [int]	—	Controller address.				
	a [char]	—	Axe reference.				
Range	xx	—	1 to 31				
	a	—	U or V				
Units	xx	—	None.				
Defaults	xx	Missing:	Error B.				
		Out of range:	Error B.				
		Floating point:	Error A.				
Description	The TH command returns the value of the unrounded target position. This is the position where the positioner should be. The target position rounded to the device resolution is given by the commands PR[a]? and PA[a]?.						
Errors	A	—	Unknown message code or floating point controller address.				
	B	—	Controller address not correct.				
	D	—	Execution not allowed.				
Rel. Commands	TP	—	Get current position.				
Example	1THU		<i>Get target position of axe U of controller #1.</i>				
	1THU0.0023512		<i>Controller returns: target position for axe U = 0.0023512 units.</i>				

TP_[a] — Get current position

Usage	Config.	Disable	Ready OL	Moving CL	Stepping OL	Jogging OL
	●	●	●	●	●	●
Syntax	xxTP[a] or xxTP					
Parameters						
Description	xx [int]	—	Controller address.			
	a [char]	—	Axe reference.			
Range	xx	—	1 to 31			
	a	—	U or V			
Units	xx	—	None.			
Defaults	xx	Missing:	Error B.			
		Out of range:	Error B.			
		Floating point:	Error A.			
Description	<p>The TP command returns the value of the current position. This is the position where the positioner actually is according to his encoder value. In MOVING state, this value always changes. In READY state, this value should be equal or very close to the target position.</p> <p>Together with the TS command, the TP command helps evaluating whether a motion is completed.</p>					
Errors	A	—	Unknown message code or floating point controller address.			
	B	—	Controller address not correct.			
	D	—	Execution not allowed.			
Rel. Commands	TH	—	Get target position.			
Example	1TPU		<i>Get current position of axe U of controller #1.</i>			
	1TPU0		<i>Controller returns: actual position for axe U = 0 units.</i>			

TS — Get positioner error and controller state

Usage	Config.	Disable	Ready OL	Moving CL	Stepping OL	Jogging OL
	●	●	●	●	●	●
Syntax	xxTS					
Parameters						
Description	xx [int]	—	Controller address.			
Range	xx	—	1 to 31			
Units	xx	—	None.			
	nn	—	None.			
Defaults	xx	Missing:	Error B.			
		Out of range:	Error B.			
		Floating point:	Error A.			
Description	The TS command returns the positioner error and the current controller state. The motion time out flag is always set with one of the two-associated following error.					
Returns	The TS command returns six characters (ITSabcdef). The first 4 characters (abcd) represent the positioner error in Hexadecimal. The last two characters (ef) represent the controller state.					

Error code (abcd): Convert each hexadecimal to a binary:

F	E	D	C	B	A	9	8	7	6	5	4	3	2	1	0
1111	1110	1101	1100	1011	1010	1001	1000	0111	0110	0101	0100	0011	0010	0001	0000

E
Each bit represents one possible error:

A				B				C				D			
1	1	1	1	1	1	1	1	1	1	1	1	1	1	1	1
• Not used	• Not used	• Not used	• Not used	• Not used	• Not used	• Not used	• Not used	• Not used	• Not used	• Motion Time out	• Not used	• Not used	• Not used	• Not used	• Not used

Examples:

- Error map 0000 = No errors
- Error map 0020 = Motion time out.

Controller states (ef):

- **14:** CONFIGURATION.
- **28:** MOVING CL.
- **29:** STEPPING OL.
- **32:** READY from Reset.
- **33:** READY from MOVING CL.
- **34:** READY from DISABLE.
- **35:** READY from JOGGING OL
- **36:** READY from STEPPING OL.
- **3C:** DISABLE from READY OL.
- **3D:** DISABLE from MOVING CL.
- **46:** JOGGING OL.

NOTES

THE ERROR BUFFER GETS UPDATED PERIODICALLY, APPROX. EVERY 1 MS.

THE TS COMMAND READS THE ERROR BUFFER AND CLEARS THE ERROR BUFFER AT THE SAME TIME (SAME AS FOR COMMANDS TE, TB). SO WHEN LAUNCHING THE TS COMMAND, IT IS IMPORTANT TO PROCESS THE TS FEEDBACK ACCORDINGLY

Errors	A	—	Unknown message code or floating point controller address.
	B	—	Controller address not correct.
Rel. Commands	TE	—	Get last error.
Example	1TS		<i>Get error and state of controller #1.</i>
	ITS000032		<i>Controller returns: no errors and READY from reset.</i>

VE — Get controller revision information

Usage	Config.	Disable	Ready OL	Moving CL	Stepping OL	Jogging OL
	●	●	●	●	●	●
Syntax	xxVE					
Parameters						
Description	xx [int]	—	Controller address.			
	nn [string]	—	Action.			
Range	xx	—	1 to 31			
Units	xx	—	None.			
Defaults	xx	Missing:	Error B.			
		Out of range:	Error B.			
		Floating point:	Error A.			
Description	This command returns the controller's revision information.					
Errors	A	—	Unknown message code or floating point controller address.			
	B	—	Controller address not correct.			
Rel. Commands	TP	—	Get current position.			
Example	1VE		<i>Get controller #1 revision information.</i>			
	<i>1VE CONEX-AGAP V1.0.0. Controller returns revision number</i>					

XR_[a] — Step motion

	Usage	Config.	Disable	Ready OL	Moving CL	Stepping OL	Jogging OL
		—	—	●	—	—	—
Syntax	xxXR[a]nn						
Parameters							
Description	xx [int]	—	Controller address.				
	a [char]	—	Axe reference.				
	nn [int]	—	Number of steps.				
Range	xx	—	1 to 31				
	a	—	U or V				
	nn	—	≥ -10 ⁶ and ≤ 10 ⁶				
Units	xx	—	None.				
Defaults	xx	Missing:	Error B.				
		Out of range:	Error B.				
		Floating point:	Error A.				
Description	Starts a relative move of nn steps with step amplitude defined by the XU command. At the end of the motion, the target position of the axe takes the value of the current axe position.						
Errors	A	—	Unknown message code or floating point controller address.				
	B	—	Controller address not correct.				
	I	—	Execution not allowed in CONFIGURATION state.				
	J	—	Execution not allowed in DISABLED state.				
	M	—	Execution not allowed in Motion states.				
	V	—	Unknown axe reference.				
Rel. Commands	TP	—	Get current position.				
	XU[a]	—	Set/Get step motion size.				
Example	1XRU100		<i>Set controller #1 step number on axe U.</i>				

XU_[a] — Set/Get step motion size

Usage	Config.	Disable	Ready OL	Moving CL	Stepping OL	Jogging OL
	☐	☐	☐	–	–	–
Syntax	xxXU[a]nn or xxXU[a]?					
Parameters						
Description	xx [int]	—	Controller address.			
	a [char]	—	Axe reference			
	nn [int]	—	Step size.			
Range	xx	—	1 to 31			
	a	—	U or V			
	nn	—	-50 to +50			
Units	xx	—	None.			
Defaults	xx	Missing:	Error B.			
		Out of range:	Error B.			
		Floating point:	Error A.			
Description	Sets the step amplitude (step size) in positive or negative direction. If the parameter is positive, it will set the step amplitude in the forward direction. If the parameter is negative, it will set the step amplitude in the backward direction.					
NOTES						
The step amplitude is a relative measure. The step amplitude corresponds to the amplitude of the electrical signal sent to the Agilis motor. There is no linear correlation between the step amplitude and the effective motion size. In particular, too low a setting for the step amplitude may result in no output motion. Also, the same step amplitude setting for forward and backward direction may result in different size motion steps. Also, the motion step size corresponding to a step amplitude setting may vary by position, load, and throughout the life time of the product. The step amplitude setting is not stored after power down. The default value after power-up is 35.						
Errors	A	—	Unknown message code or floating point controller address.			
	B	—	Controller address not correct.			
	M	—	Execution not allowed in Motion states.			
	V	—	Unknown axe reference.			
Rel. Commands	TP	—	Get current position.			
	XR[a]	—	Step motion.			
Example	1XUU20		<i>Set controller #1 step size to 20 on axe U.</i>			

ZT — Get all configuration parameters

Usage	Config.	Disable	Ready OL	Moving CL	Stepping OL	Jogging OL
	●	●	●	—	—	—
Syntax	xxZT					
Parameters						
Description	xx [int]	—	Controller address.			
Range	xx	—	1 to 31			
Units	xx	—	None.			
Defaults	xx	Missing:	Error B.			
		Out of range:	Error B.			
		Floating point:	Error A.			
Description	The ZT command returns the list of all current configuration parameters.					
Errors	A	—	Unknown message code or floating point controller address			
	B	—	Controller address not correct			
	M	—	Execution not allowed in Motion states.			
Rel. Commands	TE	—	Get error code.			
Example	1ZT		<i>Get controller #1 configuration data.</i>			
	1PW1					
	1IDAG-M100D					
	1SA1					
	1SLU-1					
	1SRU1					
	...					
	1PW0					

3.0 Connector interfaces

3.1 USB (Male mini-USB)

1 2 3 4 5



USB

Mating connector:
Plug Mini-USB B 5 cts

PIN	DESCRIPTION
1	+5VdcIN Do not connect if comm connector is used
2	DATA-
3	DATA+
4	NC
5	GND



Visit Newport Online at:
www.newport.com

North America & Asia

Newport Corporation
1791 Deere Ave.
Irvine, CA 92606, USA

Sales

Tel.: (800) 222-6440
e-mail: sales@newport.com

Technical Support

Tel.: (800) 222-6440
e-mail: tech@newport.com

Service, RMAs & Returns

Tel.: (800) 222-6440
e-mail: service@newport.com

Europe

MICRO-CONTROLE Spectra-Physics S.A.S
9, rue du Bois Sauvage
91055 Évry CEDEX
France

Sales

Tel.: +33 (0)1.60.91.68.68
e-mail: france@newport.com

Technical Support

e-mail: tech_europe@newport.com

Service & Returns

Tel.: +33 (0)2.38.40.51.55

