

ACCESSORIES

MODEL	DESCRIPTION
74009	Monochromator Hand Controller
USFW-100	Universal Filter Wheel
CBL-CSMS-FW	Filter Wheel Cable
TRACQ-BASIC-V066	TracQ Basic Data Acquisition Software

ORDERING INFORMATION

Model	Description
CS130B-1-FH	1/8m Monochromator, High Resolution, Fixed Slits
CS130B-1-MC	1/8m Monochromator, High Resolution, Micrometer Slits
CS130B-2-FH	1/8m Monochromator, Holographic, Fixed Slits
CS130B-2-MC	1/8m Monochromator, Holographic, Micrometer Slits
CS130B-3-FH	1/8m Monochromator, Extended Range, Fixed Slits
CS130B-3-MC	1/8m Monochromator, Extended Range, Micrometer Slits
CS130B-4-FH	1/8m Monochromator, Near IR, Fixed Slits
CS130B-4-MC	1/8m Monochromator, Near IR, Micrometer Slits
70044	USB 2.0 Cable, 3m
77294	Fixed Slit Holder
74001	Micrometer Adjustable Slit

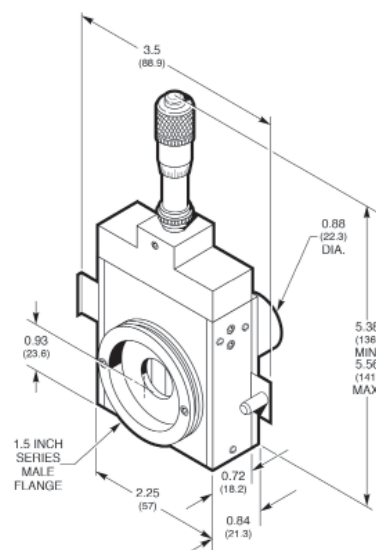

Dimension drawing of the Micrometer Adjustable Slit Assembly

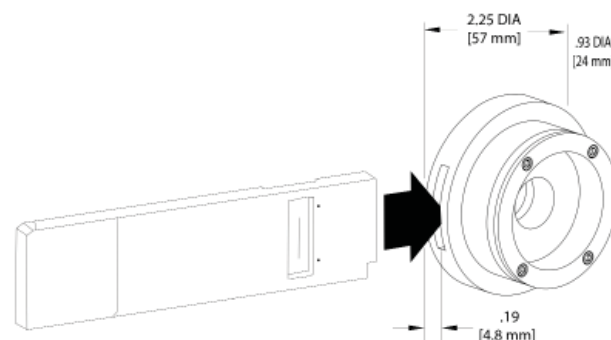

Dimension drawing of the Fixed Slit Holder Assembly

Cornerstone™ 130B 1/8 m Monochromators



The Oriel® Cornerstone™ 130B is a high performance, economical, and user-friendly monochromator - an ideal instrument for research and OEM applications. Oriel has made it easy to choose the right monochromator based on the application, with a wide selection of diffraction gratings covering the full wavelength spectrum to fit most needs. Choosing a Cornerstone 130B model is based upon:

- Wavelength range of interest
- Input and output slit type

WHAT'S INCLUDED

Each Cornerstone 130B monochromator includes:

The Cornerstone 130B monochromator is available in a number of different configurations. The model shown here uses micrometer adjustable slits at the input and output port providing flexibility and high throughput.

- Models available for UV to NIR applications
- Motorized wavelength and grating selection
- Choice of micrometer adjustable slits or fixed slits
- Interfaces USB, RS232, or optional hand controller
- Includes utility software at no extra cost

- Two diffraction gratings, installed and aligned
- Electronic shutter at input port
- A choice of micrometer adjustable slits or fixed slit holders at the input and output ports
- A MPT plug to accept a hose barb to purge the instrument compartment for measurements below 180 nm (actual capability is grating configuration dependent)
- LabVIEW™ based utility software
- Application Programming Interface (API) for LabVIEW™ with examples
- Certificate of calibration
- Monochromator power supply
- Line cords based on geographic location
- User's manual

For monochromators featuring fixed slit holders, a variety of fixed slit sizes are available. The input and output slits should be the same size (ordered separately).



Newport Corporation

31950 Frontage Road Bozeman, MT, USA

PHONE: 1-800-459-9459 1-406-556-2481 FAX: 1-406-586-9405 EMAIL: OrielPV.sales@newport.com

Complete listings for all global office locations are available online at www.newport.com/contact

www.newport.com

Newport Corporation, Irvine, California and Franklin, Massachusetts; Evry and Beaune-la-Rolande, France and Wuxi, China have all been certified compliant with ISO 9001 by the British Standards Institution. Santa Clara, California is DNV certified. © 2014-2017 Newport Corporation. All rights reserved.



Lightweight molded plastic cover, sealed to block stray light, coated to block IR



Both RS232 and upgraded USB test and measurement class communication with upgraded interface functionality

Optical axis, height, and footprint maintained from previous design for drop-in replacement

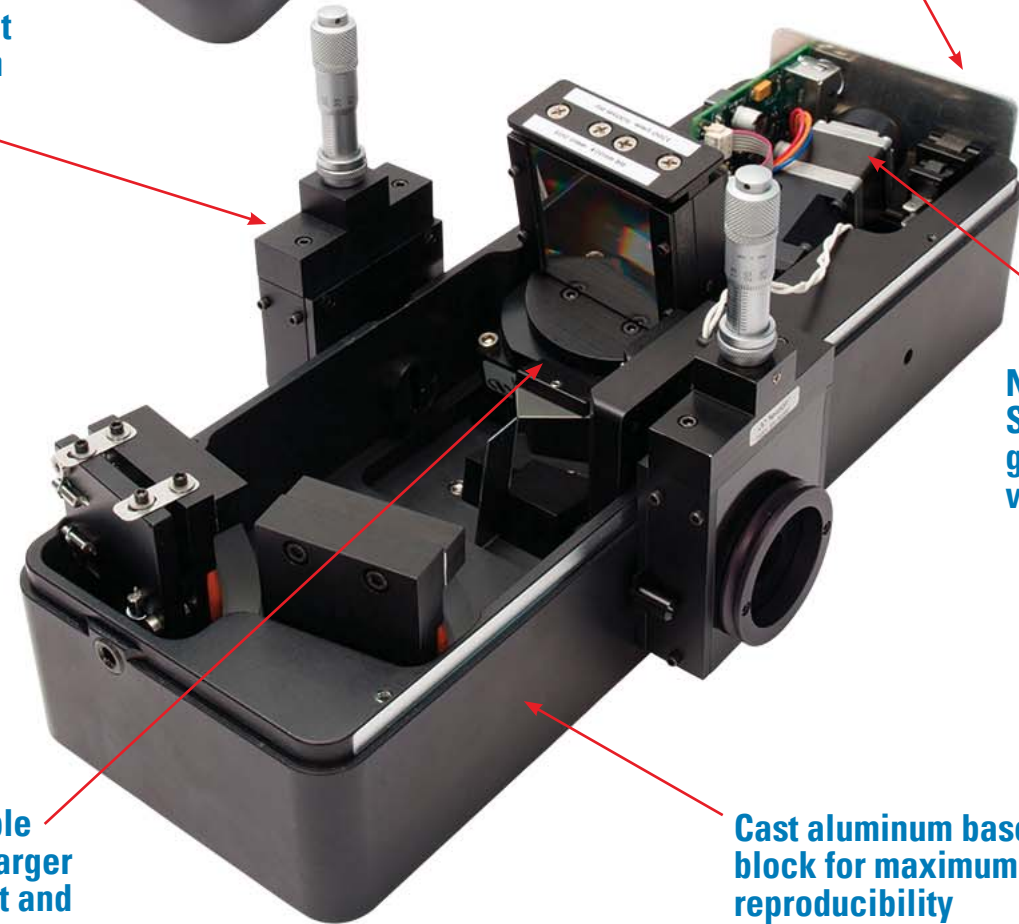

Newport URS Precision Rotation Stage for fast, accurate, repeatable grating change and high resolution wavelength tuning

Improved optical design for simple alignment and calibration with larger gratings for maximum throughput and consistency

Cast aluminum base from a single block for maximum rigidity and reproducibility

CORNERSTONE™ 130B SPECIFICATIONS

Focal Length	130
F/#	F/3.9
Wavelength Selection Range	Motorized
Usable Wavelength Range	280 to 2500 nm, grating dependent
Spectral Resolution	Grating slit width dependent
Wavelength Accuracy	±0.25 nm
Wavelength Precision	±0.075 nm
Stray Light	0.03%
Ports	1 input port, 1 output port
Shutter Control	Software, hand controller, low-level commands
Shutter Minimum Exposure Time	0.3 s
Shutter Maximum Repetition Rate	2 Hz
Wavelength Scan Speed	3 nm/s at 1 nm step rate; 24 nm/s at 10 nm step rate
Motorized Filter Wheel Compatibility	Model USFW-100, 74010, Apex2 filter wheel
Utility Software Requirements	Windows® 10 and MAC OS-X
TracQ Basic Software Compatible	Yes
74009 Hand Controller Compatible	Yes
Voltage	100-240 VAC, 47-63 Hz
Weight	6.9 lbs. (3 kg.)

Wavelength Accuracy: the capability of the monochromator to output the desired wavelength
Wavelength Precision: the ability of a wavelength to be consistently reproduced and the number of significant digits to which it has been reliably measured

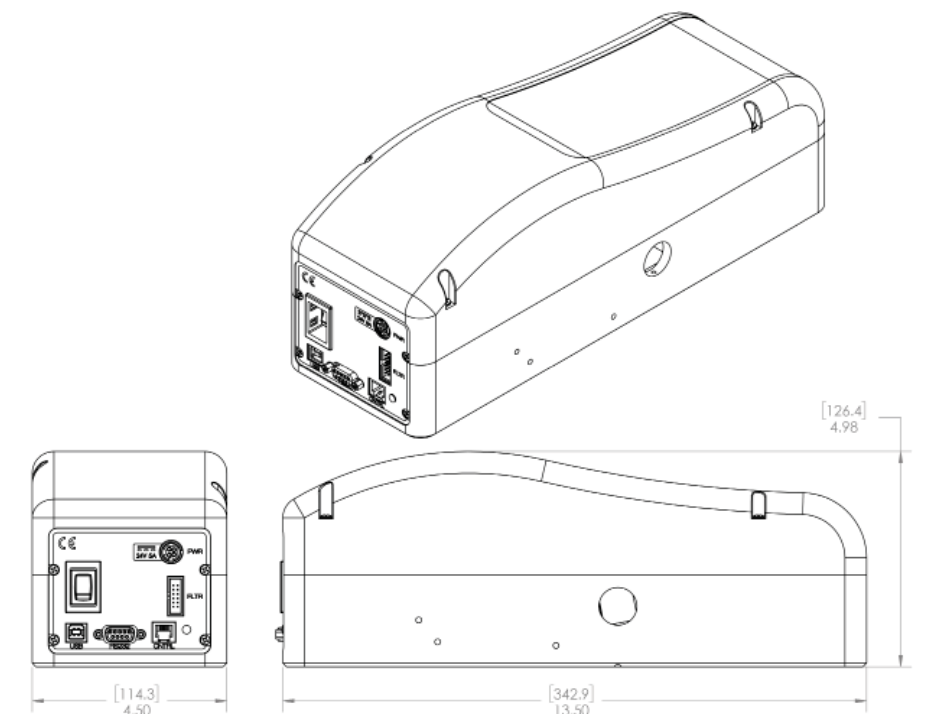

Dimension drawing of the Cornerstone 130B monochromator. Instruments are configured with micrometer adjustable slits or fixed slit holders depending on the model.