

# Agilis™ Series

## Piezo Motor Driven Positioners



*For Motion, Think Newport™*

 **Newport®**

Experience | Solutions

# Agilis™ Series

## Piezo Motor Driven Positioner

### Agilis Series Advantages

- ▶ Proprietary Piezo technology offers numerous advantages over competing designs
  - ▶ Highly precise, and repeatable incremental motion steps in all Agilis Positioners
  - ▶ Innovative miniature encoder technology with closed loop operation in CONEX-Agilis positioners
  - ▶ Set-and-forget long-term stability
  - ▶ Robust design for uninterrupted use and long life
  - ▶ Ultra-compact — ideal for system integration
- All this at a price comparable to a high quality manual positioner



### The inspiration for Agilis

Even small changes in an optics path can produce effects that are propagated and amplified throughout the path. These effects are often detrimental to experimental or observational results. Returning the optics system to optimal path alignment can be difficult, tedious, and access may be limited by the level of optical system integration or placement of the system relative to the user.

The Agilis series by offering remote control, integrated encoders with position feedback, high adjustment sensitivity and in-position stability can now remove the difficulty and uncertainty from your optical setup. With motorized optics mounts, rotary stages, linear stages and compact controllers with full-command sets, there is a solution for every optical setup and sample positioning application.

### A new solution in piezo positioning

Agilis series positioners are based on patented Newport piezo direct motor technology. Featuring a piezo ceramic embedded in a highly engineered spring blade. Agilis motors are directly coupled to the sample/optics platform without errors introduced by intervening mechanisms. This design provides excellent adjustment sensitivity, predictable small motion steps, longer life, higher motion speeds and freedom from problems associated with backlash or hysteresis.

Agilis series positioners feature: optical mounts, rotary stages, linear stages and controllers. With innovative miniature encoders, Agilis products now offer closed loop operation, ideal for precise positioning of optics, sensors or other lightweight samples. With compact controllers, integrated encoder technology, compact design, high performance, and low cost, Agilis positioners are an excellent option for system integration and OEM applications.

## Why Agilis positioners?

- ▶ I have an optical setup that requires fine adjustments that require encoder feedback
- ▶ I have an optical setup that requires frequent alignment adjustments
- ▶ I can benefit from remote access and adjustment to my optics path
- ▶ I have lightweight sample positioning applications
- ▶ I need an affordable piezo positioning system

## The driving force behind Agilis

Agilis series motorized positioners are driven by the patented Agilis piezo direct motor. Agilis motors are built using a piezo ceramic embedded in an engineered spring blade with a special geometry. The motor is controlled by sending a calibrated asymmetric electrical pulse to the piezo ceramic to drive the motor in both positive and negative directions. The motors are directly coupled to optics/sample platform, providing motion free of errors typically associated with intervening mechanisms, such as backlash or hysteresis. The robust design of the piezo motor provides reliable performance and uninterrupted use. This spring also locks position when not in operation, providing set-and-forget stability to optical setups.

When the optimized motor design is integrated with the high level mechanical design and construction Newport is known for, the results are highly repeatable, high precision nanometer scale piezo positioning.

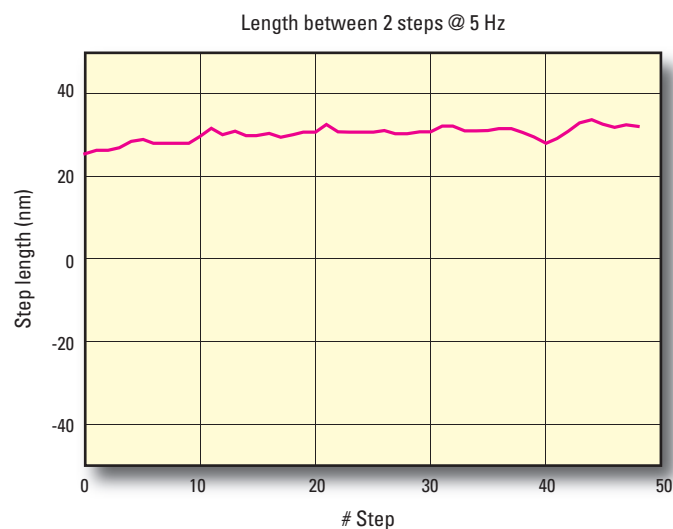

StepMeanLength = 30.3 nm

3 StandartDeviation = 5.3 nm

*Interferometer measurement of the incremental motion capability of an Agilis AG-LS25 linear stage. The stage is capable of making increments of less than 50 nm with very low deviation of the individual step size (accurate adjustment of the step amplitude to the application is required).*

## Agilis absolute positioning and innovative encoder technology

Innovative miniature encoder technologies incorporated in CONEX-Agilis positioners, offer highly integrated position measuring systems without compromising compact construction. CONEX-Agilis rotary and linear stages are built with integrated direct read linear encoders, and CONEX-Agilis optical mounts include integrated strain gauges for absolute positioning capability. With CONEX-Agilis optical mounts returning to saved positions is possible, even after power cycling.

CONEX-Agilis Closed-Loop positioners are ideal for systems integration, with compact integrated controllers, position measurement capability, high position repeatability, consistent incremental motion steps and remote operation with a complete command sets; The CONEX-Agilis series offers an ideal solution for OEM and systems integration applications.

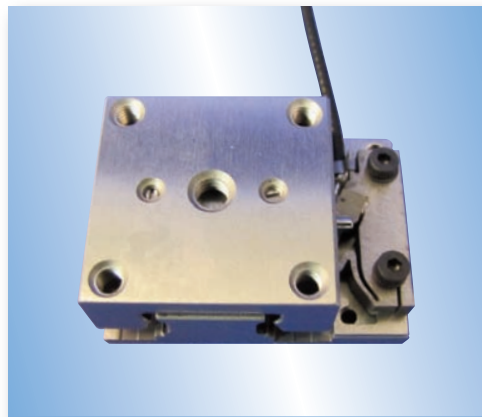

*A top down view showing the profile of an Agilis piezo motor integrated on the AG-LS25 linear stage. The direct coupling and special shape of the custom engineered spring blade, provides excellent motion performance and robust design for uninterrupted use.*

# Agilis™ AG-M050 and AG-M100 mirror mounts



## Specifications

Model	AG-M050	AG-M100
Optic Diameter [in. (mm)]	0.5 (12.7)	1 (25.4)
Angular Travel Range (°)	±2	±2
Minimum Incremental Motion (μrad)	2	1
Maximum Speed (°/s)	1.5	0.75
Angular Accuracy (°)	0.05	0.05
Temperature Stability (μrad/°C)	7	4

The AG-M050 and AG-M100 are motorized mirror mounts for 0.5" and 1" Optics. Agilis mirror mounts are an excellent choice for the most sensitive optical adjustments. Integrated Agilis piezo direct motors driving each pivot axis, offer not only high adjustment sensitivity, but also incremental motion steps with minimal deviation. With a patented clear quadrant design, the full surface area of the optic is exposed to the optics edge, allowing maximum range of use for the optic.

The AG-M050L and AG-M100L offer proprietary integrated limit switches, which can be used to determine average incremental step size, as well as a safety feature.

For vacuum or high-class clean room applications, select mounts ending with V6. These mounts are especially prepared and tested up to  $10^{-6}$  hPa ( $7.5 \times 10^{-7}$  Torr) vacuum.

### Models AG-M050

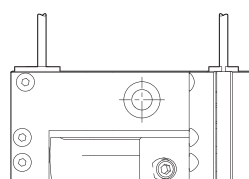
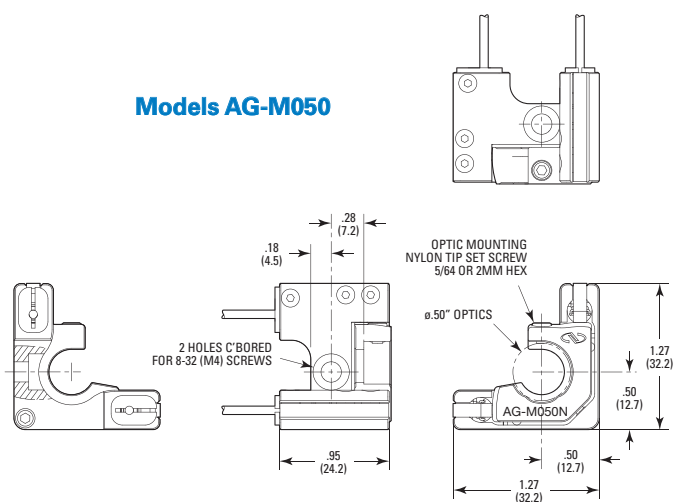

### Models AG-M100

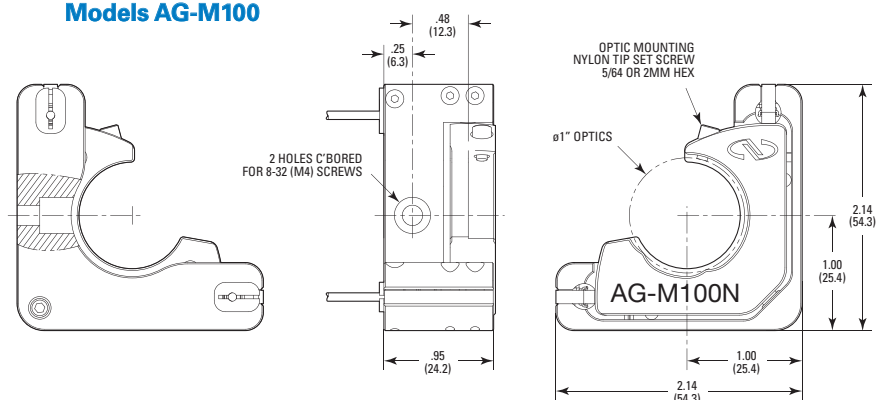

## CONEX-AG-M100D mirror mount



### Specifications

Optic Diameter [in. (mm)]	1.0 (25.4)
Angular Travel Range (°)	±0.75
Closed Loop MIM (°)	0.001
Open Loop MIM (°)	0.0001
Maximum Speed (°/s)	0.4
Repeatability (°)	0.01
Angular accuracy (°)	<0.05
Angular repeatability (°)	±0.005
Temperature Stability (μrad/°C)	5

The CONEX-AG-M100D is a motorized mirror mount based on the AG-M100 with an innovative miniature integrated absolute angle position sensor. The absolute position sensor not only provides position measurement and highly repeatable positioning, but also enables the recovery of a previously-saved positions even after power cycling. Built on the proven Agilis piezo direct motor technology, the CONEX-AG-M100D offers excellent adjustment sensitivity and robust design for uninterrupted use.

Integrated with a compact CONEX-AGAP motion controller/driver, the CONEX-AG-M100D is an excellent choice for OEM applications and system integration. With remote interfacing and absolute positioning, you can be assured you will always know the alignment of your optics path.

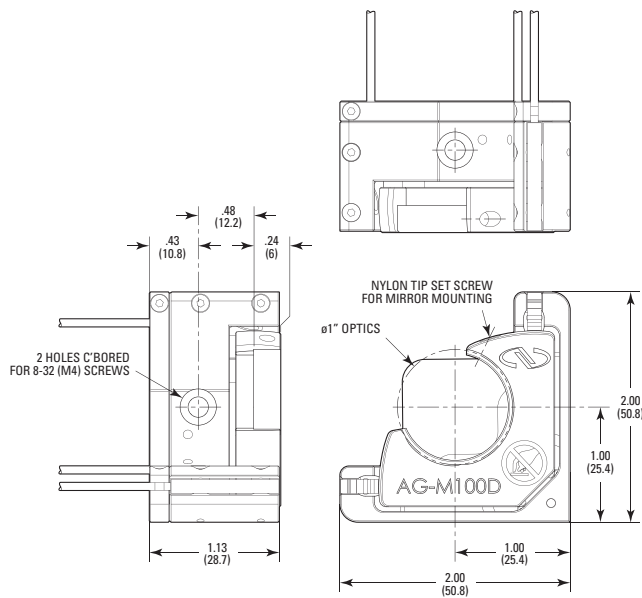

# Agilis AG-LS25 and AG-LS25-27 linear stages



## Specifications

Model	AG-LS25	AG-LS25-27
Travel Range (mm)	12	27
Minimum Incremental Motion, Linear ( $\mu\text{m}$ )	0.05	0.1
Maximum Speed (mm/s)	>0.5	>0.5
Pitch ( $\mu\text{rad}$ )	200	200
Yaw ( $\mu\text{rad}$ )	200	200
Normal Load Capacity, Cz (N)	3	2.5



The Agilis AG-LS25 and AG-LS25-27 are high precision, miniature, piezo motor driven linear stages based on patented Agilis technology. Precision motion is achieved using calibrated, pre-stressed linear ball bearings. The thermally matched stainless steel design and precision manufactured bearing surfaces provide ripple-free, low friction linear travel with minimal angular deviations.

For vacuum applications, the AG-LS25 is available in a vacuum compatible version tested for compatibility to  $10^{-6}$  hPa ( $7.5 \times 10^{-7}$  Torr).

### AG-LS25

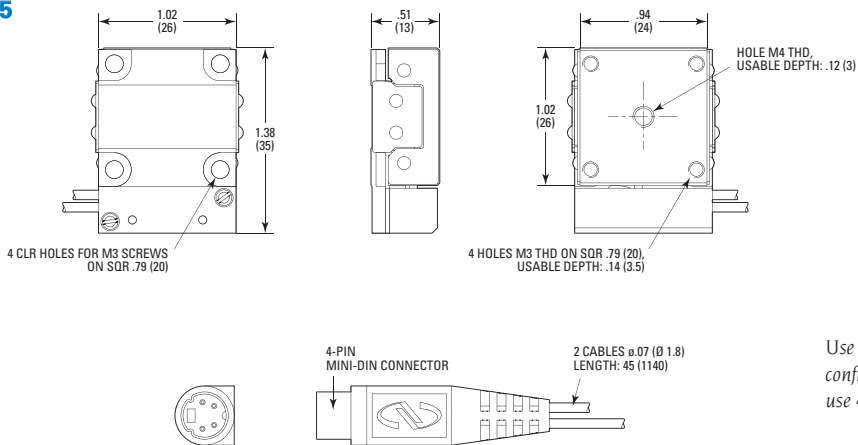

Use the 339233 bracket for XZ and XYZ configurations. For XY assemblies of AG-LS25 stages, use 4 x TC M3x4 screws supplied with each stage.

### AG-LS25-27

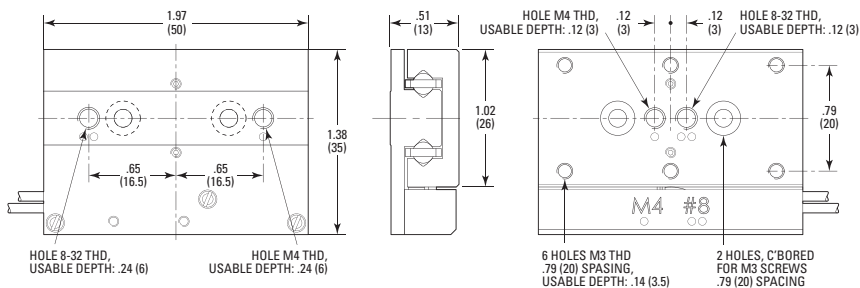

B-Series adapter plates for mounting the AG-LS25 to optical tables and other 40 x 40 mm stages (see [www.newport.com](http://www.newport.com) for details). For mounting AG-LS25 stages to these plates, use 4 x TC M2x4 screws plus washers supplied with each AG-LS25 stage.

# CONEX-AG-LS25-27P linear stage



## Specifications

Travel Range (mm)	27
Minimum Incremental Motion ( $\mu\text{m}$ )	0.2
Maximum Speed (mm/s)	0.4
On-Axis Accuracy, Guaranteed ( $\mu\text{m}$ )	20
Uni-directional Repeatability, Guaranteed ( $\mu\text{m}$ )	0.2
Bi-directional Repeatability, Guaranteed ( $\mu\text{m}$ )	0.3
Origin Repeatability ( $\mu\text{m}$ )	0.2
Pitch, Yaw, Guaranteed ( $\mu\text{rad}$ )	200
Compliance	
$k_{\text{cox}}$ , Compliance in roll ( $\mu\text{rad}/\text{Nm}$ )	550
$k_{\text{coy}}$ , Compliance in pitch ( $\mu\text{rad}/\text{Nm}$ )	350
$k_{\text{coz}}$ , Compliance in yaw ( $\mu\text{rad}/\text{Nm}$ )	300
Load Capacity (N)	2.5

Guaranteed specifications are by design.

The CONEX Agilis AG-LS25-27P is based on the Agilis AG-LS25-27 linear stage, but features an innovative miniature direct read linear encoder. Offering closed loop operation with position feedback and high repeatability, the CONEX-AG-LS25-27P is ideal for sample/optics positioning. To provide maximum stability in set-position, the user can adjust a deadband parameter to stop dithering within a user defined position tolerance.

With position measurement and closed operation, highly precise and repeatable incremental motion steps, stability in set position, compact size and compact integrated controller, the CONEX-AG-LS25-27P is ideal for integrated OEM applications. In addition, RS-232 and RS-485 communication is available at the board level of the controller.

For applications in vacuum, please refer to Agilis positioners with part numbers ending in V6, prepared and tested for vacuum down to  $10^{-6}$  hPa or ( $7.5 \times 10^{-7}$  Torr).

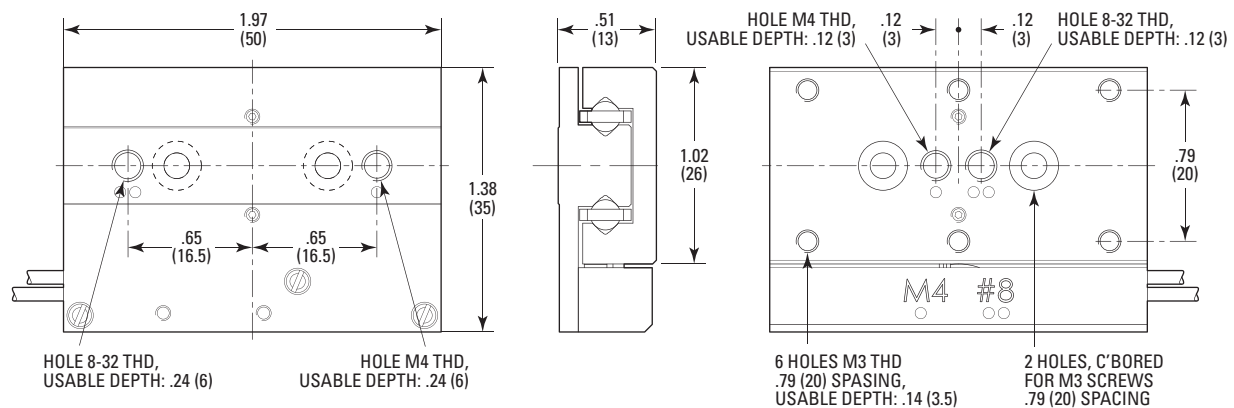



## Agilis™ AG-PR100 rotation stage

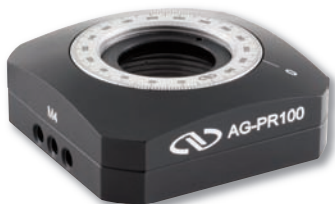

### Specifications

Travel Range (°)	360 continuous
Minimum Incremental Motion (°)	0.0002
Maximum Speed (°/s)	2
Wobble (μrad)	100
Cz, Normal Load Capacity (N)	2
Q, Off-center load (N)	$Q \leq Cz/(1 + D/16)$ where D = Cantilever distance in mm
Graduation (°)	2

The AG-PR100 is an ultra-compact rotation stage based on the patented Agilis piezo direct motor. Incorporating a proprietary ball bearing design that minimizes wobble, the AG-PR100 is ideal for rotational adjustment of polarizing optics, waveplates, or other lightweight samples. The AG-PR100 also offers in-position stability,

with the Agilis piezo motor providing a spring action locking force your optical setup will stay in your preferred configuration.

For vacuum compatible Agilis products please refer to product numbers ending in V6.

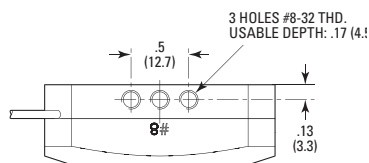

The AG-PR100 is post-mountable, shown above, and is compatible with metric and imperial threads. The coarse position can be read from the laser engraved scale, with 2° graduations.

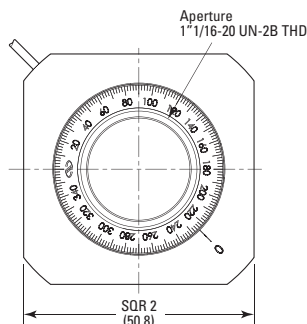
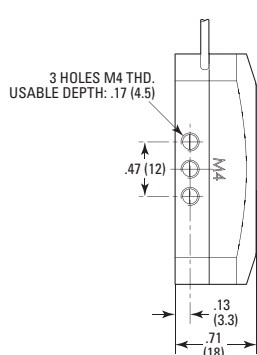

# CONEX-AG-PR100P rotation stage

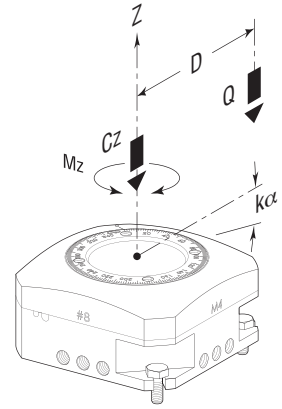

## Specifications

Travel Range	340°, continuous
Minimum Incremental Motion (°)	0.001
Maximum Speed (°/s)	1.5
On-Axis Accuracy, Typical (°)	0.08
Uni-directional Repeatability Typical (°)	0.002
Bi-directional Repeatability, Typical (°)	0.003
Origin Repeatability (°)	0.002
Wobble, Typical (μrad)	100
Mz, Maximum Torque (Nm)	0.02
kx, Transversal Stiffness (μrad/Nm)	200
Cz, Normal Load Capacity (N)	2
Q, Off-center load (N)	$Q \leq Cz/(1 + D/16)$
where D = Cantilever distance in mm	

The CONEX-AG-PR100P is a piezo motor rotary stage with an innovative miniature direct red encoder and an integrated closed-loop piezo motor controller/driver. Initially targeted for repeatable positioning of polarizing optics, it can also be used as a miniature rotation stage for precision positioning of optics or lightweight samples. The Integrated CONEX-AGP uses a closed-loop algorithm that is a simplified version of the typical DC servo loop algorithm, and combined with the rotary encoder, provides a system repeatability of 0.002°.

Designed for optimal position stability, the AG-PR100P offers a deadband parameter that stops dithering when the stage is within a user defined position tolerance. As with other positioners in the Agilis series of products, the AG-PR100P offers true set-and-forget long term stability when not powered.

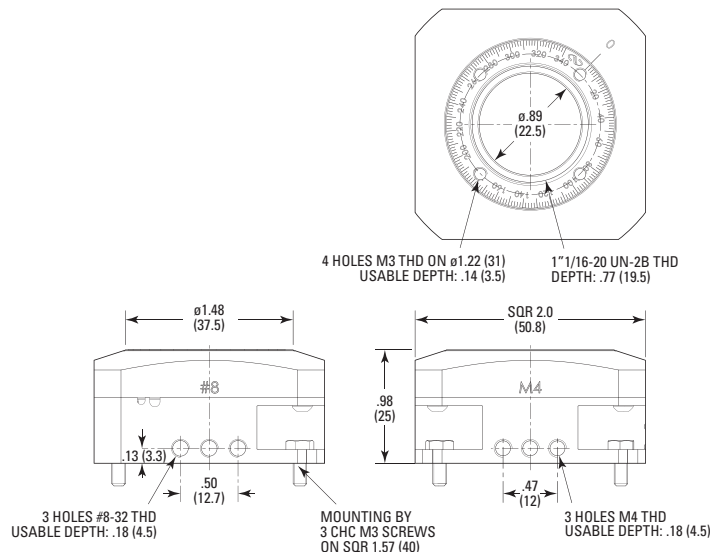

# Agilis™ CONEX-AG-GON-xP goniometric cradles



## Specifications

Model	CONEX-AG-GON-LP	CONEX-AG-GON-UP
Travel Range (°)	±5.5 °	±7.5
Resolution (°)	0.00009	0.00013
Minimum Incremental Motion (°)	0.00025	0.00032
Uni-directional Repeatability, Guaranteed (°)	0.0005	0.00064
Maximum Speed (°/s)	0.33	0.45
Normal Load Capacity (N)	3.5	3.5

The CONEX-AG-GON-LP and CONEX-AG-GON-UP are high precision piezo goniometer cradles with direct encoder feedback and integrated closed-loop CONEX motor controllers. The highly compact Agilis Goniometer cradles can be stacked to provide a high-precision open-frame motorized tip-tilt platform. Compact construction with integrated pre-configured CONEX controller, means quick connectivity and intuitive programmable operation.

Agilis Goniometer cradles are ideal for systems integration, offering compact construction, pre-configured CONEX Controller, and robust repeatable piezo performance.

For vacuum or high-class clean room applications, contact Newport.

## CONEX-AG-GON-LP

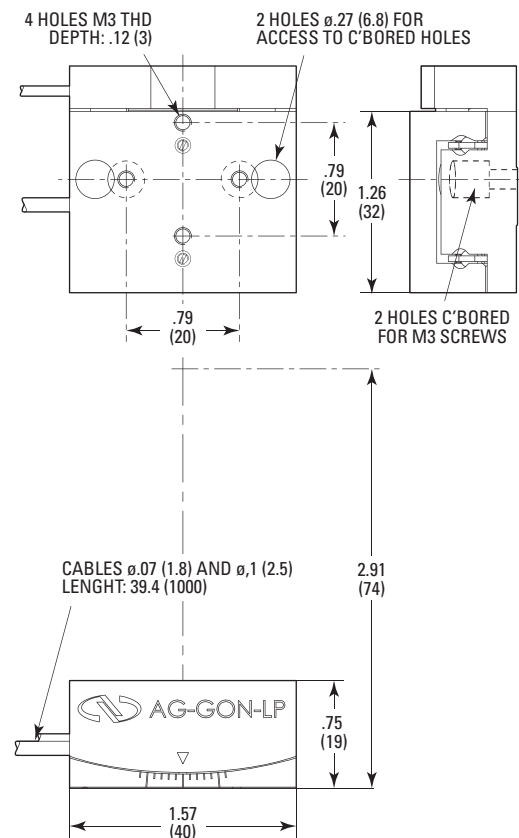
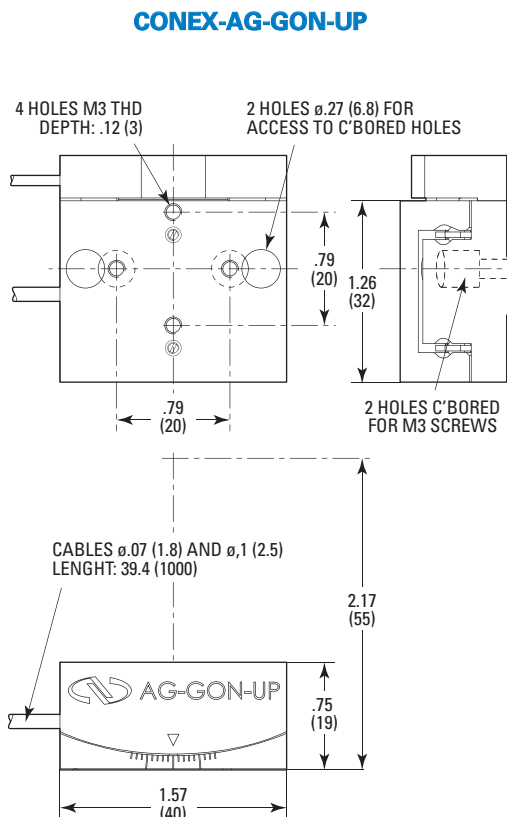

## Agilis™ motion controllers



The Agilis series of open loop positioners are controlled with compact Agilis controllers. Agilis controllers are offered with either two-axis (AG-UC2) or eight-axis control (AG-UC8).

The AG-UC2 has been designed with two rows of push buttons, for convenient manual control of Agilis positioners. The AG-UC2 also offers a full command set, remote control over USB and LabVIEW drivers. Compatible with the NSTRUCt communication server, Agilis Controllers offer fast, robust, and reliable communication.

The Agilis AG-UC8 controller provides USB computer control of up to 8 Agilis positioners. The AG-UC8 uses the same ASCII-commands, DLL and LabVIEW drivers as the AG-UC2. For convenience, an LED indicates the current controller status. Two holes in the controller allow stacking of several controllers and attachment to optical tables for easy integration.

For OEM applications, an 8-channel controller (two channels active at a time) is available with RS-232, RS-485 or USB interface on a 115 x 89 mm PCB. Upon request, the number of drive channels can be increased to 16, 24, 32, etc.



AG-UC8 8-channel controller  
with USB.

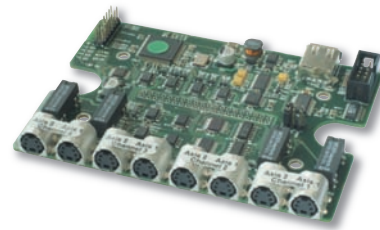

AG-UC8PC 8-channel PC-board controller  
with RS-232, RS-485 and USB.

## Custom motion and OEM applications

Newport offers special environmental preparation, testing and modification to standard products. If you have an Agilis application that requires special preparation, testing or systems integration, contact us today.

## Agilis™ compliance and compatibility



The Agilis series of products have been developed with environmentally conscious materials and are in full compliance to the directive of the restriction of the use of certain hazardous substances in electrical equipment.



NSTRUCt is a powerful communications server designed to provide a single non-interfering communications layer for USB interfaced instrumentation. The NSTRUCt environment is fully compatible with LabVIEW, and also provides an applications library that is continually expanding and being updated.

## Ordering Information

### Positioners

Model	Description
AG-LS25	Agilis Linear Stage, 12 mm travel
AG-LS25V6	Agilis Linear Stage, 12 mm travel, Vacuum Compatible
AG-LS25-27	Agilis Linear Stage, 27 mm travel
CONEX-AG-LS25-27P	Agilis Linear Stage, Integrated Encoder with Closed-Loop Operation, 27 mm Travel
AG-M050L	Agilis Mirror Mount, Integrated Limit Switches, 0.5" Optics
AG-M050LV6	Agilis Mirror Mount, Vacuum Compatible, Integrated Limit Switches, 0.5" Optics
AG-M050N	Agilis Mirror Mount, Limit Switches, 0.5" Optics
AG-M050NV6	Agilis Mirror Mount, Vacuum Compatible, 0.5" Optics
AG-M100L	Agilis Mirror Mount, Integrated Limit Switches, 1" Optics
AG-M100LV6	Agilis Mirror Mount, Vacuum Compatible, Integrated Limit Switches, 1.0" Optics
AG-M100N	Agilis Mirror Mount, 1" Optics
AG-M100NV6	Agilis Mirror Mount, Vacuum Compatible, 1" Optics
CONEX-AG-M100D	Agilis Mirror Mount, Integrated Encoder with Closed-Loop Operation, 1" Optics
AG-PR100	Agilis Rotation Stage
CONEX-AG-PR100P	Agilis Rotation Stage, Integrated Encoder with Closed-Loop Operation
CONEX-AG-GON-LP	Goniometer with Direct Encoder Feedback and Integrated Controller
CONEX-AG-GON-UP	Goniometer with Direct Encoder Feedback and Integrated Controller

### Controllers

Model	Description
AG-UC 2	Two-Axis Controller, USB Interface
AG-UC 8	Eight-Axis Controller, USB Interface
AG-UC8PC	8 Axis OEM Agilis Piezo Controller, USB/RS232/RS485 Interfaces

### Accessories

Model	Description
AG-MD4-1.5	Extension cable, 1.5 m, 4-wire mini-DIN connector
B-2B (M-B-2B)	Adaptor plate for optical tables
M-B-1.25	Adaptor plate for 40 x 40 mm stages
M-B-2C	Adaptor plate for optical tables
PRA-05	Adapter for 0.5" diameter waveplates
RSA-1TI	Solid Insert
USB-CH	Universal USB power supply, includes clips for US, EU, UK and Australia and 2-m USB cable
339233	Right angle bracket for AG-LS25

[www.newport.com](http://www.newport.com)



**Newport Corporation, Global Headquarters**  
1791 Deere Avenue, Irvine, CA 92606, USA

[www.newport.com](http://www.newport.com)

**PHONE:** 1-800-222-6440 1-949-863-3144 **FAX:** 1-949-253-1680 **EMAIL:** [sales@newport.com](mailto:sales@newport.com)

Complete listings for all global office locations are available online at [www.newport.com/contact](http://www.newport.com/contact)

	PHONE	EMAIL		PHONE	EMAIL
Belgium	+32-(0)0800-11 257	<a href="mailto:belgium@newport.com">belgium@newport.com</a>	Irvine, CA, USA	+1-800-222-6440	<a href="mailto:sales@newport.com">sales@newport.com</a>
China	+86-10-6267-0065	<a href="mailto:china@newport.com">china@newport.com</a>	Netherlands	+31-(0)30 6592111	<a href="mailto:netherlands@newport.com">netherlands@newport.com</a>
France	+33-(0)1-60-91-68-68	<a href="mailto:france@newport.com">france@newport.com</a>	United Kingdom	+44-1235-432-710	<a href="mailto:uk@newport.com">uk@newport.com</a>
Japan	+81-3-3794-5511	<a href="mailto:spectra-physics@splasers.co.jp">spectra-physics@splasers.co.jp</a>	Germany / Austria / Switzerland	+49-(0)6151-708-0	<a href="mailto:germany@newport.com">germany@newport.com</a>
Taiwan	+886 -(0)2-2508-4977	<a href="mailto:sales@newport.com.tw">sales@newport.com.tw</a>			